



R410A

Commercial Air Conditioners

# Service Manual



## Super X Series VRF

- |                       |                       |
|-----------------------|-----------------------|
| <b>38VF008H119016</b> | <b>38VF020H119016</b> |
| <b>38VF010H119016</b> | <b>38VF022H119016</b> |
| <b>38VF012H119016</b> | <b>38VF024H119016</b> |
| <b>38VF014H119016</b> | <b>38VF026H119016</b> |
| <b>38VF016H119016</b> | <b>38VF028H119016</b> |
| <b>38VF018H119016</b> | <b>38VF030H119016</b> |
|                       | <b>38VF032H119016</b> |

# CONTENTS

Part 1 General Information.....	3
Part 2 Component Layout and Refrigerant Circuits .....	11
Part 3 Control .....	33
Part 4 Field Settings.....	49
Part 5 Electrical Components and Wiring Diagrams .....	55
Part 6 Diagnosis and Troubleshooting.....	69



# Part 1

## General Information

1 Indoor and Outdoor Unit Capacities.....	4
2 External Appearance .....	6
3 Outdoor Unit Combinations.....	8
4 Combination Ratio .....	9

## 1 Indoor and Outdoor Unit Capacities

### 1.1 Indoor Units

#### 1.1.1 Standard indoor units

Table 1-1.1: Standard indoor unit abbreviation codes

Abbreviation code	Type
40VZ	One-way Cassette
40VT	Two-way Cassette
40VX	Compact Four-way Cassette
40VK	Four-way Cassette
42VD*3016	Medium Static Pressure Duct

Abbreviation code	Type
42VD*1016	High Static Pressure Duct
42VH	Wall-mounted
42VF	Ceiling & Floor
42VS	Floor Standing
42VC	Console

Table 1-1.2: Standard indoor unit capacity range

Capacity		Capacity index	40VZ	40VT	40VX	40VK	42VD *3016	42VD *1016	42VH	42VF	42VS	42VC
kW	HP											
1.8	0.6	18	18	—	—	—	—	—	—	—	18	—
2.2	0.8	22	22	22	22	—	22	—	22	—	22	22
2.8	1	28	28	28	28	28	28	—	28	—	28	28
3.6	1.25	36	36	36	36	36	36	—	36	36	36	36
4.5	1.6	45	45	45	45	45	45	—	45	45	45	45
5.6	2	56	56	56	—	56	56	—	56	56	56	—
7.1	2.5	71	71	71	—	71	71	71	71	71	71	—
8.0	3	80	—	—	—	80	80	80	80	80	80	—
9.0	3.2	90	—	—	—	90	90	90	90	90	90	—
10.0	3.6	100	—	—	—	100	—	—	—	—	—	—
11.2	4	112	—	—	—	112	112	112	—	112	—	—
14.0	5	140	—	—	—	140	140	140	—	140	—	—
16.0	6	160	—	—	—	—	—	160	—	160	—	—
20.0	7	200	—	—	—	—	—	200	—	—	—	—
25.0	9	250	—	—	—	—	—	250	—	—	—	—
28.0	10	280	—	—	—	—	—	280	—	—	—	—
40.0	14	400	—	—	—	—	—	400	—	—	—	—
45.0	16	450	—	—	—	—	—	450	—	—	—	—
56.0	20	560	—	—	—	—	—	560	—	—	—	—

#### 1.1.2 Fresh air processing unit

Table 1-1.3: Fresh air processing unit capacity range

Capacity	12.5kW	14kW	20kW	25kW	28kW
Capacity index	125	140	200	250	280

### 1.2 Heat recovery ventilator

Table 1-1.4: Heat recovery ventilator capacity range

Capacity	200m <sup>3</sup> /h	300m <sup>3</sup> /h	400m <sup>3</sup> /h	500m <sup>3</sup> /h	800m <sup>3</sup> /h	1000m <sup>3</sup> /h	1500m <sup>3</sup> /h	2000m <sup>3</sup> /h
----------	----------------------	----------------------	----------------------	----------------------	----------------------	-----------------------	-----------------------	-----------------------

**1.3 Outdoor Units**
*Table 1-1.5: Outdoor unit capacity range*

Capacity	Model Name	Combination Type
8HP	38VF008H119016	/
10HP	38VF010H119016	/
12HP	38VF012H119016	/
14HP	38VF014H119016	/
16HP	38VF016H119016	/
18HP	38VF018H119016	/
20HP	38VF020H119016	/
22HP	38VF022H119016	/
24HP	38VF024H119016	/
26HP	38VF026H119016	/
28HP	38VF028H119016	/
30HP	38VF030H119016	/
32HP	38VF032H119016	/
34HP	38VF034H119016	12HP+22HP
36HP	38VF036H119016	14HP+22HP
38HP	38VF038H119016	16HP+22HP
40HP	38VF040H119016	12HP+28HP
42HP	38VF042H119016	20HP+22HP
44HP	38VF044H119016	22HP+22HP
46HP	38VF046H119016	22HP+24HP
48HP	38VF048H119016	22HP+26HP
50HP	38VF050H119016	22HP+28HP
52HP	38VF052H119016	26HP+26HP
54HP	38VF054H119016	26HP+28HP
56HP	38VF056H119016	28HP+28HP
58HP	38VF058H119016	28HP+30HP
60HP	38VF060H119016	28HP+32HP
62HP	38VF062H119016	30HP+32HP
64HP	38VF064H119016	32HP+32HP
66HP	38VF066H119016	12HP+22HP+32HP
68HP	38VF068H119016	14HP+22HP+32HP
70HP	38VF070H119016	16HP+22HP+32HP
72HP	38VF072H119016	12HP+28HP+32HP
74HP	38VF074H119016	20HP+22HP+32HP
76HP	38VF076H119016	22HP+22HP+32HP
78HP	38VF078H119016	22HP+24HP+32HP
80HP	38VF080H119016	22HP+26HP+32HP
82HP	38VF082H119016	22HP+28HP+32HP
84HP	38VF084H119016	26HP+26HP+32HP
86HP	38VF086H119016	26HP+28HP+32HP
88HP	38VF088H119016	28HP+28HP+32HP
90HP	38VF090H119016	28HP+30HP+32HP
92HP	38VF092H119016	28HP+32HP+32HP
94HP	38VF094H119016	30HP+32HP+32HP
96HP	38VF096H119016	32HP+32HP+32HP

**Notes:**









- The combinations of units shown in the table are factory-recommended. Other combinations of units are also possible.

## 2 External Appearance

### 2.1 Indoor Units

#### 2.1.1 Standard indoor units

Table 1-2.1: Standard indoor unit appearance

One-way Cassette 40VZ 	Two-way Cassette 40VT 
Compact Four-way Cassette 40VX 	Four-way Cassette 40VK 
Medium Static Pressure Duct 42VD*3016 	High Static Pressure Duct 42VD*1016 
Wall-mounted 42VH 	Ceiling & Floor 42VF 
Floor Standing 42VS 	Console 42VC 

#### 2.1.2 Fresh air processing unit

Table 1-2.2: Fresh air processing unit appearance





Fresh Air Processing Unit 
--

## 2.2 Heat Recovery Ventilator













Table 1-2.3: Heat recovery ventilator appearance

Heat Recovery Ventilator 
---

**2.3 Outdoor Units**
**2.3.1 Single units**
*Table 1-2.4: Single outdoor unit appearance*

8/10/12HP (with single fan)	14/16HP (with single fan)	18/20/22HP (with dual fans)	24/26/28/30/32HP (with dual fans)
			

**2.3.2 Combinations of units**
*Table 1-2.5: Combination outdoor unit appearance*

<p data-bbox="284 763 352 790"><b>34HP</b></p> 	<p data-bbox="738 763 839 790"><b>36/38HP</b></p> 	<p data-bbox="1235 763 1303 790"><b>40HP</b></p> 
<p data-bbox="268 1140 368 1167"><b>42/44HP</b></p> 	<p data-bbox="719 1140 858 1167"><b>46/48/50HP</b></p> 	<p data-bbox="1114 1140 1422 1167"><b>52/54/56/58/60/62/64HP</b></p> 
<p data-bbox="288 1516 357 1543"><b>66HP</b></p> 	<p data-bbox="738 1516 839 1543"><b>68/70HP</b></p> 	<p data-bbox="1235 1516 1303 1543"><b>72HP</b></p> 
<p data-bbox="268 1812 368 1839"><b>74/76HP</b></p> 	<p data-bbox="719 1812 858 1839"><b>78/80/82HP</b></p> 	<p data-bbox="1114 1812 1422 1839"><b>84/86/88/90/92/94/96HP</b></p> 



## 3 Outdoor Unit Combinations

Table 1-3.1: Outdoor unit combinations

System capacity		Number of units	Modules <sup>1</sup>													Outdoor branch joint kit <sup>2</sup>		
kW	HP		8	10	12	14	16	18	20	22	24	26	28	30	32			
25.2	8	1	•															
28.0	10	1		•														
33.5	12	1			•													
40.0	14	1				•												
45.0	16	1					•											
50.0	18	1						•										
56.0	20	1							•									
61.5	22	1								•								
67.0	24	1									•							
73.0	26	1										•						
78.5	28	1											•					
85.0	30	1												•				
90.0	32	1															•	
95.0	34	2			•					•								
101.5	36	2				•				•								
106.5	38	2					•			•								
112.0	40	2			•								•					
117.5	42	2							•	•								
123.0	44	2								••								
128.5	46	2								•	•							
134.5	48	2								•		•						
140.0	50	2								•			•					
146.0	52	2										••						
151.5	54	2										•	•					
157.0	56	2											••					
163.5	58	2											•	•				
168.5	60	2											•				•	
175.0	62	2												•			•	
180.0	64	2															••	
185.0	66	3			•					•								•
191.5	68	3				•				•								•
196.5	70	3					•			•								•
202.0	72	3			•								•					•
207.5	74	3							•	•								•
213.0	76	3								••								•
218.5	78	3								•	•							•
224.5	80	3								•		•						•
230.0	82	3								•			•					•
236.0	84	3										••						•
241.5	86	3										•	•					•
247.0	88	3											••					•
253.5	90	3											•	•				•
258.5	92	3											•				••	
265.0	94	3												•			••	
270.0	96	3															•••	

Notes:

1. The combinations of units shown in the table are factory-recommended. Other combinations of units are also possible.
2. For systems with two or more outdoor units, outdoor branch joints (sold separately) are required.

## 4 Combination Ratio

$$\text{Combination ratio} = \frac{\text{Sum of capacity indexes of the indoor units}}{\text{Capacity index of the outdoor units}}$$

Table 1-5.1: Indoor and outdoor unit combination ratio limitations

Type	Minimum combination ratio	Maximum combination ratio		
		Standard indoor units only	Fresh air processing units only	Fresh air processing units and standard indoor units together
V6 Series outdoor units	50%	130%	100%	100% <sup>1</sup>

Notes:

- When fresh air processing units are installed together with standard indoor units, the total capacity of the fresh air processing units must not exceed 30% of the total capacity of the outdoor units and the combination ratio must not exceed 100%.

Table 1-5.2: Combinations of Indoor and outdoor units

Outdoor unit capacity			Sum of capacity indexes of connected indoor units (standard indoor units only)	Sum of capacity indexes of connected indoor units (fresh air processing units and standard indoor units together)	Maximum number of connected indoor units
kW	HP	Capacity index			
25.2	8	252	126 to 327.6	126 to 252	13
28.0	10	280	140 to 364	140 to 280	16
33.5	12	335	167.5 to 435.5	167.5 to 335	20
40.0	14	400	200 to 520	200 to 400	23
45.0	16	450	225 to 585	225 to 450	26
50.0	18	500	250 to 650	250 to 500	29
56.0	20	560	280 to 728	280 to 560	33
61.5	22	615	307.5 to 799.5	307.5 to 615	36
67.0	24	670	335 to 871	335 to 670	39
73.0	26	730	365 to 949	365 to 730	43
78.5	28	785	392.5 to 1020.5	392.5 to 785	46
85.0	30	850	425 to 1105	425 to 850	50
90.0	32	900	450 to 1170	450 to 900	53
95.0	34	950	475 to 1235	475 to 950	56
101.5	36	1015	507.5 to 1319.5	507.5 to 1015	59
106.5	38	1065	532.5 to 1384.5	532.5 to 1065	63
112.0	40	1120	560 to 1456	560 to 1120	64
117.5	42	1175	587.5 to 1527.5	587.5 to 1175	
123.0	44	1230	615 to 1599	615 to 1230	
128.5	46	1285	642.5 to 1670.5	642.5 to 1285	
134.5	48	1345	672.5 to 1748.5	672.5 to 1345	
140.0	50	1400	700 to 1820	700 to 1400	
146.0	52	1460	730 to 1898	730 to 1460	
151.5	54	1515	757.5 to 1969.5	757.5 to 1515	
157.0	56	1570	785 to 2041	785 to 1570	
163.5	58	1635	817.5 to 2125.5	817.5 to 1635	
168.5	60	1685	842.5 to 2190.5	842.5 to 1685	
175.0	62	1750	875 to 2275	875 to 1750	
180.0	64	1800	900 to 2340	900 to 1800	
185.0	66	1850	925 to 2405	925 to 1850	
191.5	68	1915	957.5 to 2489.5	957.5 to 1915	
196.5	70	1965	982.5 to 2554.5	982.5 to 1965	
202.0	72	2020	1010 to 2626	1010 to 2020	
207.5	74	2075	1037.5 to 2697.5	1037.5 to 2075	
213.0	76	2130	1065 to 2769	1065 to 2130	
218.5	78	2185	1092.5 to 2840.5	1092.5 to 2185	
224.5	80	2245	1122.5 to 2918.5	1122.5 to 2245	
230.0	82	2300	1150 to 2990	1150 to 2300	
236.0	84	2360	1180 to 3068	1180 to 2360	
241.5	86	2415	1207.5 to 3139.5	1207.5 to 2415	
247.0	88	2470	1235 to 3211	1235 to 2470	
253.5	90	2535	1267.5 to 3295.5	1267.5 to 2535	
258.5	92	2585	1292.5 to 3360.5	1292.5 to 2585	
265.0	94	2650	1325 to 3445	1325 to 2650	
270.0	96	2700	1350 to 3510	1350 to 2700	



# Part 2

# Component Layout and Refrigerant Circuits

1	Layout of Functional Components .....	12
2	Piping Diagrams .....	16
3	Refrigerant Flow Diagrams .....	22

## 1 Layout of Functional Components

8/10/12HP

Figure 2-1.1: 8/10/12 layout of functional components

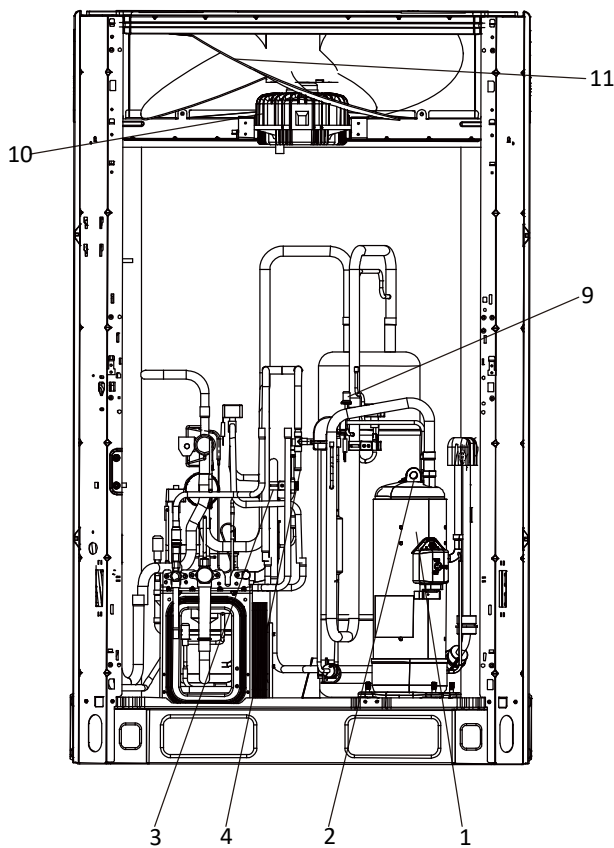
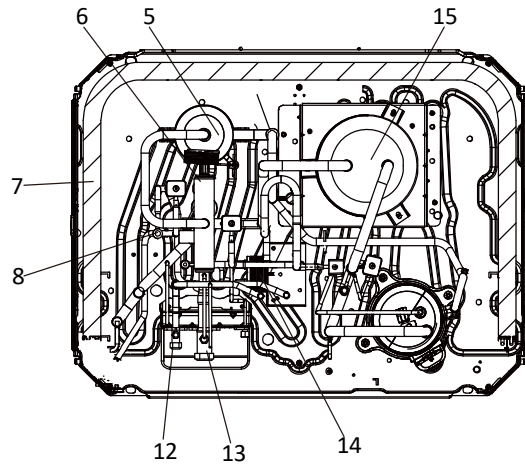

Legend	
No.	Parts name
1	Compressor
2	Discharge temperature switch
3	High pressure switch
4	High pressure sensor
5	Oil separator
6	Four-way valve
7	Heat exchanger
8	Electronic expansion valve (EXV)
9	Low pressure switch
10	Fan motor
11	Fan
12	Stop valve (liquid side)
13	Stop valve (gas side)
14	Plate heat exchanger

## 14/16HP

Figure 2-1.2: 14/16 layout of functional components

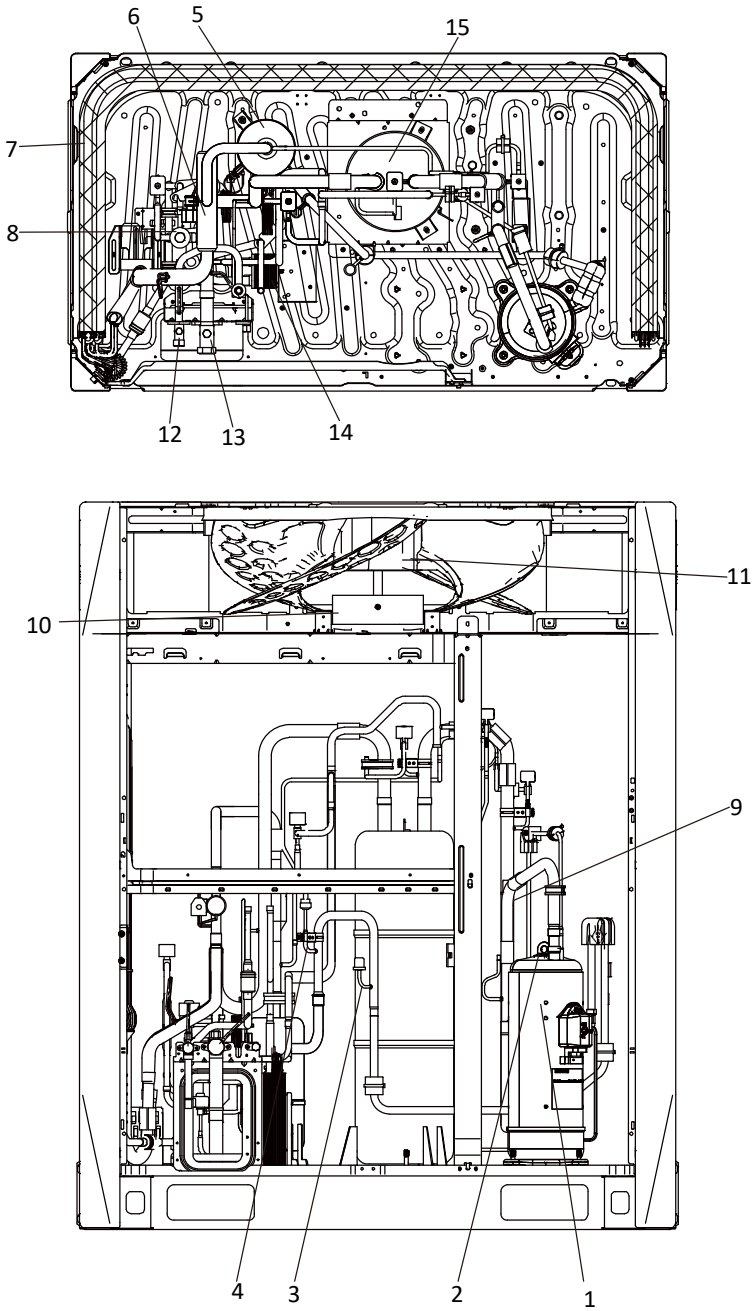

Legend	
No.	Parts name
1	Compressor
2	Discharge temperature switch
3	High pressure switch
4	High pressure sensor
5	Oil separator
6	Four-way valve
7	Heat exchanger
8	Electronic expansion valve (EXV)
9	Low pressure switch
10	Fan motor
11	Fan
12	Stop valve (liquid side)
13	Stop valve (gas side)
14	Plate heat exchanger
15	Accumulator

# Super X VRF 50/60Hz



## 18/20/22HP

Figure 2-1.3: 18/20/22 layout of functional components

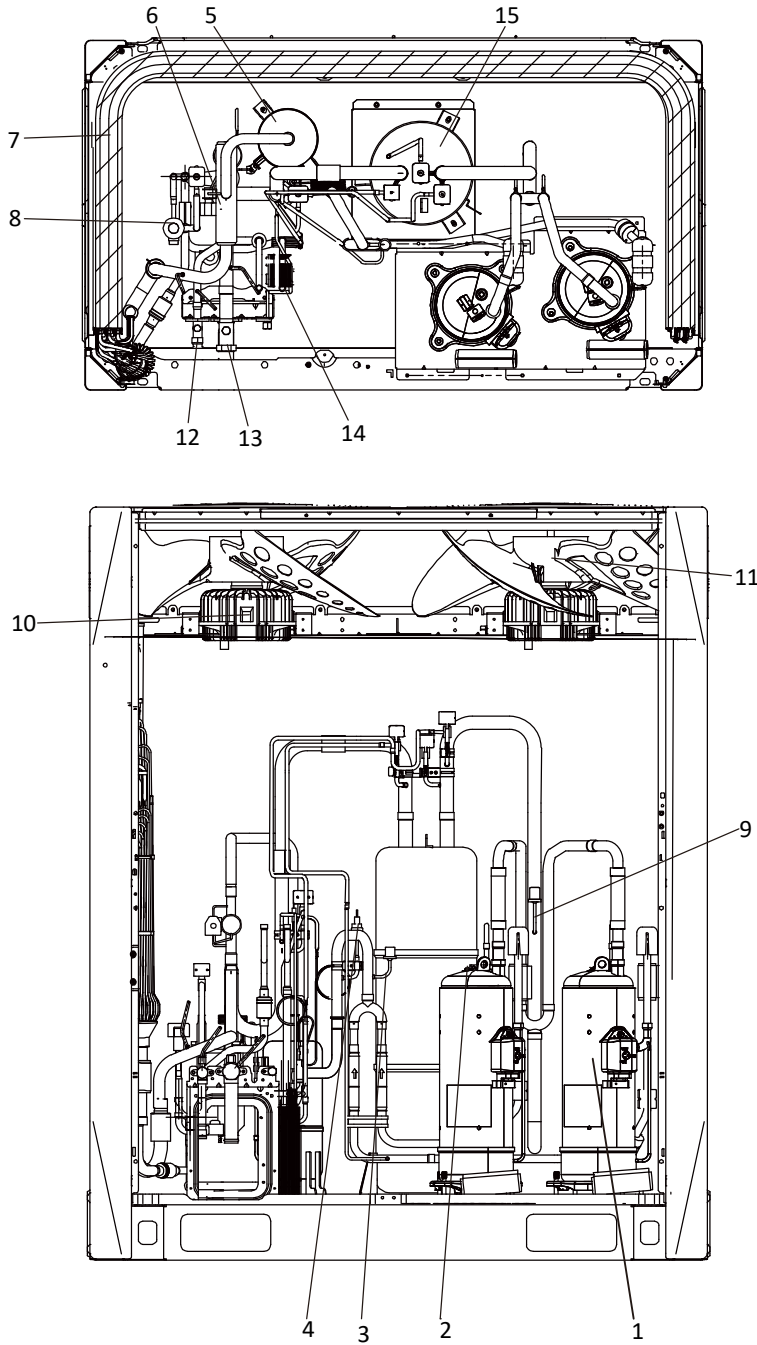

Legend	
No.	Parts name
1	Compressor
2	Discharge temperature switch
3	High pressure switch
4	High pressure sensor
5	Oil separator
6	Four-way valve
7	Heat exchanger
8	Electronic expansion valve (EXV)
9	Low pressure switch
10	Fan motor
11	Fan
12	Stop valve (liquid side)
13	Stop valve (gas side)
14	Plate heat exchanger
15	Accumulator

## 24/26/28/30/32HP

Figure 2-1.4: 24/26/28/30/32 layout of functional components

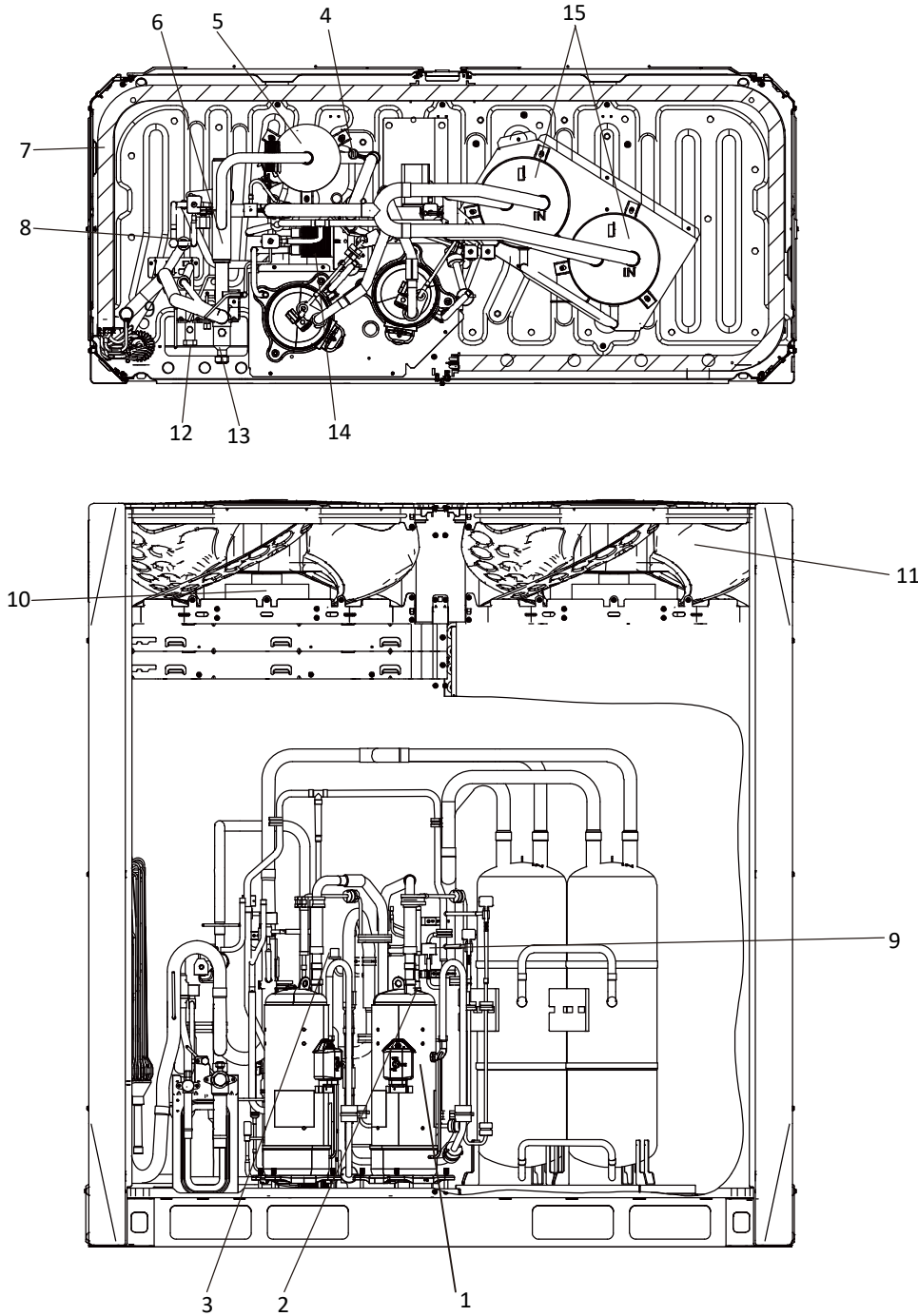

Legend	
No.	Parts name
1	Compressor
2	Discharge temperature switch
3	High pressure switch
4	High pressure sensor
5	Oil separator
6	Four-way valve
7	Heat exchanger
8	Electronic expansion valve (EXV)
9	Low pressure switch
10	Fan motor
11	Fan
12	Stop valve (liquid side)
13	Stop valve (gas side)
14	Plate heat exchanger
15	Accumulator



## 2 Piping Diagrams

8/10/12HP

Figure 2-2.1: 8/10/12HP piping diagram

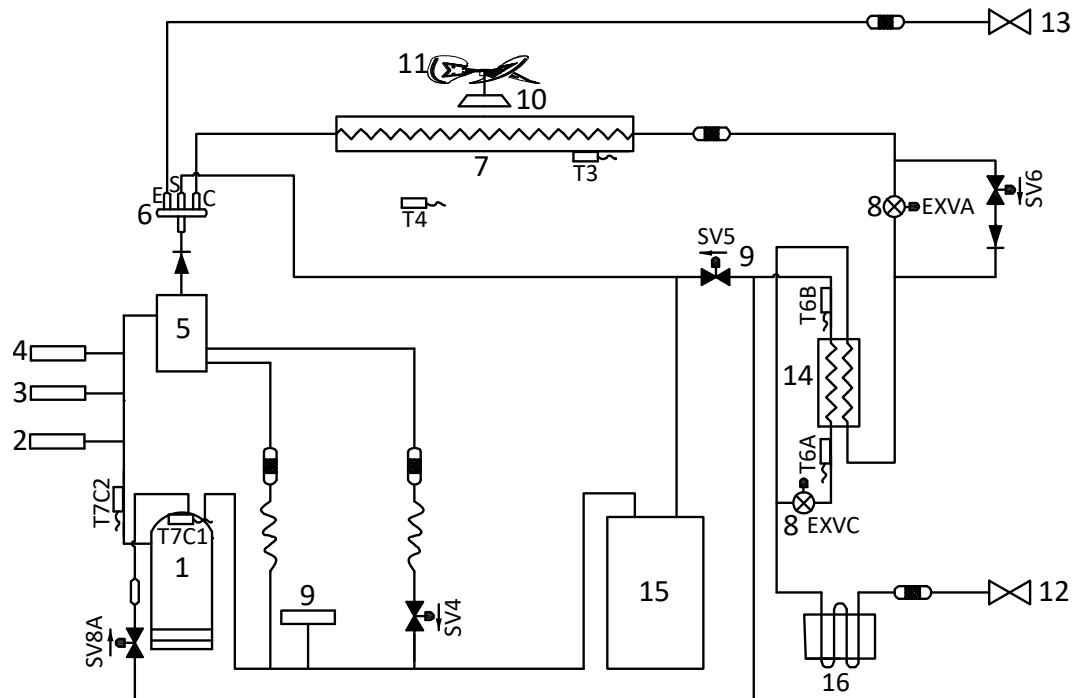

Legend			
No.	Parts name	No.	Parts name
1	Compressor	14	Plate heat exchanger
2	Discharge temperature switch	15	Accumulator
3	High pressure switch	16	Heat exchanger cooling electric control box
4	High pressure sensor	T3	Heat exchanger temperature sensor
5	Oil separator	T4	Outdoor ambient temperature sensor
6	Four-way valve	T6A	Plate heat exchanger inlet temperature sensor
7	Heat exchanger	T6B	Plate heat exchanger outlet temperature sensor
8	Electronic expansion valve (EXV)	T7C1	Compressor A discharge temperature sensor
9	Low pressure switch	T7C2	Compressor B discharge temperature sensor
10	Fan motor	SV4	Oil return valve
11	Fan	SV5	Fast defrosting (in heating) and unloading (in cooling) valve
12	Stop valve (liquid side)	SV6	Refrigerant bypass EXV valve
13	Stop valve (gas side)	SV8A	Compressor A vapor injection valve

**14/16HP**

Figure 2-2.2: 14/16HP piping diagram

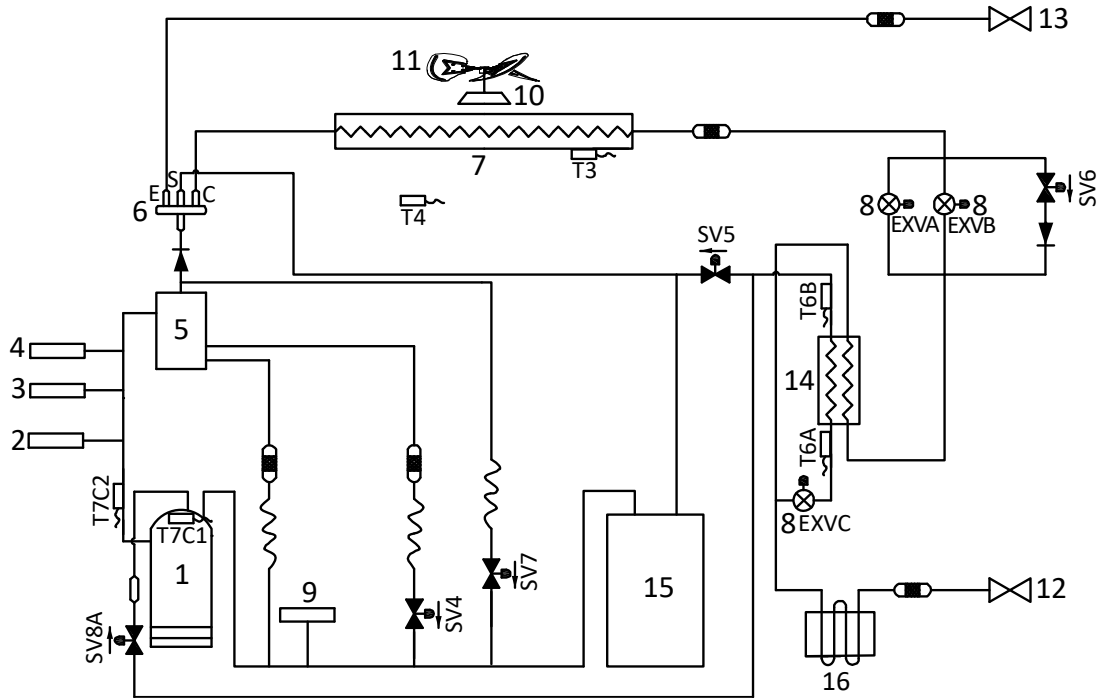

Legend		Legend	
No.	Parts name	No.	Parts name
1	Compressor	15	Accumulator
2	Discharge temperature switch	16	Heat exchanger cooling electric control box
3	High pressure switch	T3	Heat exchanger temperature sensor
4	High pressure sensor	T4	Outdoor ambient temperature sensor
5	Oil separator	T6A	Plate heat exchanger inlet temperature sensor
6	Four-way valve	T6B	Plate heat exchanger outlet temperature sensor
7	Heat exchanger	T7C1	Compressor A discharge temperature sensor
8	Electronic expansion valve (EXV)	T7C2	Compressor B discharge temperature sensor
9	Low pressure switch	SV4	Oil return valve
10	Fan motor	SV5	Fast defrosting (in heating) and unloading (in cooling) valve
11	Fan	SV6	Refrigerant bypass EXV valve
12	Stop valve (liquid side)	SV7	Refrigerant bypass indoor units valve
13	Stop valve (gas side)	SV8A	Compressor A vapor injection valve
14	Plate heat exchanger		

Figure 2-2.3: 18/20/22HP piping diagram

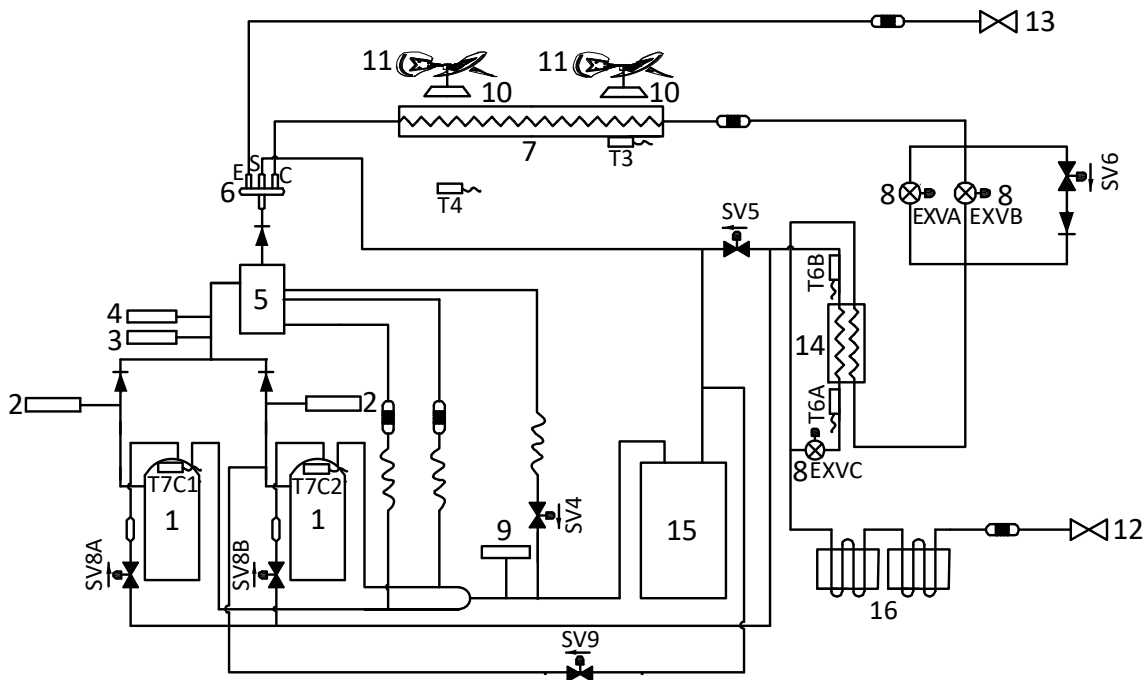

Legend		Legend	
No.	Parts name	No.	Parts name
1	Compressor	15	Accumulator
2	Discharge temperature switch	16	Heat exchanger cooling electric control box
3	High pressure switch	T3	Heat exchanger temperature sensor
4	High pressure sensor	T4	Outdoor ambient temperature sensor
5	Oil separator	T6A	Plate heat exchanger inlet temperature sensor
6	Four-way valve	T6B	Plate heat exchanger outlet temperature sensor
7	Heat exchanger	T7C1	Compressor A discharge temperature sensor
8	Electronic expansion valve (EXV)	T7C2	Compressor B discharge temperature sensor
9	Low pressure switch	SV4	Oil return valve
10	Fan motor	SV5	Fast defrosting (in heating) and unloading (in cooling) valve
11	Fan	SV6	Refrigerant bypass EXV valve
12	Stop valve (liquid side)	SV8A	Compressor A vapor injection valve
13	Stop valve (gas side)	SV8B	Compressor B vapor injection valve
14	Plate heat exchanger	SV9	Compressor B pressure balance valve

**24/26/28HP**

Figure 2-2.4: 24/26/28HP piping diagram

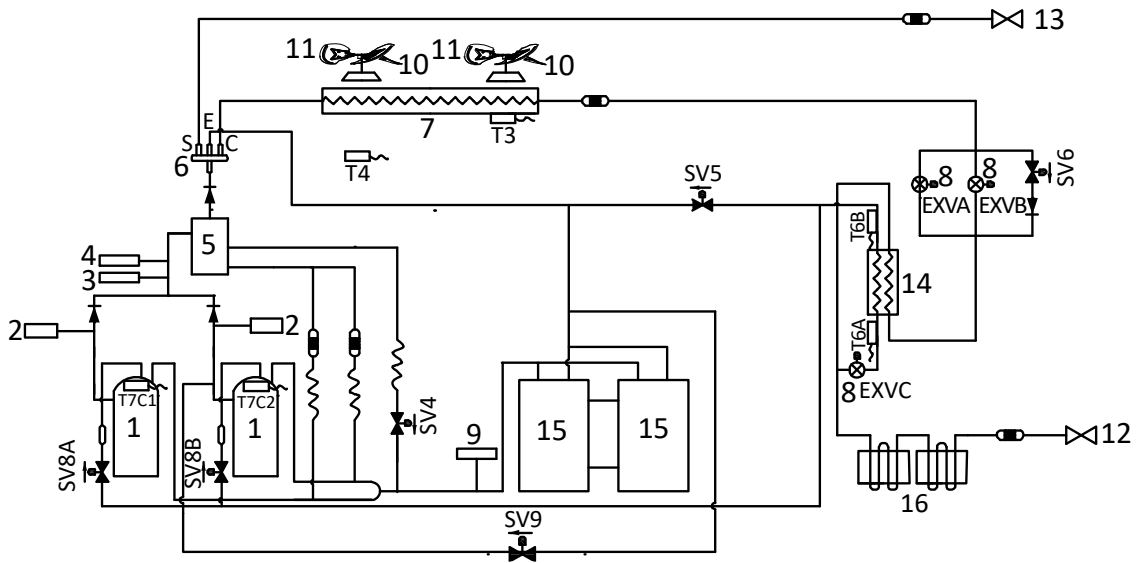

Legend		Legend	
No.	Parts name	No.	Parts name
1	Compressor	15	Accumulator
2	Discharge temperature switch	16	Heat exchanger cooling electric control box
3	High pressure switch	T3	Heat exchanger temperature sensor
4	High pressure sensor	T4	Outdoor ambient temperature sensor
5	Oil separator	T6A	Plate heat exchanger inlet temperature sensor
6	Four-way valve	T6B	Plate heat exchanger outlet temperature sensor
7	Heat exchanger	T7C1	Compressor A discharge temperature sensor
8	Electronic expansion valve (EXV)	T7C2	Compressor B discharge temperature sensor
9	Low pressure switch	SV4	Oil return valve
10	Fan motor	SV5	Fast defrosting (in heating) and unloading (in cooling) valve
11	Fan	SV6	Refrigerant bypass EXV valve
12	Stop valve (liquid side)	SV8A	Compressor A vapor injection valve
13	Stop valve (gas side)	SV8B	Compressor B vapor injection valve
14	Plate heat exchanger	SV9	Compressor B pressure balance valve

Figure 2-2.5: 30/32HP piping diagram

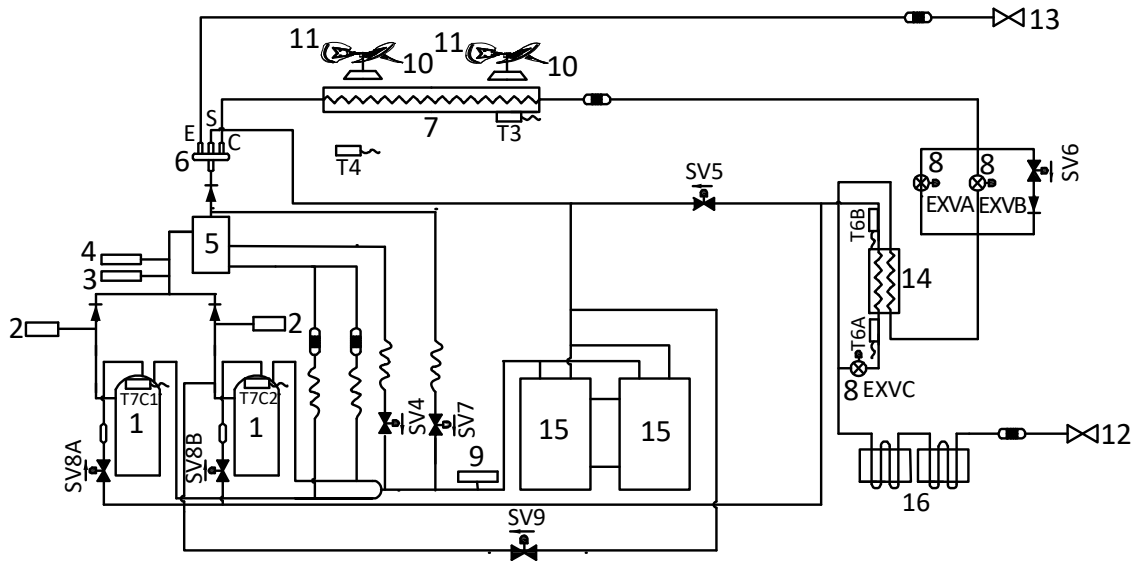

Legend		Legend	
No.	Parts name	No.	Parts name
1	Compressor	16	Heat exchanger cooling electric control box
2	Discharge temperature switch	T3	Heat exchanger temperature sensor
3	High pressure switch	T4	Outdoor ambient temperature sensor
4	High pressure sensor	T6A	Plate heat exchanger inlet temperature sensor
5	Oil separator	T6B	Plate heat exchanger outlet temperature sensor
6	Four-way valve	T7C1	Compressor A discharge temperature sensor
7	Heat exchanger	T7C2	Compressor B discharge temperature sensor
8	Electronic expansion valve (EXV)	SV4	Oil return valve
9	Low pressure switch	SV5	Fast defrosting (in heating) and unloading (in cooling) valve
10	Fan motor	SV6	Refrigerant bypass EXV valve
11	Fan	SV7	Refrigerant bypass indoor units valve
12	Stop valve (liquid side)	SV8A	Compressor A vapor injection valve
13	Stop valve (gas side)	SV8B	Compressor B vapor injection valve
14	Plate heat exchanger	SV9	Compressor B pressure balance valve
15	Accumulator		

**Key components:**

1. **Oil separator:**  
Separates oil from gas refrigerant pumped out of the compressor and quickly returns it to the compressor. Separation efficiency is up to 99%.
2. **Accumulator:**  
Stores liquid refrigerant and oil to protect compressor from liquid hammering.
3. **Electronic expansion valve (EXV):**  
Controls refrigerant flow and reduces refrigerant pressure.
4. **Four-way valve:**  
Controls refrigerant flow direction. Closed in cooling mode and open in heating mode. When closed, the heat exchanger functions as a condenser; when open, the heat exchanger functions as an evaporator.
5. **Plate heat exchanger:**  
In cooling mode, it can improve super-cooling degree and the super-cooled refrigerant can achieve better heat exchange in indoor side. In heating mode, the refrigerant comes from the plate heat exchanger going to the compressor can enhance the refrigerant enthalpy and improve the heating capacity in low ambient temperature. Refrigerant volume in plate heat exchanger is controlled according to temperature different between plate heat exchanger inlet and outlet.
6. **Solenoid valve SV4:**  
Returns oil to the compressor. Opens once the compressor has run for 200 seconds and closes 600 seconds later and then opens for 3 minutes every 20 minutes.
7. **Solenoid valve SV5:**  
Enables fast defrosting in heating mode and unloading in cooling mode. During defrosting operation, opens to shorten the refrigerant flow cycle and quicken the defrosting process. In cooling mode, SV5 opens when outdoor ambient temperature is above 40°C or compressor frequency is below 41Hz.
8. **Solenoid valve SV6:**  
Allows refrigerant to bypass the expansion valves. Opens in cooling mode when discharge temperature exceeds the limit. Closed in heating mode and standby.
9. **Solenoid valve SV7:**  
Allows refrigerant to return directly to the compressor. Opens when indoor air temperature is close to the set temperature to avoid frequent compressor on/off.
10. **Solenoid valve SV8A / SV8B:**  
Allows refrigerant from plate heat exchanger inject directly to the compressor. SV8A opens when compressor A startup and closes when compressor A stop. SV8B delays opening when compressor B startup and closes when compressor B stop.
11. **Solenoid valve SV9:**  
Balances compressor B pressure. Opens before compressor B startup and closed after compressor B running for 15 seconds. Opens after compressor B stops 10s and keep opening 60s.
12. **High and low pressure switches:**  
Regulate system pressure. When system pressure rises above the upper limit or falls below the lower limit, the high or low pressure switches turn off, stopping the compressor. After 10 minutes, the compressor restarts.

## 3 Refrigerant Flow Diagrams

### 8/10/12HP

#### Cooling operation

Figure 2-3.1: 8/10/12HP refrigerant flow during cooling operation

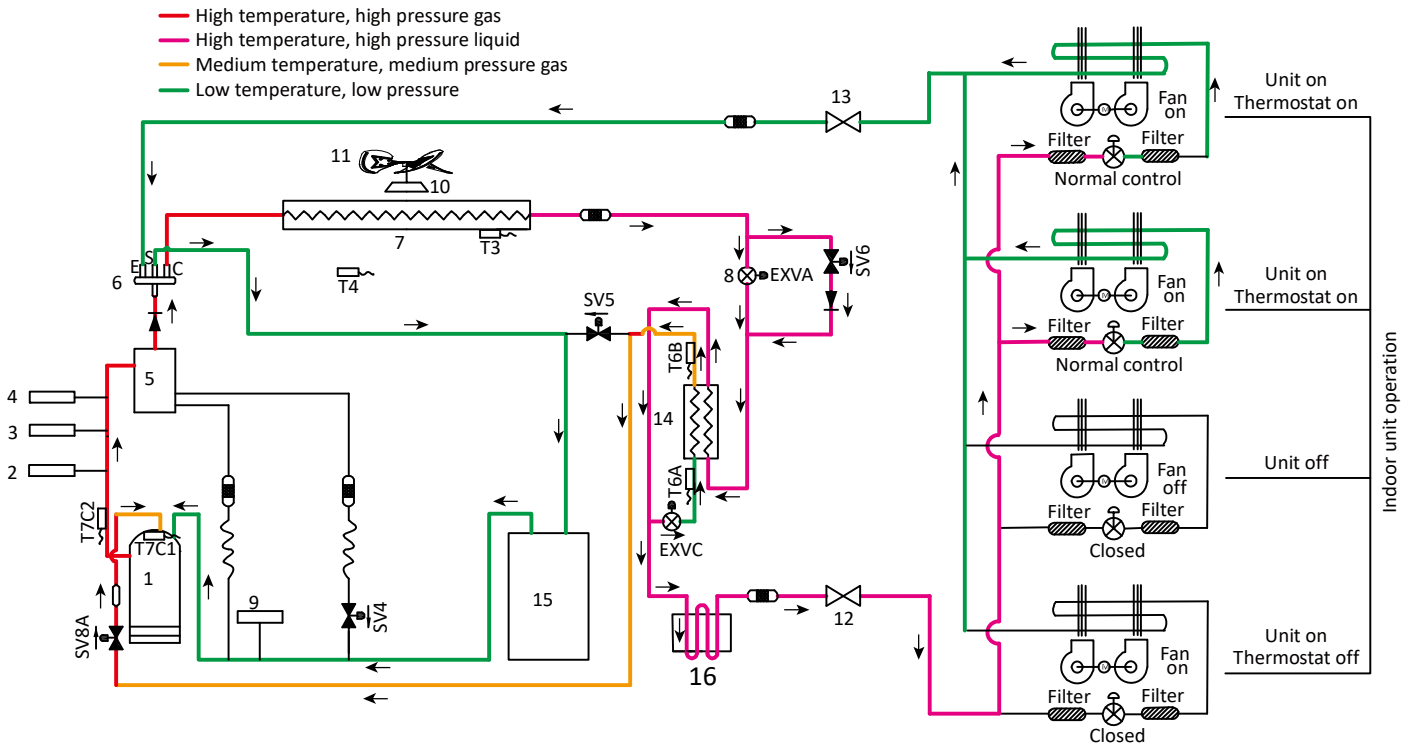

#### Oil return operation in cooling mode

Figure 2-3.2: 8/10/12HP refrigerant flow during oil return operation in cooling mode

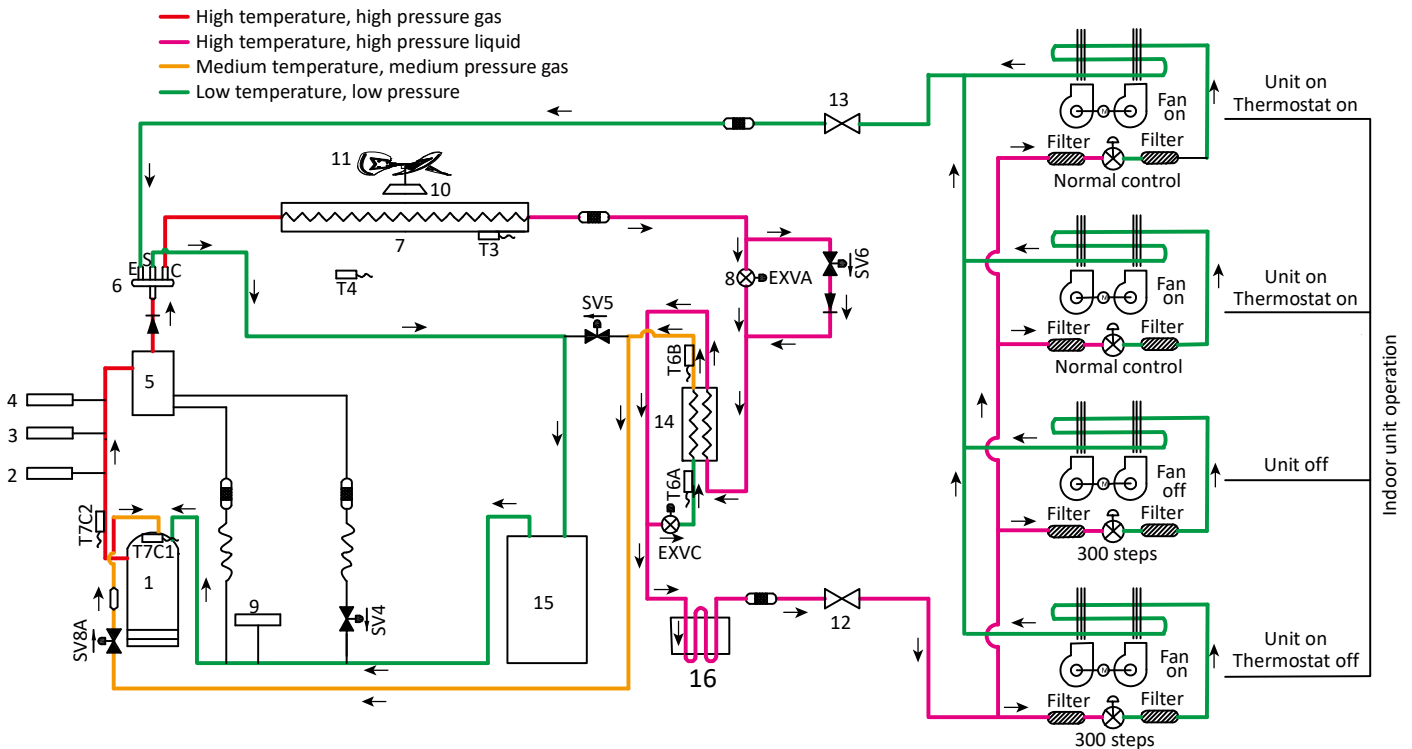

**Oil return operation in heating mode and defrosting operation**

Figure 2-3.3: 8/10/12HP refrigerant flow during oil return operation in heating mode and during defrosting operation

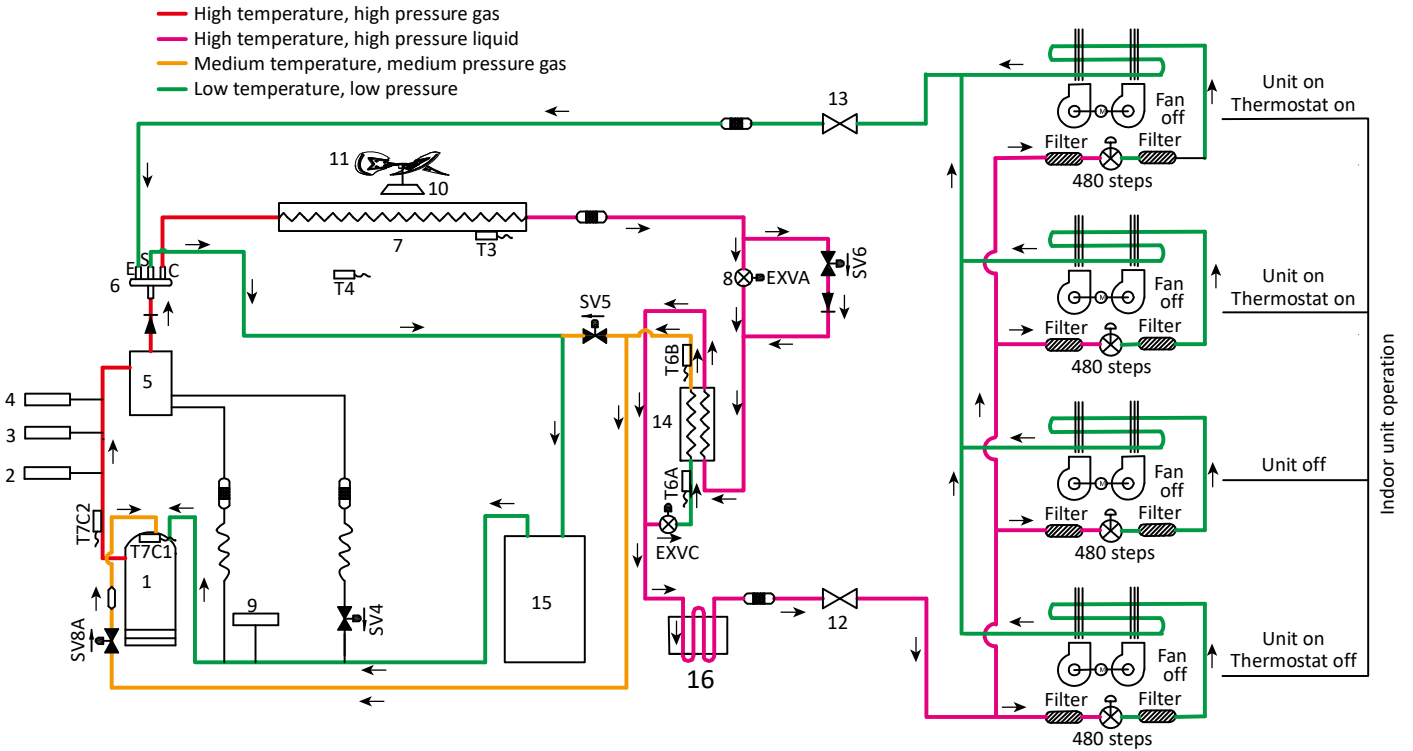

**Heating operation**

Figure 2-3.4: 8/10/12HP refrigerant flow during heating operation

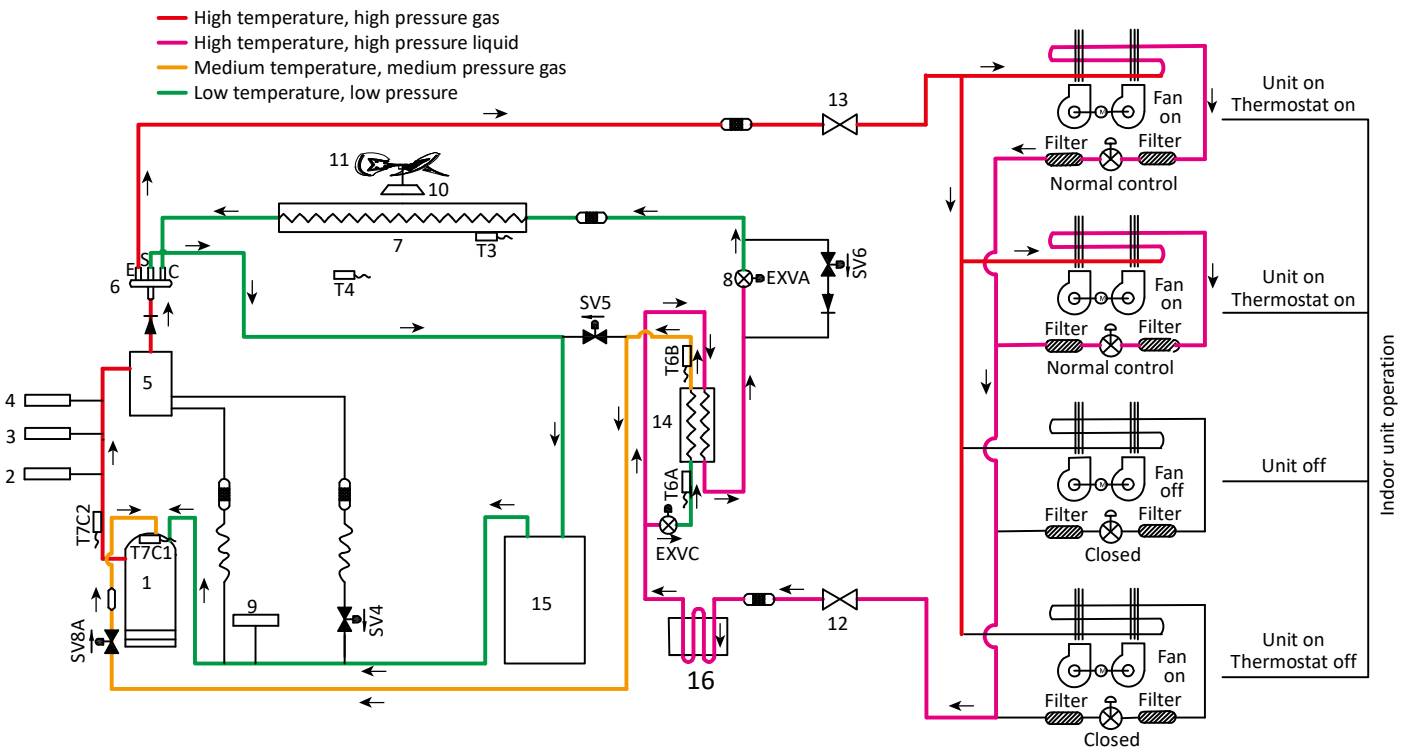



## 14/16HP

### Cooling operation

Figure 2-3.5: 14/16 refrigerant flow during cooling operation

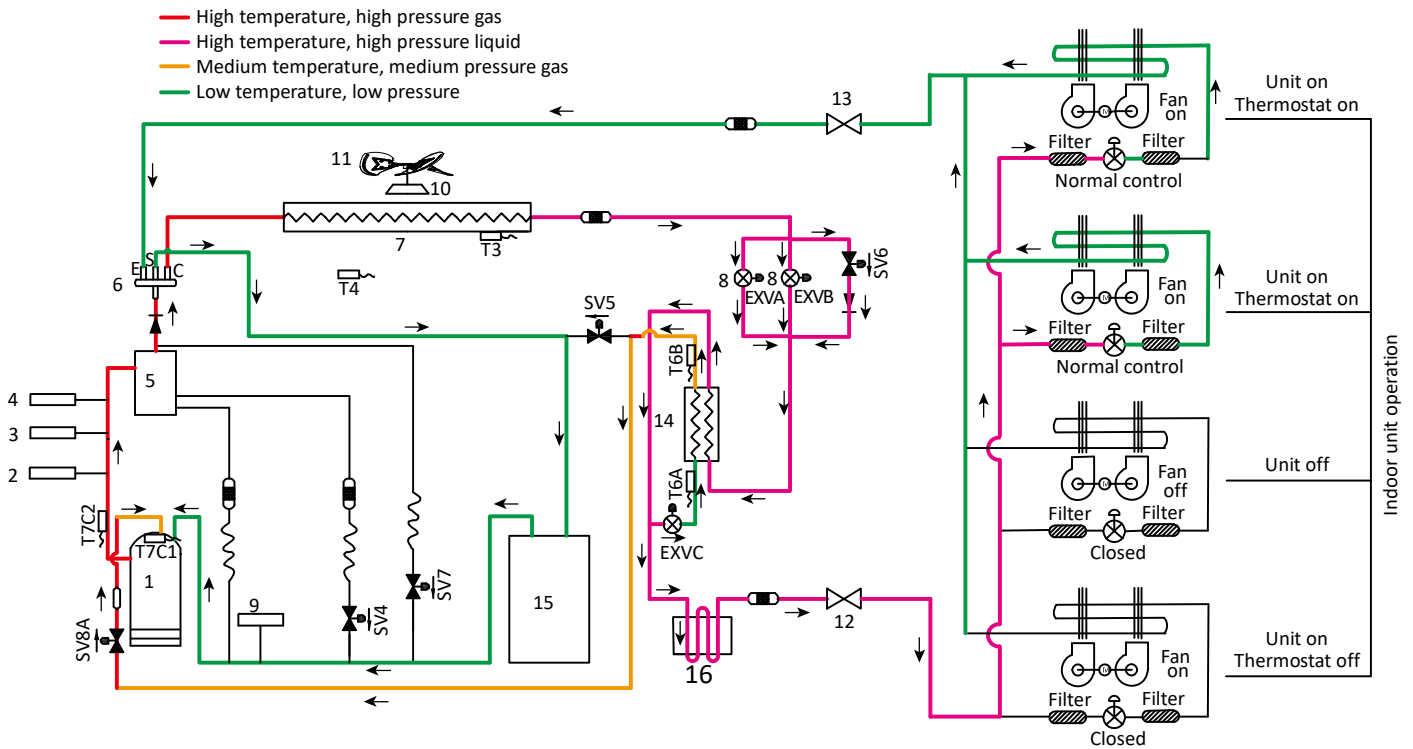

### Oil return operation in cooling mode

Figure 2-3.6: 14/16HP refrigerant flow during oil return operation in cooling mode

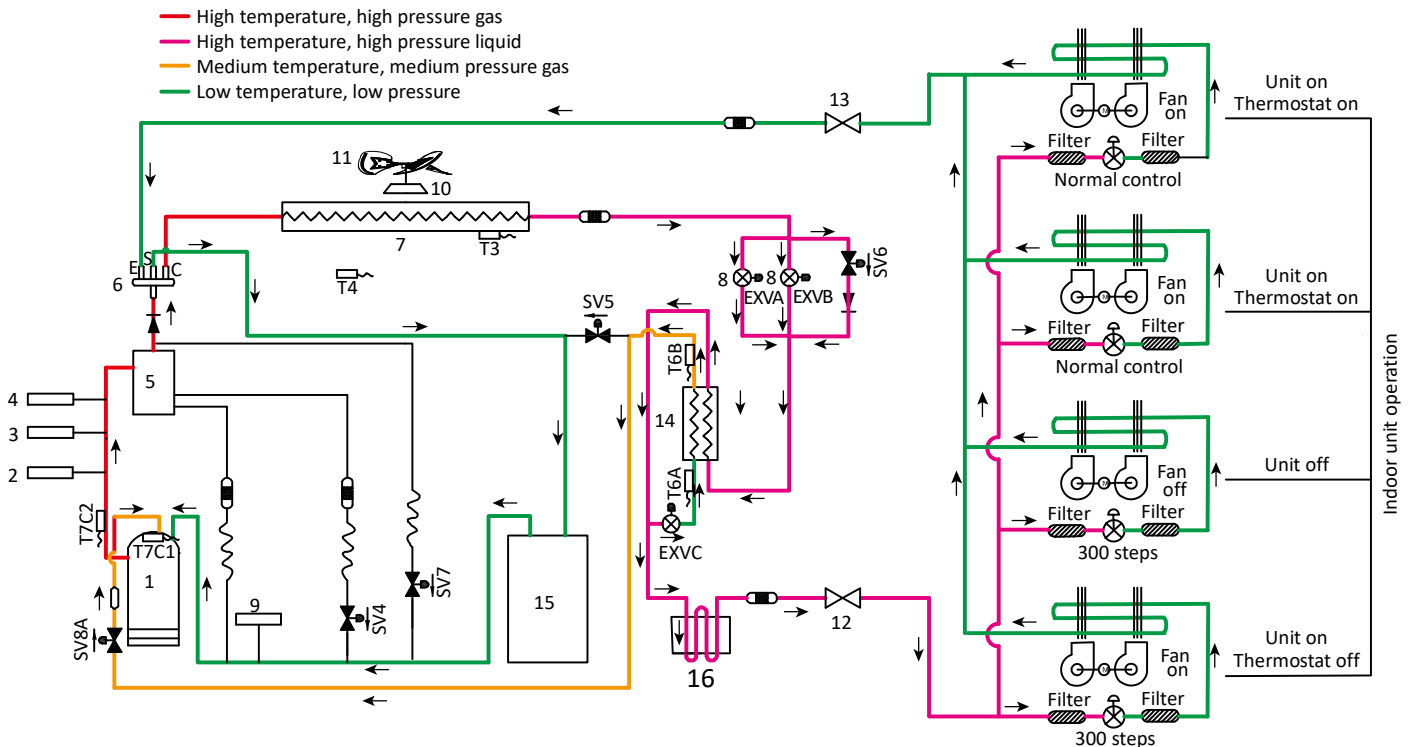

**Oil return operation in heating mode and defrosting operation**

Figure 2-3.7: 14/16HP refrigerant flow during oil return operation in heating mode and during defrosting operation

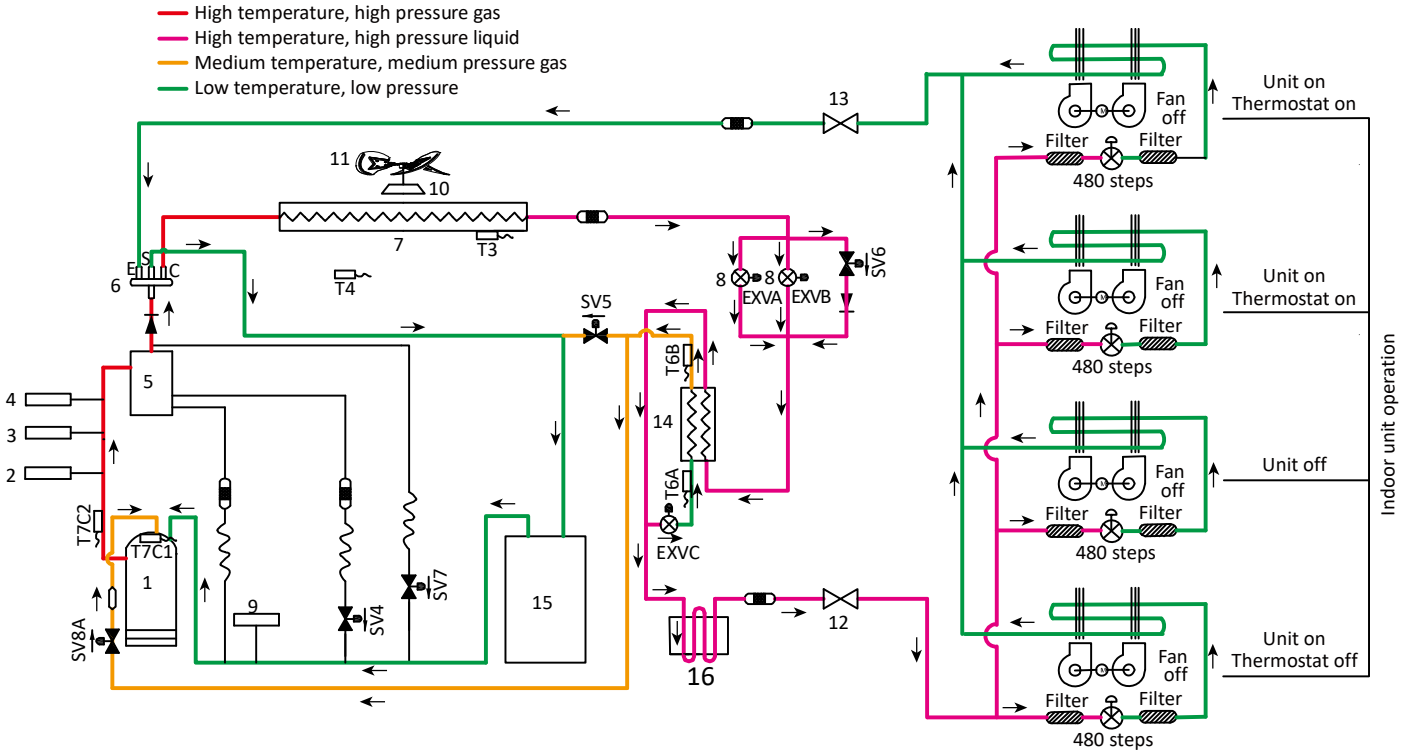

**Heating operation**

Figure 2-3.8: 14/16HP refrigerant flow during heating operation

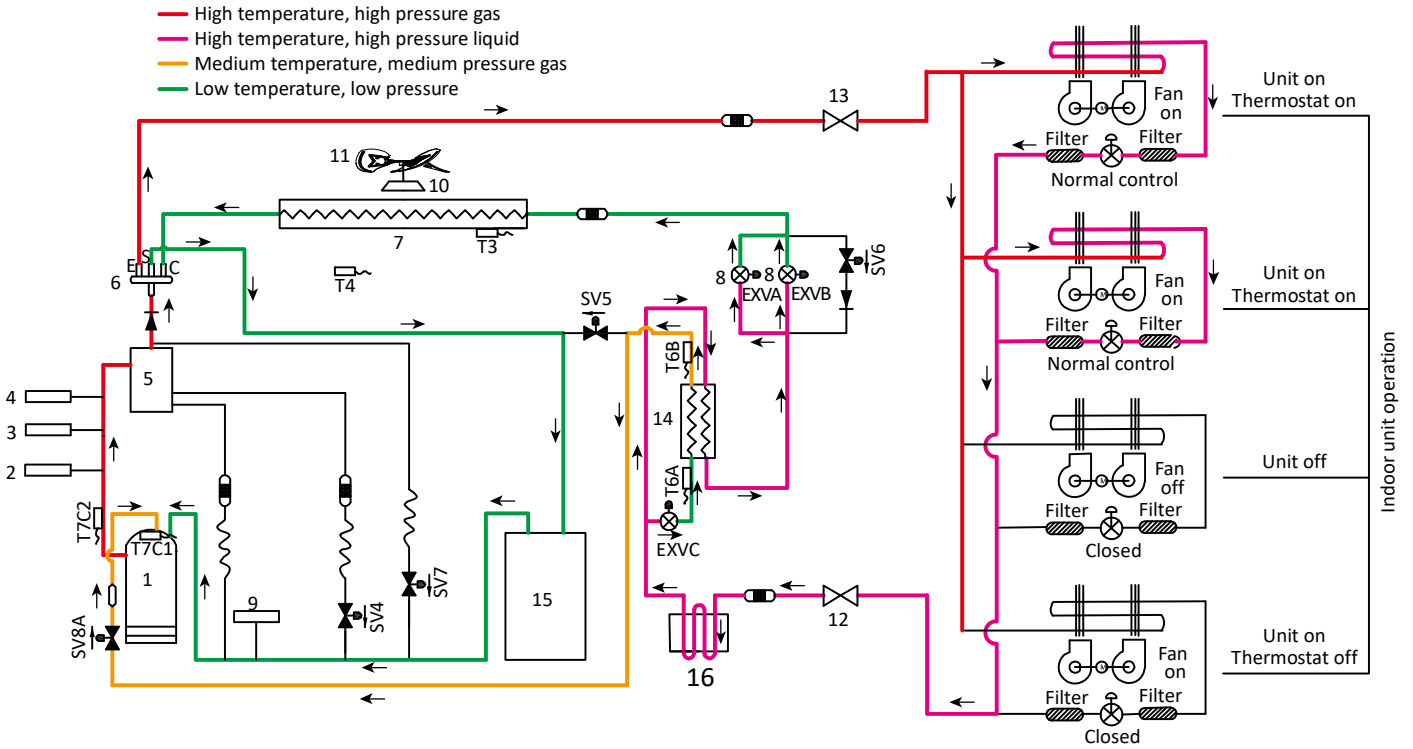

# Super X VRF 50/60Hz



18/20/22HP

## Cooling operation

Figure 2-3.9: 18/20/22 refrigerant flow during cooling operation

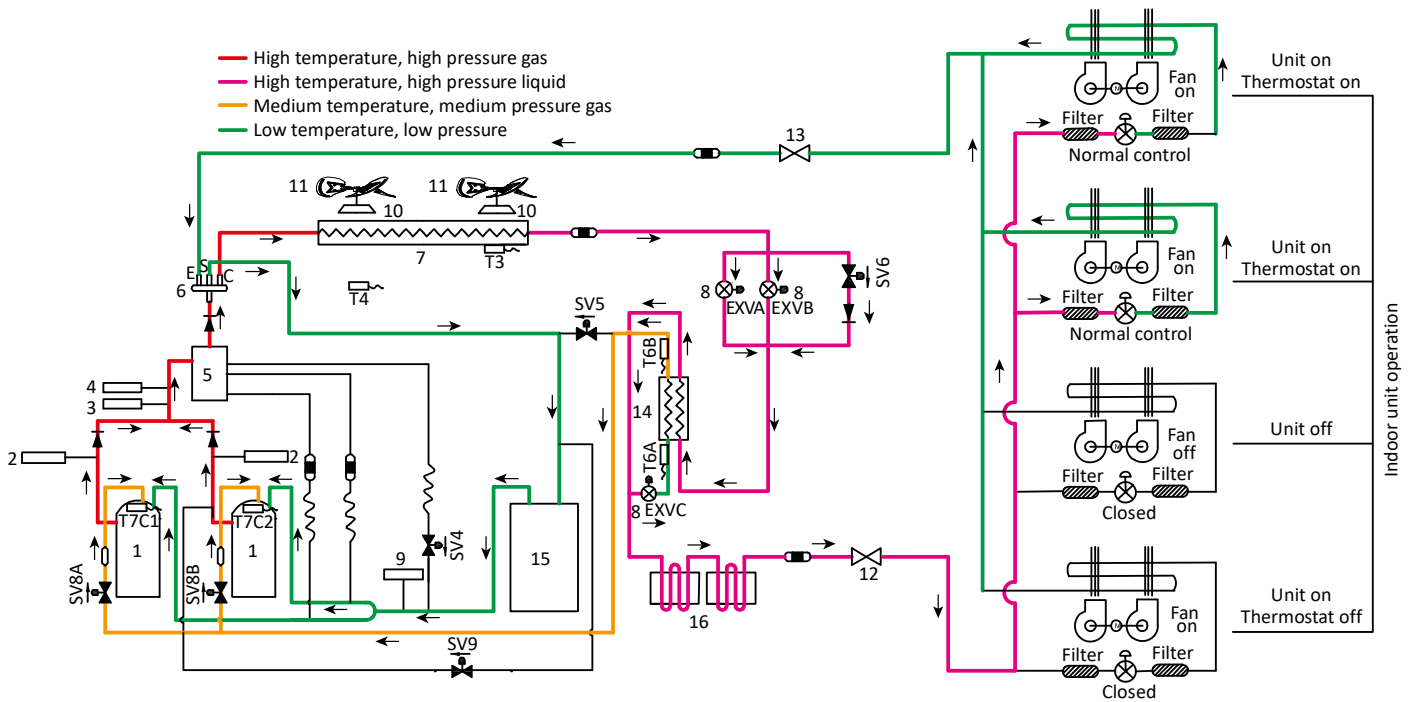

## Oil return operation in cooling mode

Figure 2-3.10: 18/20/22HP refrigerant flow during oil return operation in cooling mode

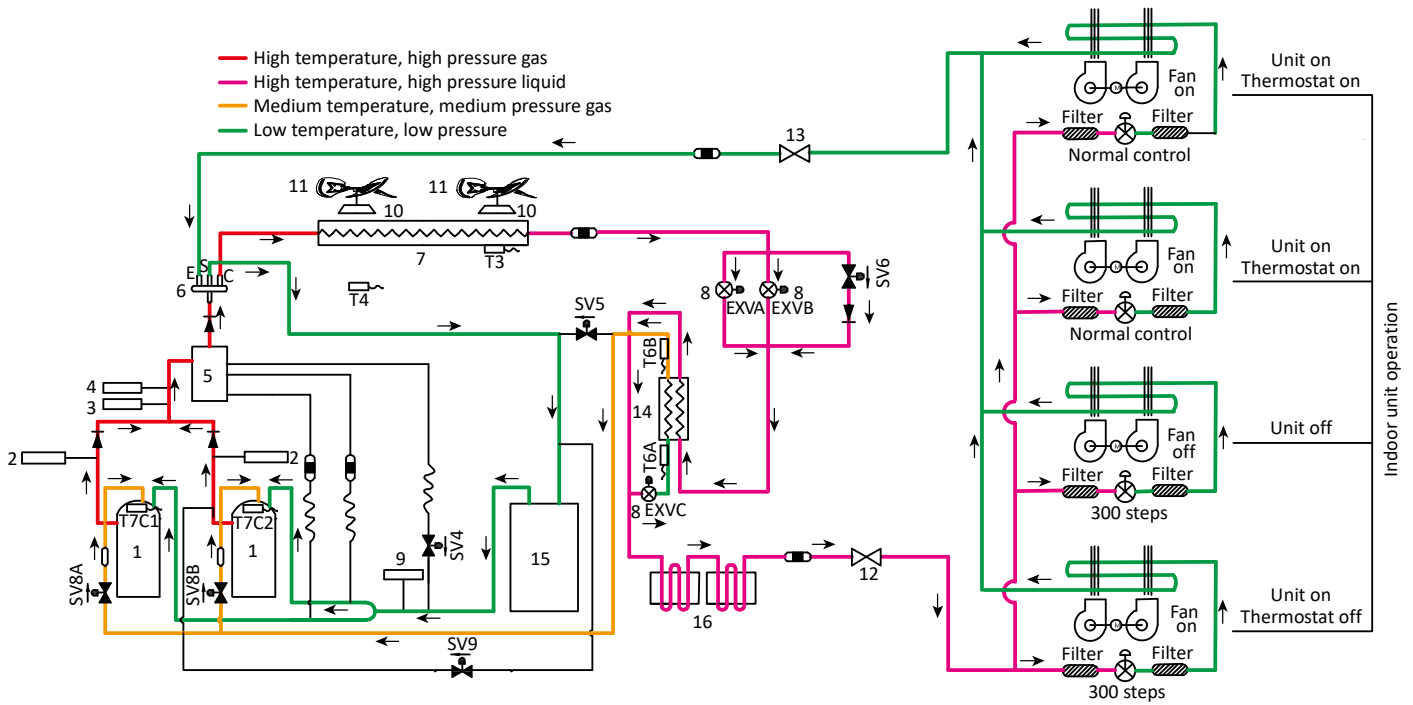

**Oil return operation in heating mode and defrosting operation**

Figure 2-3.11: 18/20/22HP refrigerant flow during oil return operation in heating mode and during defrosting operation

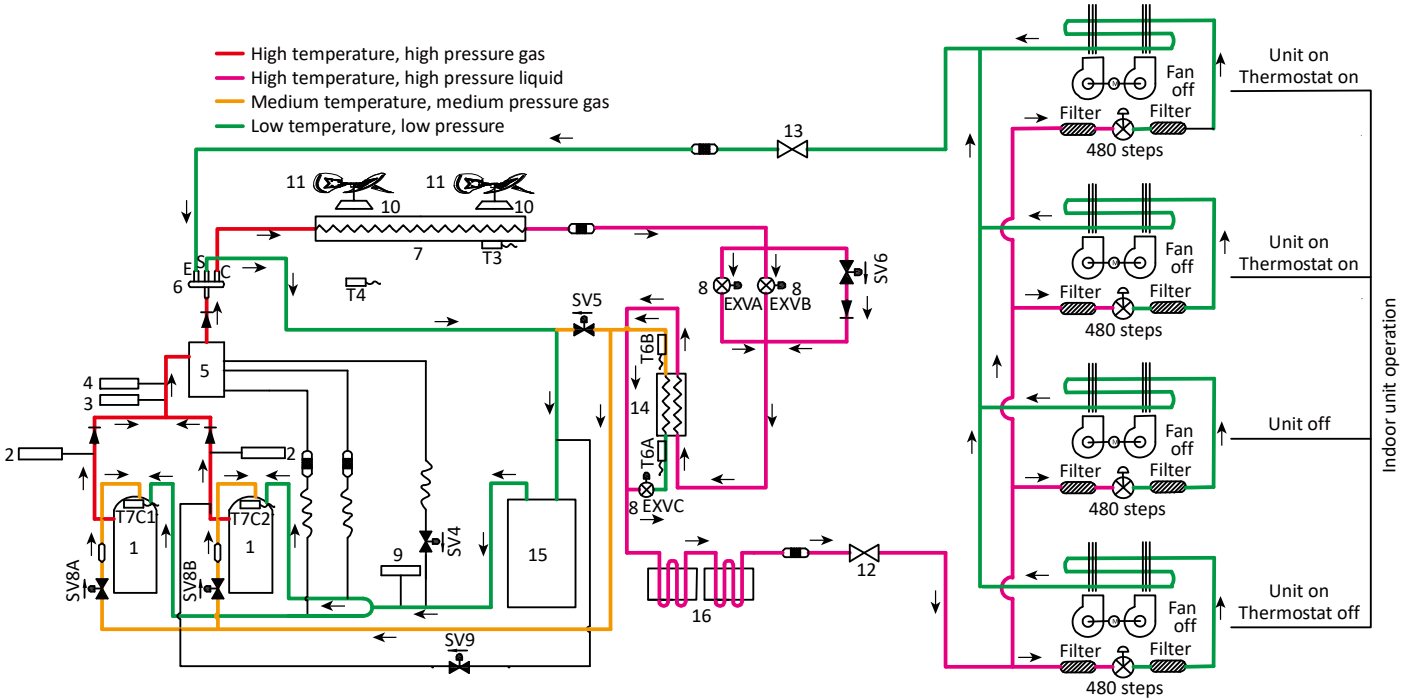

**Heating operation**

Figure 2-3.12: 18/20/22HP refrigerant flow during heating operation

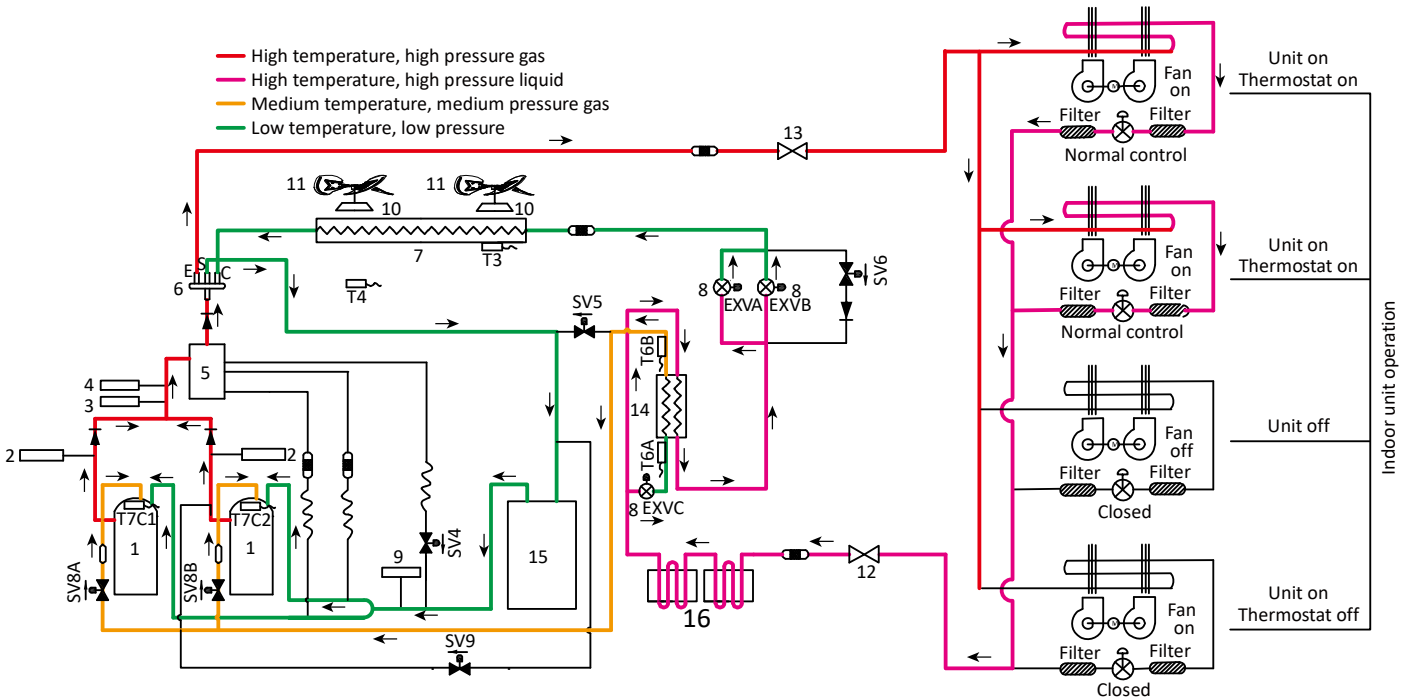

# Super X VRF 50/60Hz



24/26/28HP

## Cooling operation

Figure 2-3.13: 24/26/28 refrigerant flow during cooling operation

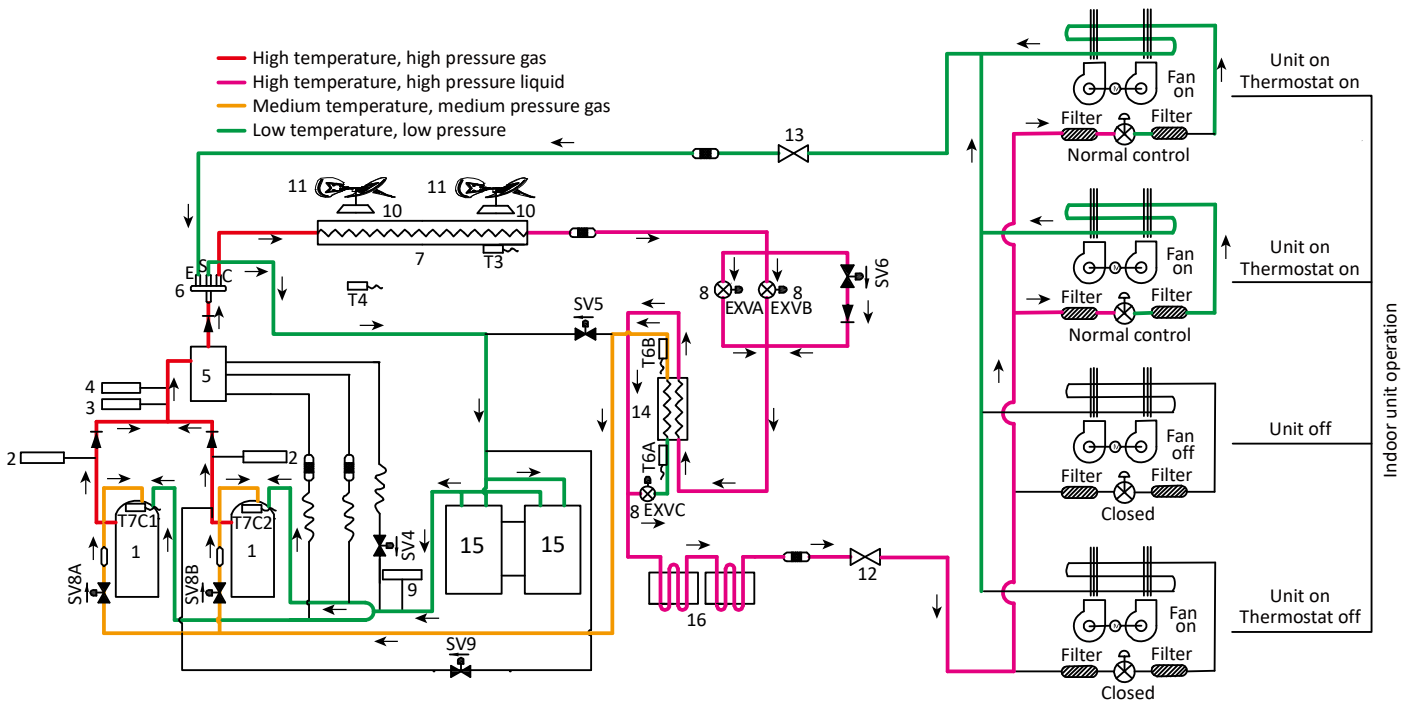

## Oil return operation in cooling mode

Figure 2-3.14: 24/26/28HP refrigerant flow during oil return operation in cooling mode

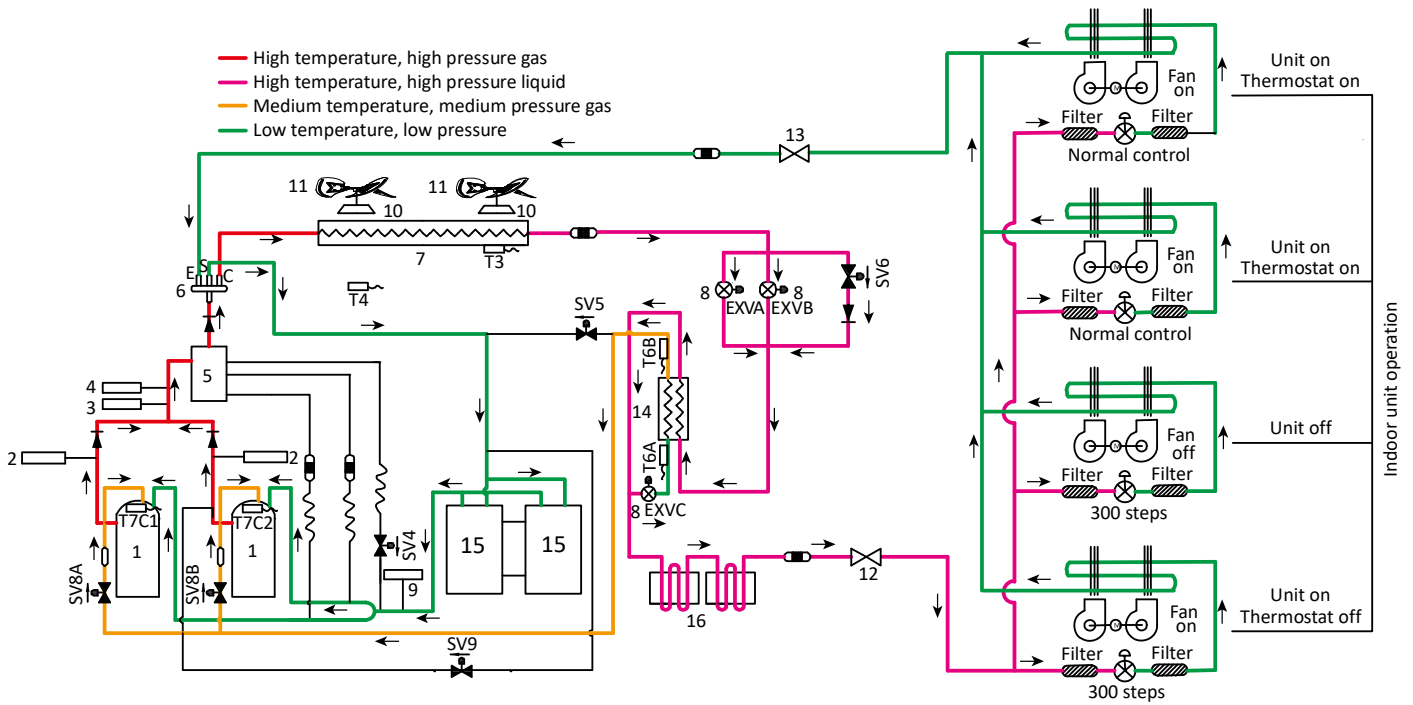

**Oil return operation in heating mode and defrosting operation**

Figure 2-3.15: 24/26/28HP refrigerant flow during oil return operation in heating mode and during defrosting operation

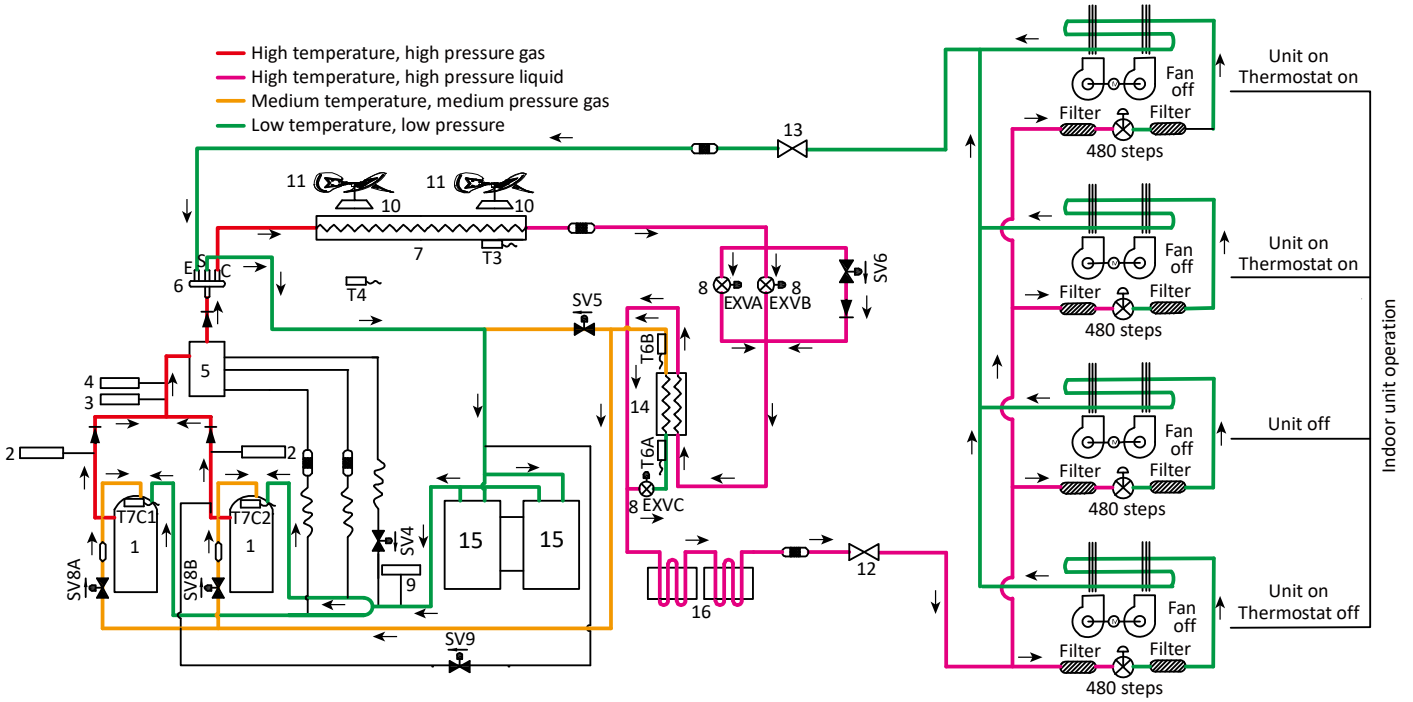

**Heating operation**

Figure 2-3.16: 24/26/28HP refrigerant flow during heating operation

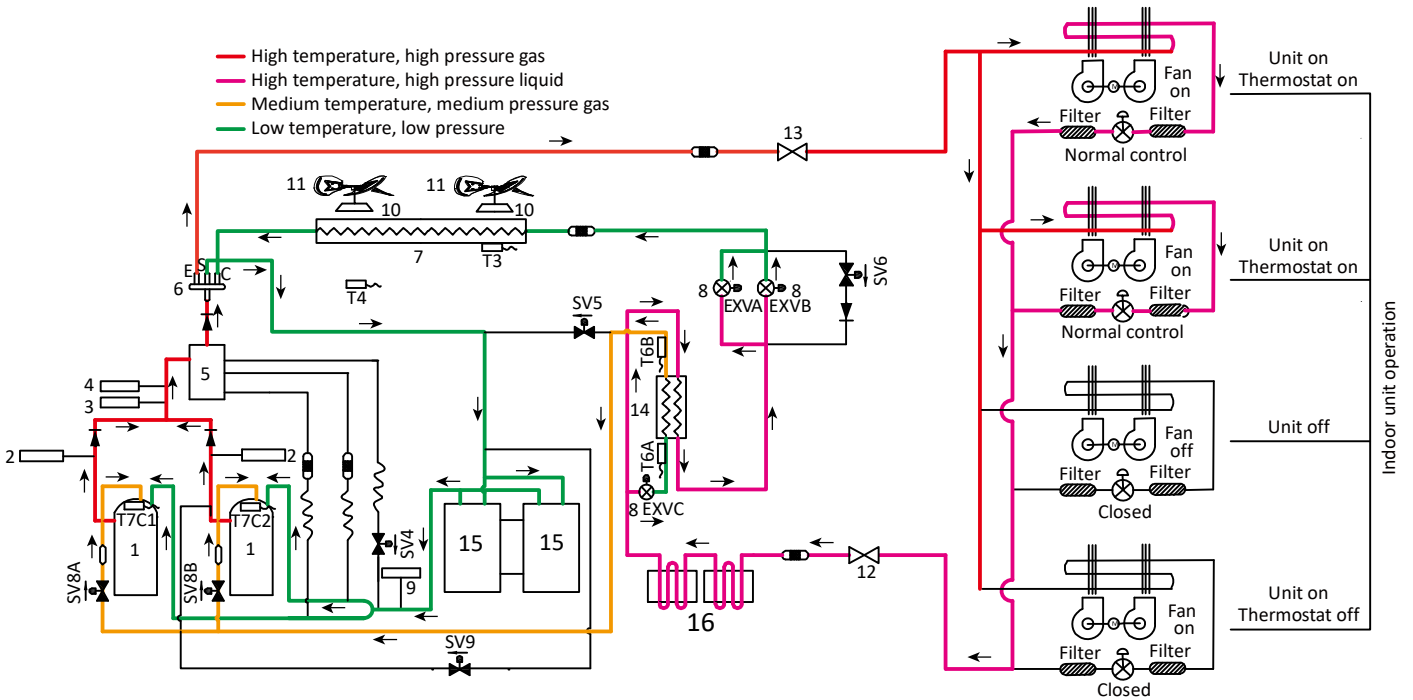

Indoor unit operation

Indoor unit operation

Indoor unit operation

## 30/32HP

### Cooling operation

Figure 2-3.17: 30/32 refrigerant flow during cooling operation

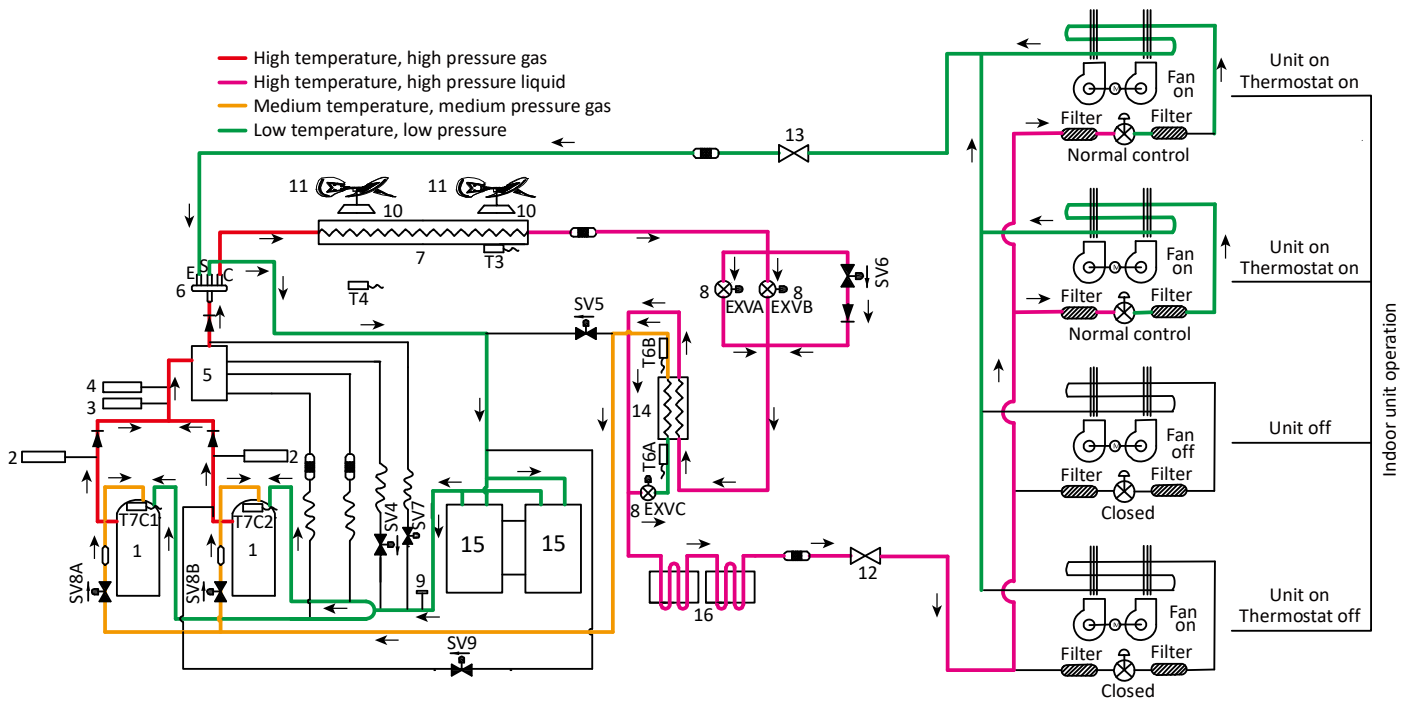

### Oil return operation in cooling mode

Figure 2-3.18: 30/32HP refrigerant flow during oil return operation in cooling mode

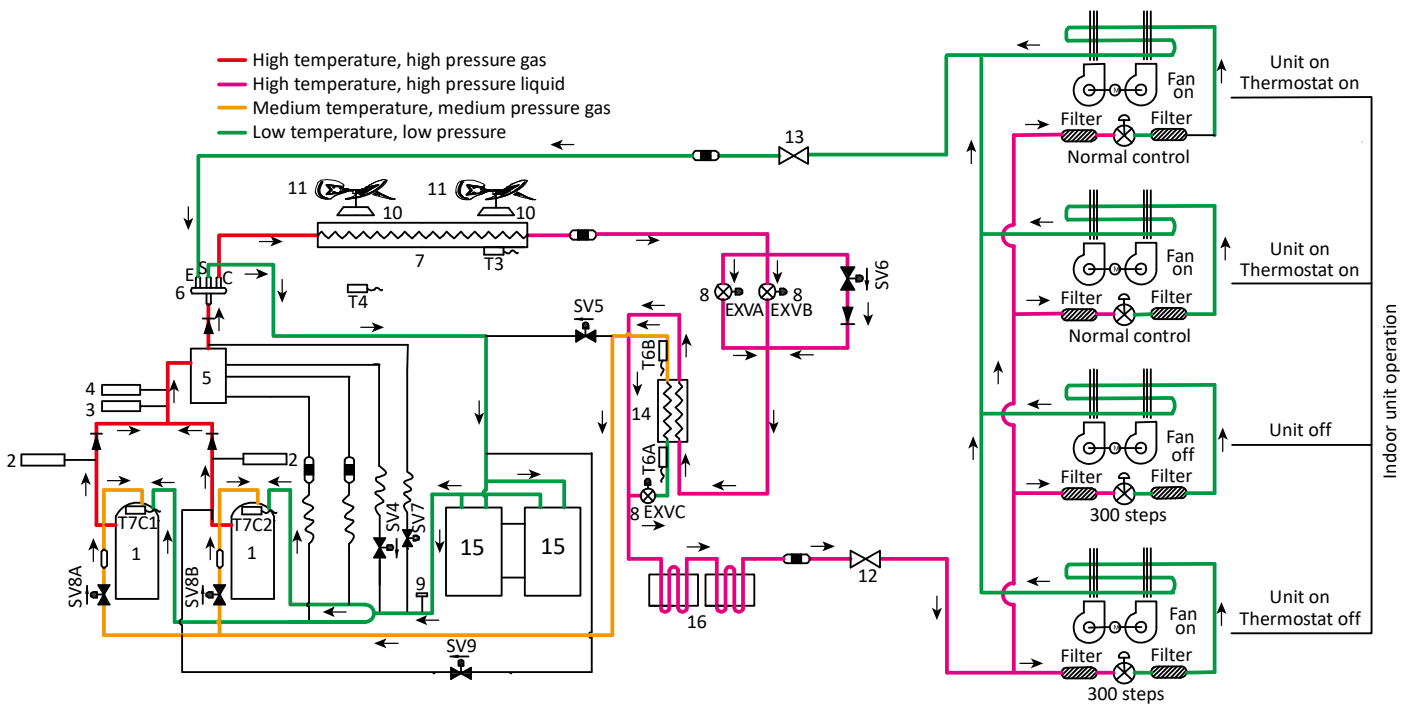

**Oil return operation in heating mode and defrosting operation**

Figure 2-3.19: 30/32HP refrigerant flow during oil return operation in heating mode and during defrosting operation

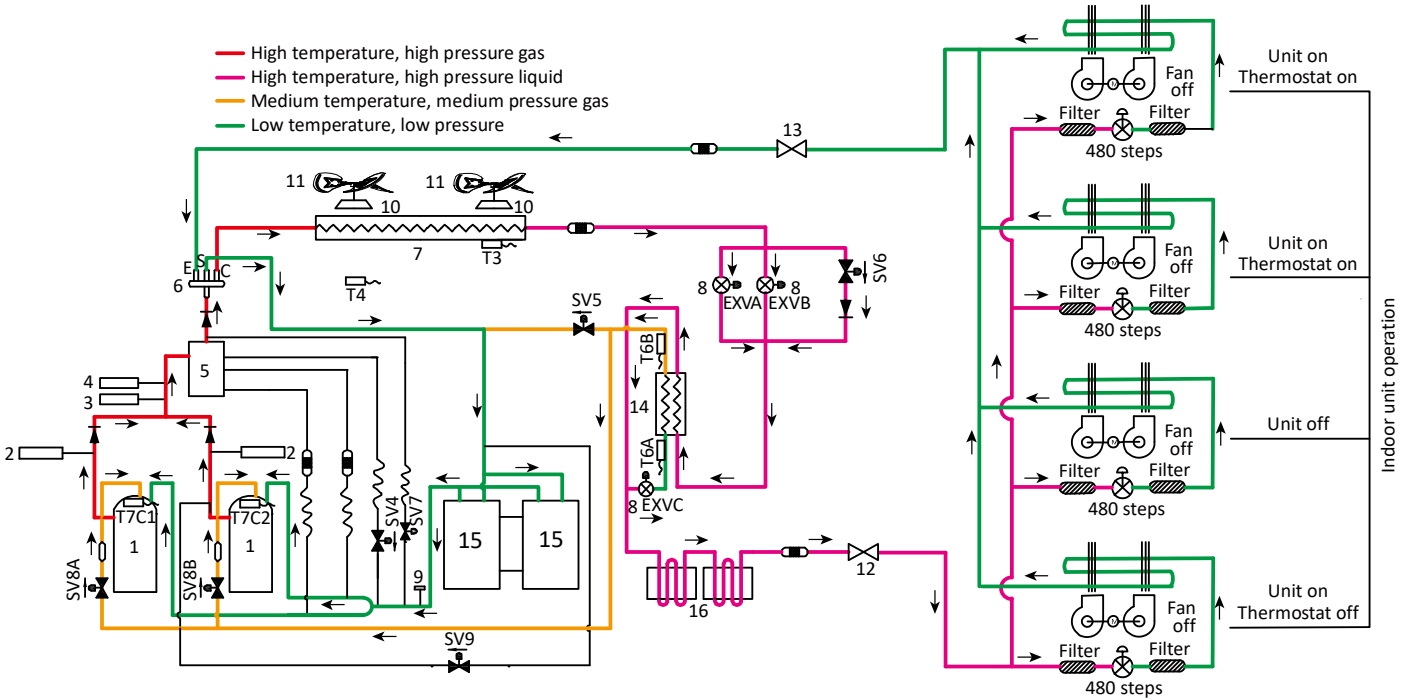

**Heating operation**

Figure 2-3.20: 30/32HP refrigerant flow during heating operation

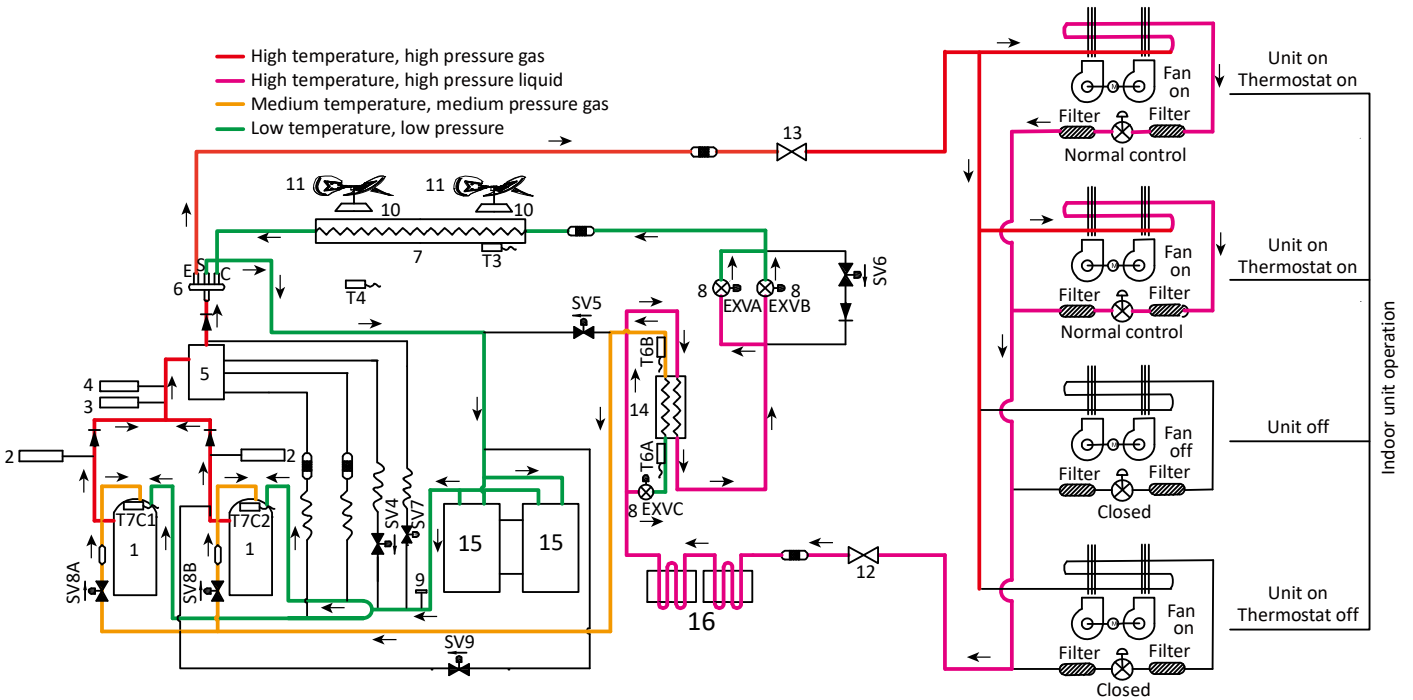





# Part 3

# Control

1	General Control Scheme Flowchart.....	34
2	Stop Operation .....	35
3	Standby Control.....	35
4	Startup Control .....	36
5	Normal Operation Control .....	38
6	Protection Control .....	43
7	Special Control.....	45

## 1 General Control Scheme Flowchart

Sections 3-2 to 3-7 on the following pages detail when each of the controls in the flowchart below is activated.

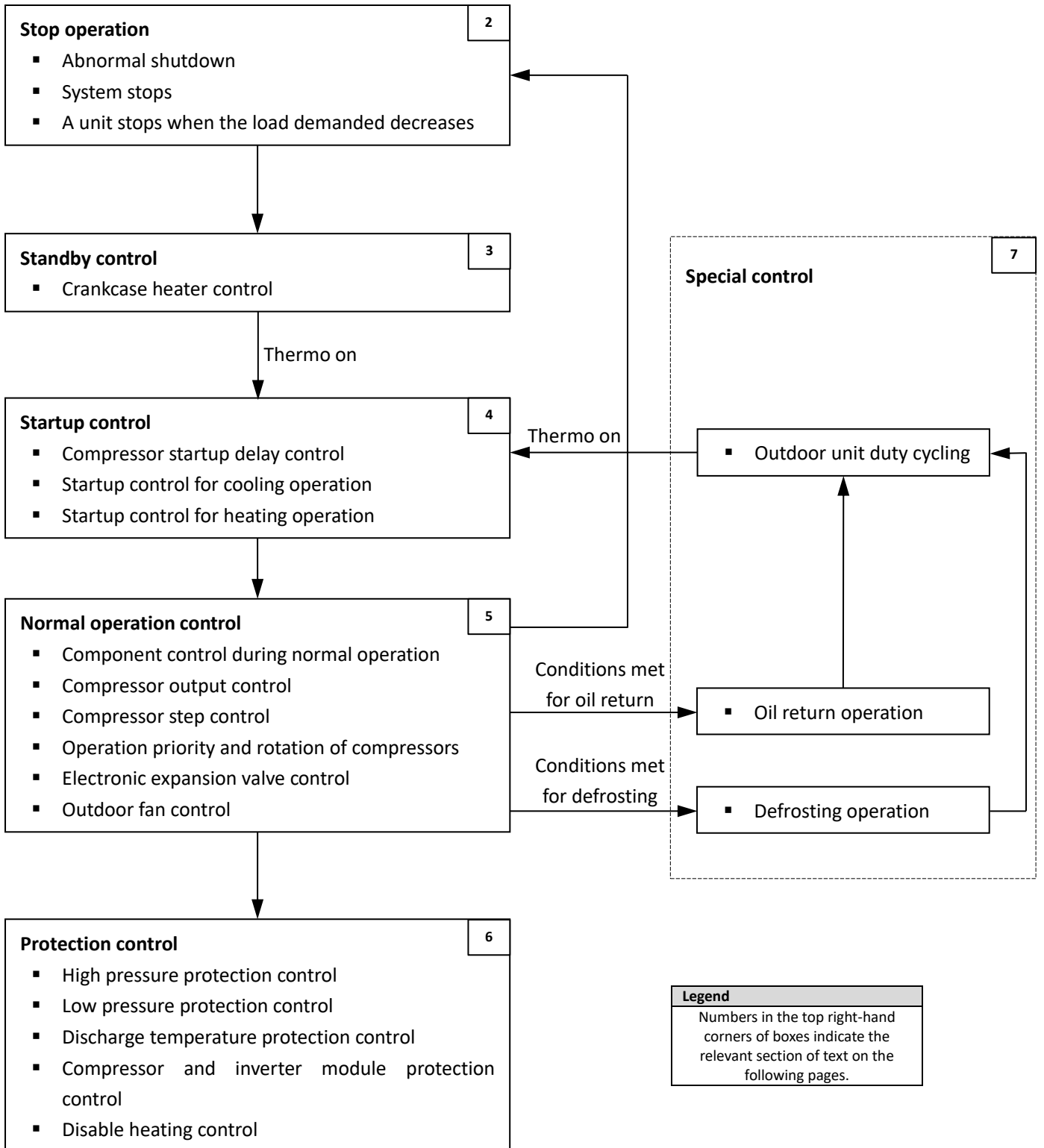

## 2 Stop Operation

The stop operation occurs for one of the three following reasons:

1. Abnormal shutdown: in order to protect the compressors, if an abnormal state occurs the system makes a 'stop with thermo off' operation and an error code is displayed on the outdoor unit digital displays.
2. The system stops when the set temperature has been reached.
3. A unit stops when the load demanded by the indoor units decreases and can be handled by fewer outdoor units.

When a unit stops because the load demanded by the indoor units has decreased and can be handled by fewer outdoor units, the unit's four-way valve remains on until the load demanded by the indoor units increases and the unit is required to operate. When the whole system stops, all the units' four-way valves turn off.

## 3 Standby Control

### 3.1 Crankcase Heater Control

The crankcase heater is used to prevent refrigerant from mixing with compressor oil when the compressors are stopped. The crankcase heater is controlled according to outdoor ambient temperature and discharge temperature. When the outdoor ambient temperature is above 40°C, the crankcase heater is off; when the outdoor ambient temperature is below 35°C, the crankcase heater is controlled according to discharge temperature. Refer to Figures 3-3.1 and 3-3.2.

Figure 3-3.1: Crankcase heater controlled according to outdoor ambient temperature

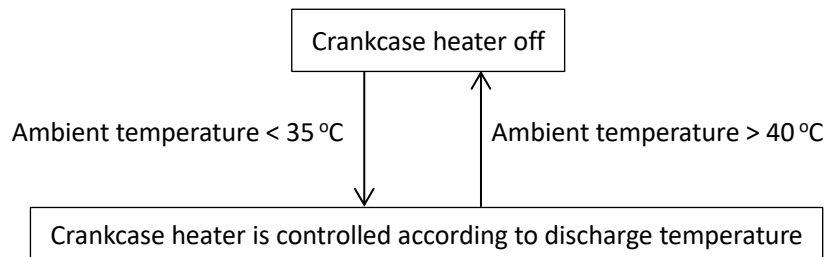
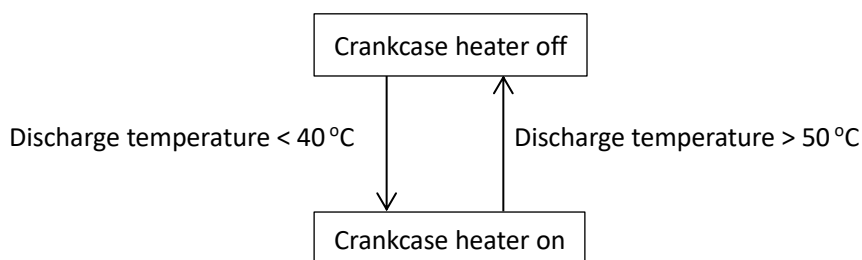

Figure 3-3.2: Crankcase heater controlled according to discharge temperature



## 4 Startup Control

### 4.1 Compressor Startup Delay Control

In initial startup control, compressor startup is delayed for 12 minutes in order to let the master unit search for the indoor units' addresses. In restart control (except in oil return operation and defrosting operation), compressor startup is delayed such that a minimum of 7 minutes has elapsed since the compressor stopped, in order to prevent frequent compressor on/off and to equalize the pressure within the refrigerant system.

### 4.2 Startup Control for Cooling Operation

Table 3-4.1: Component control during startup in cooling mode

Component	Wiring diagram label	8-12HP	14-16HP	18-28HP	30-32HP	Control functions and states
Inverter compressor A	COMP(A)	•	•	•	•	Controlled according to load requirement, operating frequency increased by 1 step / sec
Inverter compressor B	COMP(B)			•	•	
DC fan motor A	FANA	•	•	•	•	Fan speed <sup>1</sup> controlled according to discharge pressure (P <sub>c</sub> ): <ul style="list-style-type: none"> <li>▪ At initial speed for 90 seconds.</li> <li>▪ Subsequently, P<sub>c</sub> checked every 10 seconds:                             <ul style="list-style-type: none"> <li>• P<sub>c</sub> ≥ 2.7MPa =&gt; 1 step increase.</li> <li>• P<sub>c</sub> ≤ 2.1MPa =&gt; 1 step decrease.</li> </ul> </li> </ul>
DC fan motor B	FANB			•	•	
Electronic expansion valve A	EXVA	•	•	•	•	Position (steps) from 0 (fully closed) to 480 (fully open), controlled according to discharge temperature
Electronic expansion valve B	EXVB		•	•	•	
Electronic expansion valve C	EXVC	•	•	•	•	Position (steps) from 0 (fully closed) to 480 (fully open), controlled according to temperature different between plate heat exchanger inlet and outlet
Four-way valve	ST1	•	•	•	•	Off
Solenoid valve (oil balance)	SV4	•	•	•	•	Closed for 200 secs, open for 600 secs, then closed
Solenoid valve (fast defrosting (in heating) and unloading (in cooling))	SV5	•	•	•	•	Open for 4 mins, then closed
Solenoid valve (EXV bypass)	SV6	•	•	•	•	Open for 10 mins, then controlled according to pressure
Solenoid valve (indoor units bypass)	SV7		•		•	Controlled according to load requirement
Solenoid valve (inverter compressor A vapor injection)	SV8A	•	•	•	•	Controlled according to inverter compressor A
Solenoid valve (inverter compressor B vapor injection)	SV8B			•	•	Controlled according to inverter compressor B
Solenoid valve (inverter compressor B pressure balance)	SV9			•	•	Open before compressor B startup

Notes:

1. Refer to Table 3-5.3 in Part 3, 5.6 "Outdoor Fan Control" for more information on fan speed steps.

### 4.3 Startup Control for Heating Operation

Table 3-4.2: Component control during startup in heating mode

Component	Wiring diagram label	8-12HP	14-16HP	18-28HP	30-32HP	Control functions and states
Inverter compressor A	COMP(A)	•	•	•	•	Controlled according to load requirement, operating frequency increased by 1 step / sec
Inverter compressor B	COMP(B)			•	•	
DC fan motor A	FANA	•	•	•	•	Open once the four-way valve has opened, controlled according to outdoor ambient temperature and load requirement
DC fan motor B	FANB			•	•	
Electronic expansion valve A	EXVA	•	•	•	•	Position (steps) from 0 (fully closed) to 480 (fully open), controlled according to discharge superheat
Electronic expansion valve B	EXVB		•	•	•	
Electronic expansion valve C	EXVC	•	•	•	•	Position (steps) from 0 (fully closed) to 480 (fully open), controlled according to temperature different between plate heat exchanger inlet and outlet
Four-way valve	ST1	•	•	•	•	On
Solenoid valve (oil balance)	SV4	•	•	•	•	Closed for 200 secs, open for 600 secs, then closed
Solenoid valve (fast defrosting (in heating) and unloading (in cooling))	SV5	•	•	•	•	Open for 4 mins, then closed
Solenoid valve (EXV bypass)	SV6	•	•	•	•	Off
Solenoid valve (indoor units bypass)	SV7		•		•	Controlled according to load requirement
Solenoid valve (inverter compressor A vapor injection)	SV8A	•	•	•	•	Controlled according to inverter compressor A
Solenoid valve (inverter compressor B vapor injection)	SV8B			•	•	Controlled according to inverter compressor B
Solenoid valve (inverter compressor B pressure balance)	SV9			•	•	Open before compressor B startup

## 5 Normal Operation Control

### 5.1 Component Control during Normal Operation

Table 3-5.1: Component control during normal cooling operation

Component	Wiring diagram label	8-12HP	14-16HP	18-28HP	30-32HP	Control functions and states
Inverter compressor A	COMP(A)	•	•	•	•	Controlled according to load requirement
Inverter compressor B	COMP(B)			•	•	
DC fan motor A	FANA	•	•	•	•	Controlled according to discharge pressure
DC fan motor B	FANB			•	•	
Electronic expansion valve A	EXVA	•	•	•	•	Position (steps) from 0 (fully closed) to 480 (fully open), controlled according to discharge temperature
Electronic expansion valve B	EXVB		•	•	•	
Electronic expansion valve C	EXVC	•	•	•	•	Position (steps) from 0 (fully closed) to 480 (fully open), controlled according to temperature different between plate heat exchanger inlet and outlet
Four-way valve	ST1	•	•	•	•	On
Solenoid valve (oil balance)	SV4	•	•	•	•	Open regularly
Solenoid valve (fast defrosting (in heating) and unloading (in cooling))	SV5	•	•	•	•	Controlled according to ambient temperature, discharge pressure, discharge temperature, compressor running frequency and discharge superheat
Solenoid valve (EXV bypass)	SV6	•	•	•	•	Controlled according to discharge pressure and discharge temperature
Solenoid valve (indoor units bypass)	SV7		•		•	Controlled according to load requirement
Solenoid valve (inverter compressor A vapor injection)	SV8A	•	•	•	•	Controlled according to inverter compressor A on/off
Solenoid valve (inverter compressor B vapor injection)	SV8B			•	•	Controlled according to inverter compressor B on/off
Solenoid valve (inverter compressor B pressure balance)	SV9			•	•	Open before compressor B startup and close after compressor B running for 15 seconds. Open after compressor B stop 10 seconds and keep open 60 seconds.

Table 3-5.2: Component control during heating operation

Component	Wiring diagram label	8-12HP	14-16HP	18-28HP	30-32HP	Control functions and states
Inverter compressor A	COMP(A)	•	•	•	•	Controlled according to load requirement
Inverter compressor B	COMP(B)			•	•	
DC fan motor A	FANA	•	•	•	•	Controlled according to outdoor ambient temperature, outdoor heat exchanger pipe temperature, discharge pressure and load requirement
DC fan motor B	FANB			•	•	
Electronic expansion valve A	EXVA	•	•	•	•	Position (steps) from 0 (fully closed) to 480 (fully open), controlled according to discharge superheat
Electronic expansion valve B	EXVB		•	•	•	
Electronic expansion valve C	EXVC	•	•	•	•	Position (steps) from 0 (fully closed) to 480 (fully open), controlled according to temperature different between plate heat exchanger inlet and outlet
Four-way valve	ST1	•	•	•	•	On
Solenoid valve (oil balance)	SV4	•	•	•	•	Open regularly
Solenoid valve (fast defrosting (in heating) and unloading (in cooling))	SV5	•	•	•	•	Controlled according to ambient temperature, discharge pressure, discharge temperature, compressor running frequency and discharge superheat
Solenoid valve (EXV bypass)	SV6	•	•	•	•	Off
Solenoid valve (indoor units bypass)	SV7		•		•	Controlled according to load requirement
Solenoid valve (inverter compressor A vapor injection)	SV8A	•	•	•	•	Controlled according to inverter compressor A on/off
Solenoid valve (inverter compressor B vapor injection)	SV8B			•	•	Controlled according to inverter compressor B on/off
Solenoid valve (inverter compressor B pressure balance)	SV9			•	•	Open before compressor B startup and close after compressor B running for 15 seconds. Open after compressor B stop 10 seconds and keep open 60 seconds.



## 5.2 Compressor Output Control

The compressor rotation speed is controlled according to the load requirement. Before compressor startup, the outdoor units first estimate the indoor unit load requirement according to the nominal capacity of indoor units currently running, and then correct for ambient temperature. The compressors then start up according to the corrected load requirement.

During operation the compressors are controlled according to the nominal capacity of indoor units currently running and the indoor unit heat exchanger temperatures. If the actual load requirement can be provided by one unit alone, then only one unit starts up. If the actual load requirement requires all outdoor unit modules to operate, the weighted average actual load requirement is sent to each module and each module operates according to this distributed load requirement.

## 5.3 Compressor Step Control

The running speed of the compressors in rotations per second (rps) is one third of the frequency (in Hz) of the electrical input to the compressor motors. The compressor speed can be altered in increments of 1 rps.

## 5.4 Operating Priority and Rotation of Compressors

Figures 3-5.1 to 3-5.4 show the compressor operating priority and rotation in systems with one, two, three and four outdoor units. In units with two compressors, inverter compressor A (BP1) operates in priority to inverter compressor B (BP2). In multi-unit systems, units operate in rotation. In Figures 3-5.2 to 3-5.4 the master unit and slave units 1, 2 and 3 are shown from left to right in that order, and the circled numbers (①, ②, ③, ④) indicate the rotation sequence.

Figure 3-5.1: Compressor priority and rotation – one outdoor unit



Figure 3-5.2: Compressor priority and rotation – two outdoor units

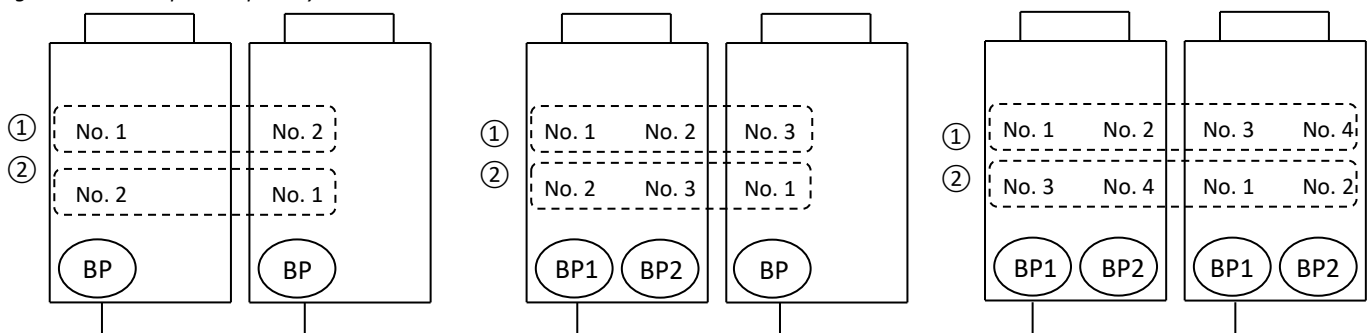
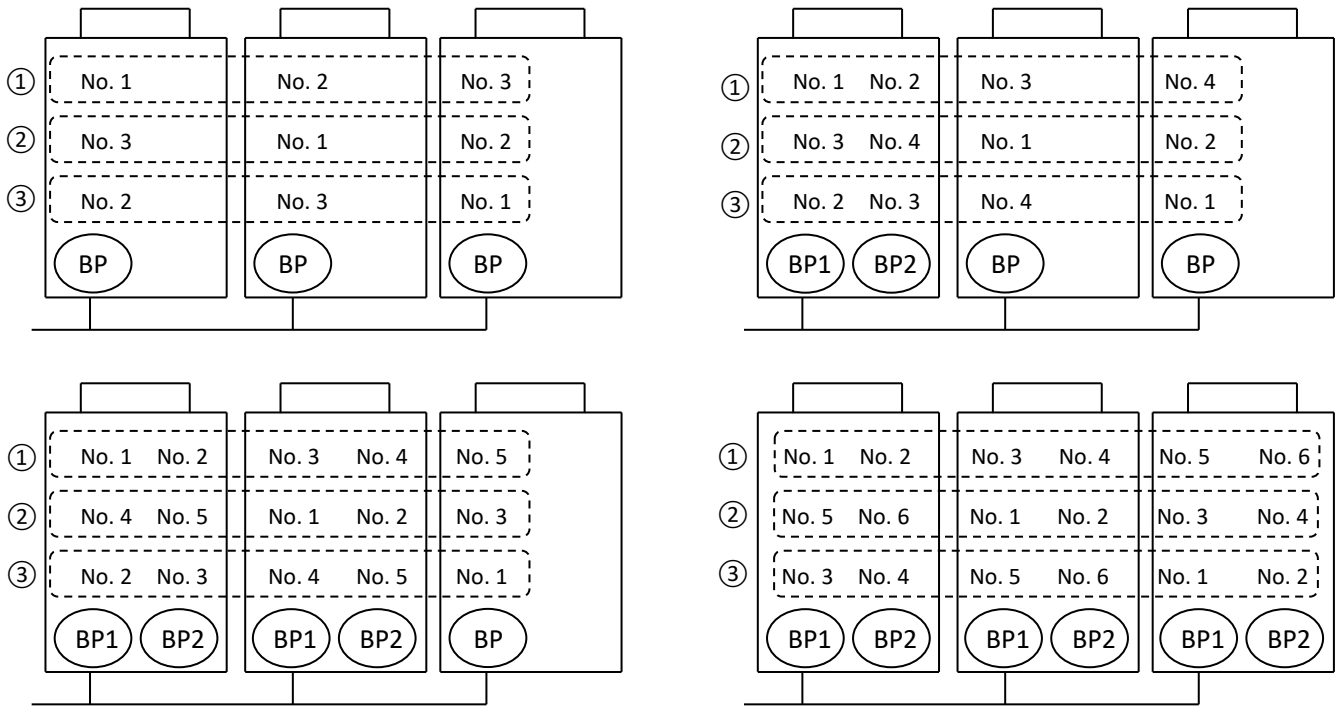

Figure 3-5.3: Compressor priority and rotation – three outdoor units



## 5.5 Electronic Expansion Valve Control

### EXVA and EXVB control

The positions of electronic expansion valves EXVA and EXVB are controlled in steps from 0 (fully closed) to 480 (fully open).

In cooling mode:

- When all outdoor units are in standby:
  - All EXVAs and EXVBs are at position 352 (steps).
- When some outdoor units are running and some outdoor units are in standby:
  - EXVAs and EXVBs on running outdoor units are controlled according to discharge temperature. EXVAs and EXVBs of units in standby are fully closed.
- When all outdoor units are running:
  - All EXVAs and EXVBs are controlled according to discharge temperature.

In heating mode:

- When all outdoor units are in standby:
  - All EXVAs and EXVBs are at position 352 (steps).
- When some outdoor units are running and some outdoor units are in standby:
  - EXVAs and EXVBs on running outdoor units are controlled according to discharge superheat. EXVAs and EXVBs of units in standby are fully closed.
- When all outdoor units are running:
  - All EXVAs and EXVBs are controlled according to discharge superheat.

### EXVC control

The positions of electronic expansion valves EXVC are controlled in steps from 0 (fully closed) to 480 (fully open).

In cooling / heating mode:

- When all outdoor units are in standby:

- All EXVCs are fully closed.
- When some outdoor units are running and some outdoor units are in standby:
  - EXVCs on running outdoor units are controlled according to temperature different between plate heat exchanger inlet and outlet. EXVCs of units in standby are fully closed.
- When all outdoor units are running:
  - All EXVCs are controlled according to temperature different between plate heat exchanger inlet and outlet.

## 5.6 Outdoor Fan Control

The speed of the outdoor unit fans is adjusted in steps, as shown in Table 3-5.3.

Table 3-5.3: Outdoor fan speed steps

Fan speed index	Fan speed (rpm)		
	8-16HP	18-22HP	24-32HP
		FANA / FANB	FANA / FANB
0	0	0 / 0	0 / 0
1	120	150 / 0	120 / 0
2	150	190 / 0	150 / 0
3	170	230 / 0	170 / 0
4	190	270 / 0	190 / 0
5	210	310 / 0 (150 / 150)	210 / 0
6	230	350 / 0 (180 / 180)	230 / 0
7	250	380 / 0 (210 / 210)	250 / 0 (120 / 120)
8	270	410 / 0 (240 / 240)	270 / 0 (150 / 150)
9	290	280 / 280	330 / 0 (170 / 170)
10	310	320 / 320	370 / 0 (190 / 190)
11	330	360 / 360	210 / 210
12	350	400 / 400	230 / 230
13	370	440 / 440	250 / 250
14	390	480 / 480	270 / 270
15	410	520 / 520	290 / 290
16	430	560 / 560	310 / 310
17	450	600 / 600	330 / 330
18	470	640 / 640	350 / 350
19	490	680 / 680	370 / 370
20	510	720 / 720	400 / 400
21	530	760 / 760	430 / 430
22	560	800 / 800	470 / 470
23	580	840 / 840	510 / 510
24	600	880 / 880	550 / 550
25	630	910 / 910	600 / 600
26	650	940 / 940	650 / 650
27	700	980 / 980	700 / 700
28	750	1010 / 1010	750 / 750
29	800	1020 / 1020	800 / 800
30	850	1050 / 1050	830 / 830
31	880	1080 / 1080	850 / 850
32	920	1120 / 1120	870 / 870
33	920	1140 / 1140	890 / 890
34	920	1140 / 1140	920 / 920
35	920	1140 / 1140	920 / 920
36 (ESP 40Pa mode)	950	1200 / 1200	950 / 950
37 (ESP 60Pa mode)	980	1200 / 1200	980 / 980

Note:

1. For 18-22HP unit fan speed 5 to 8 and 24-32HP unit fan speed 7 to 10, when fan speed decreases, the fan speed is shown in the bracket; when fan speed increases, the fan speed is shown without bracket.

## 6 Protection Control

### 6.1 High Pressure Protection Control

This control protects the system from abnormally high pressure and protects the compressors from transient spikes in pressure.

Figure 3-6.1: High pressure protection control

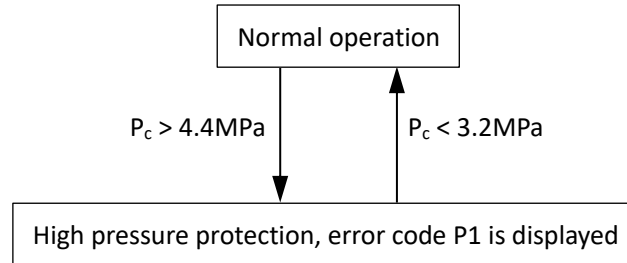

Notes:

1.  $P_c$ : Discharge pressure

### 6.2 Low Pressure Protection Control

This control protects the system from abnormally low pressure and protects the compressors from transient drops in pressure.

Figure 3-6.2: Low pressure protection control

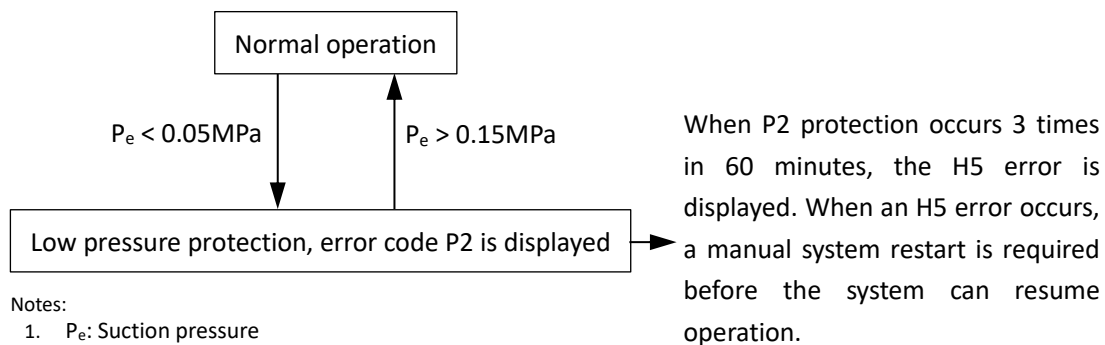

Notes:

1.  $P_e$ : Suction pressure

### 6.3 Discharge Temperature Protection Control

This control protects the compressors from abnormally high temperatures and transient spikes in temperature. It is performed for each compressor.

Figure 3-6.3: Discharge temperature protection control

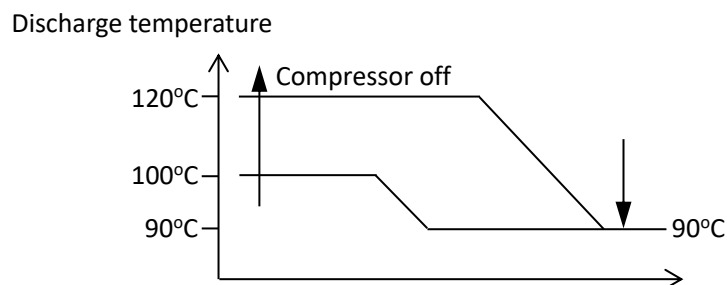

When the discharge temperature rises above 120°C the system displays P4 protection and all units stop running. When P4 protection occurs 3 times in 100 minutes, the H6 error is displayed. When an H6 error occurs, a manual system restart is required before the system can resume operation.

### 6.4 Compressor and Inverter Module Protection Control

This control protects the compressors from abnormally high currents and protects the inverter modules from abnormally

high temperatures. It is performed for each compressor and inverter module.

Figure 3-6.4: Compressor current protection control

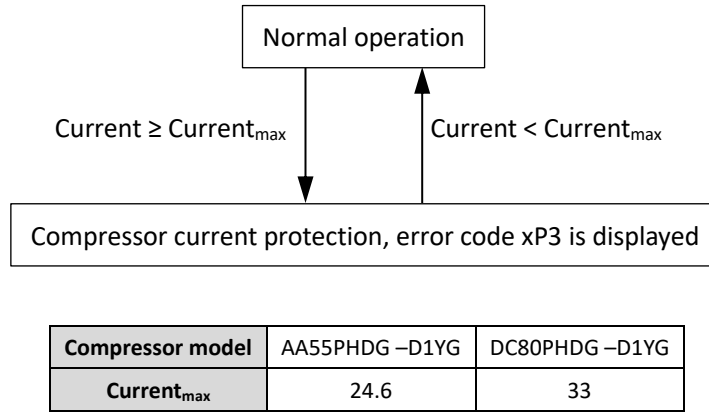
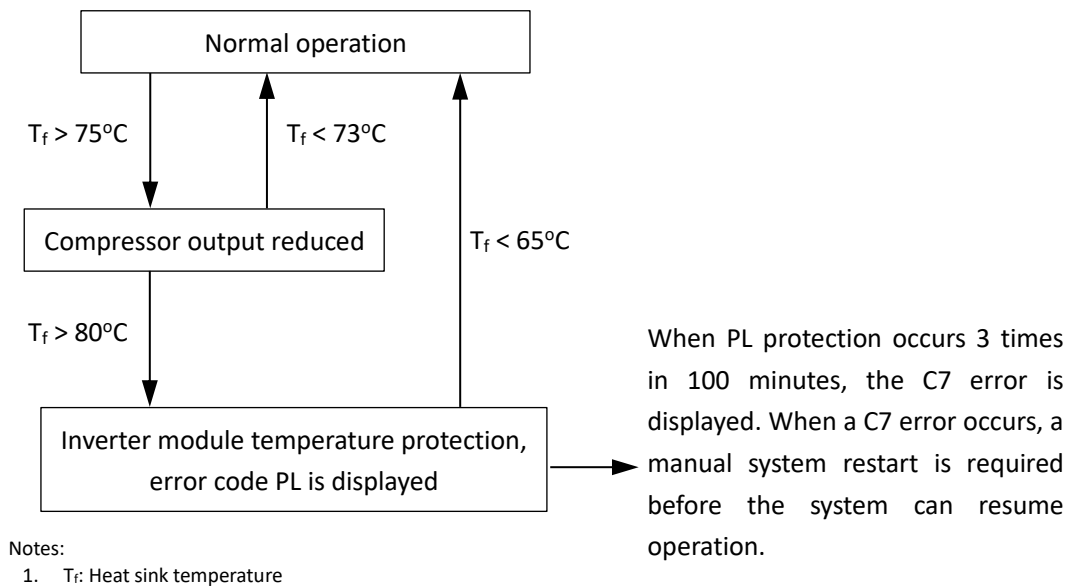

Figure 3-6.5: Inverter module temperature protection control



## 6.5 Disable Heating Control

When the outdoor ambient temperature rises above 25°C heating mode is disabled to prevent the mechanical load on compressors becoming too high and to prevent low compression ratios which can result in insufficient compressor internal oil lubrication.

Figure 3-6.6: Disable heating control

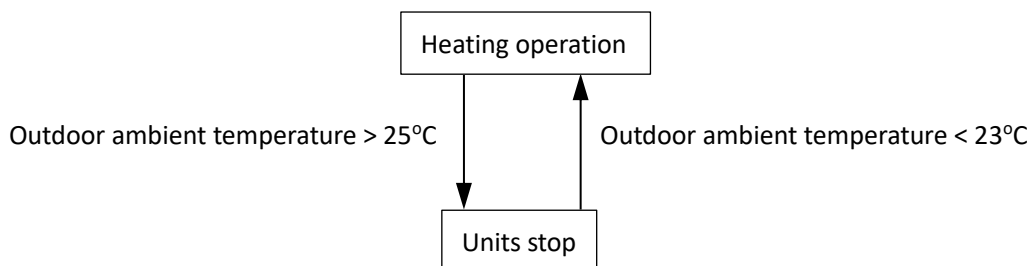

## 7 Special Control

### 7.1 Outdoor Unit Duty Cycling

In systems with multiple outdoor units, outdoor unit duty cycling is used to prevent compressor burn out due to unbalanced oil levels between outdoor units.

Timing of outdoor unit duty cycling:

- After oil return operation.
- After defrosting operation.
- On restart following compressor stop after set temperatures achieved.

Figure 3-7.1 shows an example of duty cycling in a system with 3 outdoor units.

Figure 3-7.1: Duty cycling in a system with 3 outdoor units<sup>1</sup>

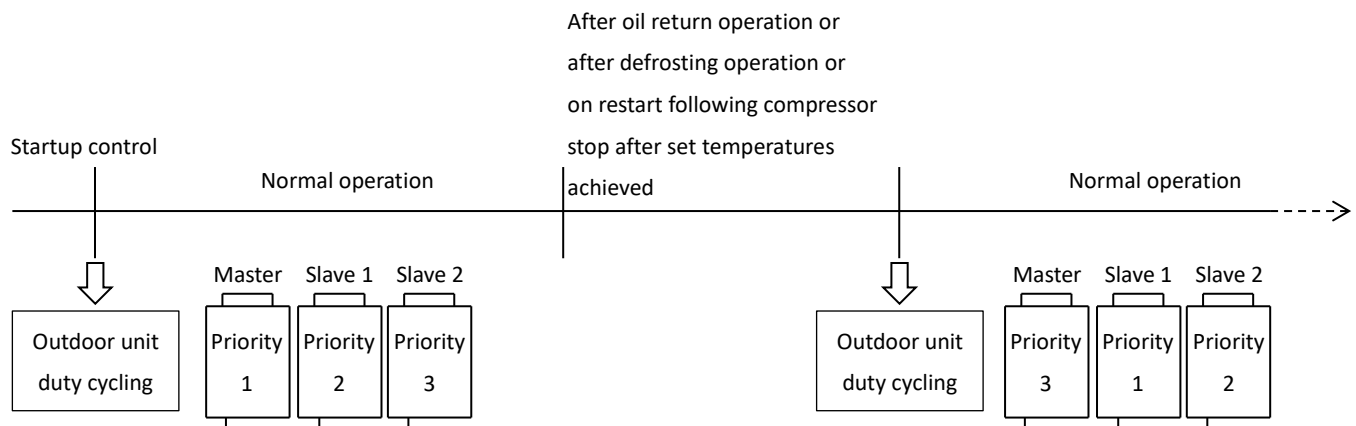

Notes:

1. The address settings on the outdoor unit main PCBs for "master unit", "slave unit 1", and "slave unit 2" do not change.

### 7.2 Oil Return Operation

In order to prevent compressors from running out of oil, the oil return operation is conducted to recover oil that has flowed out of the compressor(s) and into the piping system. This operation is performed for all units including units that are in standby. When the outdoor unit is running in oil return, the digital display on outdoor main PCB will display "d0".

Timing of oil return operation:

- When the initial cumulative operating time reaches 140 minutes and then every 8 hours.

Tables 3-7.1 and 3-7.2 show component control during oil return operation in cooling mode.

Table 3-7.1: Outdoor unit component control during oil return operation in cooling mode

Component	Wiring diagram label	8-12HP	14-16HP	18-28HP	30-32HP	Control functions and states
Inverter compressor A	COMP(A)	•	•	•	•	Fixed frequency
Inverter compressor B	COMP(B)			•	•	
DC fan motor A	FANA	•	•	•	•	Fan speed controlled according to discharge pressure
DC fan motor B	FANB			•	•	
Electronic expansion valve A	EXVA	•	•	•	•	Position 480 (steps)
Electronic expansion valve B	EXVB		•	•	•	
Electronic expansion valve C	EXVC	•	•	•	•	Position 96 (steps)
Four-way valve	ST1	•	•	•	•	Off
Solenoid valve (oil balance)	SV4	•	•	•	•	Normal control
Solenoid valve (fast defrosting (in heating) and unloading (in cooling))	SV5	•	•	•	•	On
Solenoid valve (EXV bypass)	SV6	•	•	•	•	On
Solenoid valve (indoor units bypass)	SV7		•		•	Normal control
Solenoid valve (inverter compressor A vapor injection)	SV8A	•	•	•	•	Controlled according to inverter compressor A
Solenoid valve (inverter compressor B vapor injection)	SV8B			•	•	Controlled according to inverter compressor B
Solenoid valve (inverter compressor B pressure balance)	SV9			•	•	Open before compressor B startup

Table 3-7.2: Indoor unit component control during oil return operation in cooling mode

Component	Unit state	Control functions and states
Fan	Thermo on	Remote controller setting
	Standby	Off
	Thermo off	Off
Electronic expansion valve	Thermo on	Normal control
	Standby	300 (steps)
	Thermo off	300 (steps)

Tables 3-7.3 and 3-7.4 show component control during oil return operation in heating mode.

*Table 3-7.3: Outdoor unit component control during oil return operation in heating mode*

Component	Wiring diagram label	8-12HP	14-16HP	18-28HP	30-32HP	Control functions and states
Inverter compressor A	COMP(A)	•	•	•	•	Fixed frequency
Inverter compressor B	COMP(B)			•	•	
DC fan motor A	FANA	•	•	•	•	Fan speed controlled according to discharge pressure
DC fan motor B	FANB			•	•	
Electronic expansion valve A	EXVA	•	•	•	•	Position 480 (steps)
Electronic expansion valve B	EXVB		•	•	•	
Electronic expansion valve C	EXVC	•	•	•	•	Position 96 (steps)
Four-way valve	ST1	•	•	•	•	Off
Solenoid valve (oil balance)	SV4	•	•	•	•	Normal control
Solenoid valve (fast defrosting (in heating) and unloading (in cooling))	SV5	•	•	•	•	On
Solenoid valve (EXV bypass)	SV6	•	•	•	•	On
Solenoid valve (indoor units bypass)	SV7		•		•	Normal control
Solenoid valve (inverter compressor A vapor injection)	SV8A	•	•	•	•	Off
Solenoid valve (inverter compressor B vapor injection)	SV8B			•	•	Off
Solenoid valve (inverter compressor B pressure balance)	SV9			•	•	Open before compressor B startup

*Table 3-7.4: Indoor unit component control during oil return operation in heating mode*

Component	Unit state	Control functions and states
Fan	Thermo on	Off
	Standby	Off
	Thermo off	Off
Electronic expansion valve	Thermo on	480 (steps)
	Standby	480 (steps)
	Thermo off	480 (steps)



## 7.3 Defrosting Operation

In order to recover heating capacity, the defrosting operation is conducted when the outdoor unit heat exchanger is performing as an evaporator. The defrosting operation is controlled according to outdoor ambient temperature, outdoor heat exchanger temperature, indoor heat exchanger temperature and outdoor units running time. When the outdoor unit is running in defrosting, the digital display on outdoor main PCB will display “df”.

Table 3-7.5: Outdoor unit component control during defrosting operation

Component	Wiring diagram label	8-12HP	14-16HP	18-28HP	30-32HP	Control functions and states
Inverter compressor A	COMP(A)	•	•	•	•	Fixed frequency
Inverter compressor B	COMP(B)			•	•	
DC fan motor A	FANA	•	•	•	•	Off
DC fan motor B	FANB			•	•	
Electronic expansion valve A	EXVA	•	•	•	•	Position 480 (steps)
Electronic expansion valve B	EXVB		•	•	•	
Electronic expansion valve C	EXVC	•	•	•	•	Position 480 (steps)
Four-way valve	ST1	•	•	•	•	Off
Solenoid valve (oil balance)	SV4	•	•	•	•	Normal control
Solenoid valve (fast defrosting (in heating) and unloading (in cooling))	SV5	•	•	•	•	On
Solenoid valve (EXV bypass)	SV6	•	•	•	•	On
Solenoid valve (indoor units bypass)	SV7		•		•	Normal control
Solenoid valve (inverter compressor A vapor injection)	SV8A	•	•	•	•	Off
Solenoid valve (inverter compressor B vapor injection)	SV8B			•	•	Off
Solenoid valve (inverter compressor B pressure balance)	SV9			•	•	Open before compressor B startup

Table 3-7.6: Indoor unit component control during defrosting operation

Component	Unit state	Control functions and states
Fan	Thermo on	Off
	Standby	Off
	Thermo off	Off
Electronic expansion valve	Thermo on	480 (steps)
	Standby	480 (steps)
	Thermo off	480 (steps)

# Part 4

# Field Settings

1 Outdoor Unit Field Settings ..... 50

## 1 Outdoor Unit Field Settings

### 1.1 PCB Switches and Switch Settings

Figure 4-1.1: Outdoor unit main PCB switches

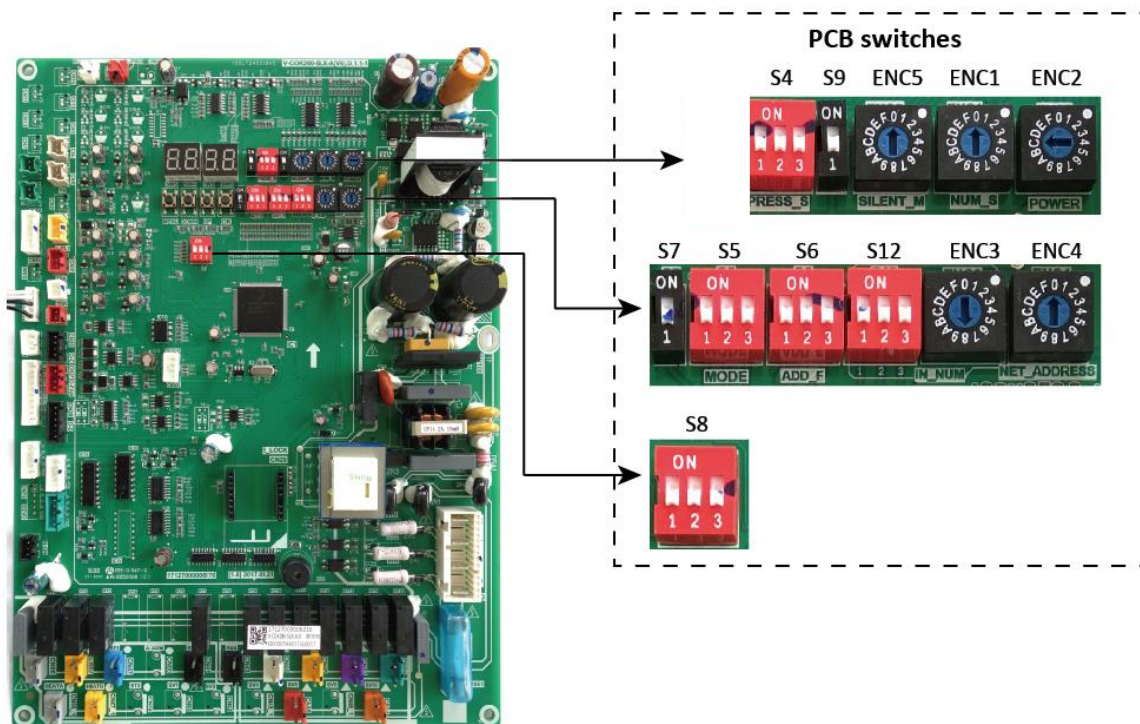

Table 4-1.1: Outdoor unit main PCB switch settings



















Switch	Setting	Switch positions <sup>1</sup>	Description
 S4	Static pressure	ON 	Standard static pressure (default)
		ON 	Low static pressure mode (reserved)
		ON 	Medium static pressure mode (reserved)
		ON 	High static pressure mode (reserved)
		ON 	Super high static pressure mode (reserved)
 S5	Priority mode <sup>2</sup>	ON 	Auto priority (default)
		ON 	Cooling priority
		ON 	VIP priority or voting priority
		ON 	Heating only
		ON 	Cooling only
		ON 	Set priority mode via centralized controller (reserved)
 S6-1	Reserved	ON 	Reserved
 S6-2	Clear indoor unit addresses	ON 	No action (default)
		ON 	Clear indoor unit addresses

Table continued on next page ...

Table 4-1.1: Outdoor unit main PCB switch settings (continued)

Switch	Setting	Switch positions <sup>1</sup>	Description
S6-3	Addressing mode		Auto addressing (default)
			Manual addressing
S8-1	Reserved		Reserved
S8-2	Start-up time		Start-up time is 12 minutes (default)
			Start-up time is 7 minutes
S8-3	Reserved		Reserved
S7	Reserved		Reserved
S9	Reserved		Reserved
S13	Controller type		Use the new centralized controller (CCM-180A/WS & CCM-270A/WS) (default)
			Use the old centralized controller
ENC1	Outdoor unit address		Only 0, 1, 2 should be selected (default is 0) 0 is for master unit; 1 and 2 are for slave units
ENC2	Outdoor unit capacity <sup>3</sup>		Only 0, 1, 2, 3, 4, 5, 6, 7, 8, 9, A, B, C should be selected 0: 8HP; 1: 10HP; 2: 12HP; 3: 14HP; 4: 16HP; 5: 18HP; 6: 20HP; 7: 22HP; 8: 24HP; 9: 26HP; A: 28HP; B:30HP; C:32HP
ENC4	Network address		Only 0, 1, 2, 3, 4, 5, 6, 7 should be selected (default is 0)
ENC3  S12	Number of indoor units	ON	The number of indoor units is in the range 0-15 0-9 on ENC3 indicate 0-9 indoor units; A-F on ENC3 indicate 10-15 indoor units
		ON	The number of indoor units is in the range 16-31 0-9 on ENC3 indicate 16-25 indoor units; A-F on ENC3 indicate 26-31 indoor units
		ON	The number of indoor units is in the range 32-47 0-9 on ENC3 indicate 32-41 indoor units; A-F on ENC3 indicate 42-47 indoor units
		ON	The number of indoor units is in the range 48-63 0-9 on ENC3 indicate 48-57 indoor units; A-F on ENC3 indicate 58-63 indoor units
ENC5	Silent mode <sup>4</sup>	0	Night silent time is 6h/10h (default)
		1	Night silent time is 6h/12h
		2	Night silent time is 8h/10h
		3	Night silent time is 8h/12h
		4	No silent mode
		5	Silent mode 1 (only limit max. fan speed)
		6	Silent mode 2 (only limit max. fan speed)
		7	Silent mode 3 (only limit max. fan speed)
		8	Super silent mode 1 (limit max. fan speed and compressor frequency)
		9	Super silent mode 2 (limit max. fan speed and compressor frequency)
A	Super silent mode 3 (limit max. fan speed and compressor frequency)		
B	Super silent mode 4 (limit max. fan speed and compressor frequency)		
F	Set silent mode via centralized controller (reserved)		

Notes:

1. Black denotes the switch position.
2. Refer to Part 4, 1.2.1 "Priority mode setting".
3. Switch ENC2 is factory-set and its setting should not be changed.
4. Refer to Part 4, 1.2.2 "Silent mode setting".

## 1.2 Modes Set on Main PCB

### 1.2.1 Priority mode setting

Priority mode can only be set on the master unit. When an indoor unit is in mode conflict with the outdoor units the unit displays the mode conflict error. If the indoor unit has a digital display, it will display error code E0; if the indoor unit display board has LED indicators, the “DEF./FAN” LED will flash rapidly.

Figure 4-1.2: Indoor unit digital displays and LED indicators



There are five priority mode options:

1. **Auto priority mode (default):** In auto priority mode, the outdoor unit will operate in heating priority mode or cooling priority mode according to the outdoor ambient temperature.
  - a) When the outdoor ambient temperature is below 13°C, the outdoor units run in heating priority mode. The heating priority mode does not change until the outdoor ambient temperature is above 18°C.
  - b) When the outdoor ambient temperature is above 18°C, the outdoor units run in cooling priority mode. The cooling priority mode does not change until the outdoor ambient temperature is below 13°C.
  - c) When the outdoor units restart under the outdoor ambient between 13°C and 18°C, the outdoor units run the same priority as before the last stop.
  - d) When the outdoor unit is initial startup under outdoor ambient temperature between 13°C and 18°C, the outdoor units run in heating priority mode.

Figure 4-1.3: Auto priority mode control

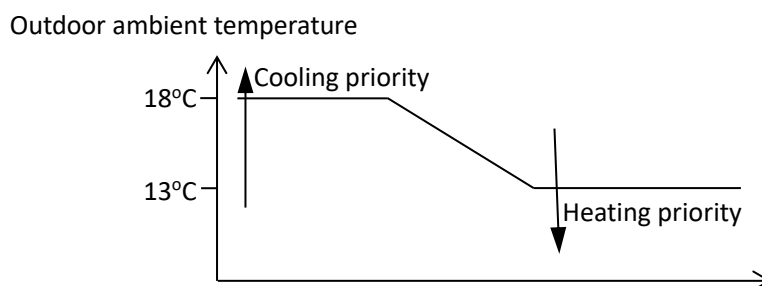

#### 1.1. Heating priority mode:

- a) **During cooling operation:** If an indoor unit requests heating, the outdoor units stop and then restart in heating mode after 5 minutes. Indoor units requesting heating then start in heating mode and indoor units requesting cooling display the mode conflict error.
- b) **During heating operation:** If an indoor unit requests cooling, the outdoor units ignore the request and continue to run in heating mode. The indoor unit requesting cooling displays the mode conflict error. If all the indoor units requesting heating are later turned off and one or more indoor units are still requesting cooling, the outdoor units restart in cooling mode after 5 minutes and any indoor units requesting cooling then start in cooling mode.

#### 1.2. Cooling priority mode:

- a) **During heating operation:** If an indoor unit requests cooling, the outdoor units stop and then restart in cooling mode after 5 minutes. Indoor units requesting cooling then start in cooling mode and indoor units requesting heating display the mode conflict error.
- b) **During cooling operation:** If an indoor unit requests heating, the outdoor units ignore the request and continue to run in cooling mode. The indoor unit requesting heating displays the mode conflict error. If all the indoor units requesting cooling are later turned off and one or more indoor units are still requesting heating, the outdoor units restart in heating mode after 5 minutes and any indoor units requesting heating then start in heating

mode.

2. **Cooling priority mode:** refer to above “1.2. Cooling priority mode” descriptions.
3. **VIP priority mode or voting priority mode:** The default VIP address is 63, the VIP address also can be changed through menu mode, refer to Part 5, 1.2.3 “Menu mode” Table 5-1.3 “nb8”. If the VIP indoor unit is operating, the outdoor units operate in the mode of the VIP indoor unit. Indoor units that are in a mode different to that of the VIP unit display the mode conflict error. If there is no unit with VIP address or the VIP unit is in standby, the outdoor units operate in voting priority mode. In voting priority mode, the outdoor units operate in whichever of heating and cooling modes is being requested by the larger number of indoor units.
4. **Heating only mode:** The outdoor units only operate in heating mode. Indoor units requesting heating operate in heating mode. Indoor units requesting cooling or in fan only mode display the mode conflict error.
5. **Cooling only mode:** The outdoor units only operate in cooling mode. Indoor units requesting cooling operate in cooling mode; indoor units in fan only mode operate in fan only mode. Indoor units requesting heating display the mode conflict error.

## 1.2.2 Silent time setting

### 1.2.2.1 Night silent time setting

Night silent mode is activated X hours after the peak daytime temperature, and is deactivated after Y hours, where X and Y are as specified in Table 4-1.2.

Table 4-1.2: Night silent time setting

Switch	Switch positions	Description	X	Y
 ENC5	0	Night silent time is 6h/10h (default)	6	10
	1	Night silent time is 6h/12h	6	12
	2	Night silent time is 8h/10h	8	10
	3	Night silent time is 8h/12h	8	12

Figure 4-1.2: Night silent mode example (default setting, 6h/10h)



## 1.2.2.2 Silent mode setting

In silent mode 1 / 2 / 3, the outdoor fan speed decreases gradually. In super silent mode 1 / 2 / 3 / 4 and night silent mode, not only the fan speed decreases gradually, but also the compressor frequency decreases gradually.

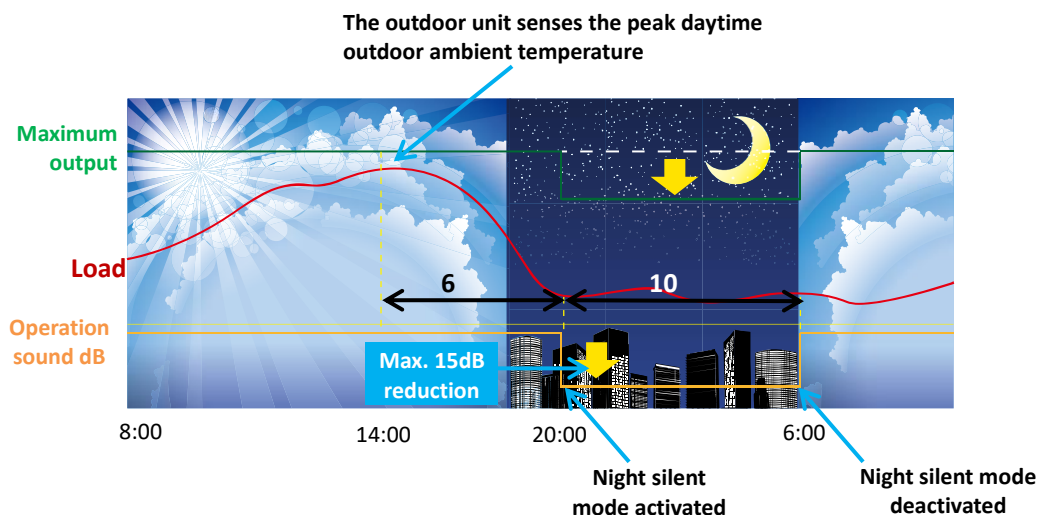
Table 4-1.3: Silent mode setting

Switch	Switch positions	Description
 ENC5	5	Silent mode 1 (only limit max. fan speed)
	6	Silent mode 2 (only limit max. fan speed)
	7	Silent mode 3 (only limit max. fan speed)
	8	Super silent mode 1 (limit max. fan speed and compressor frequency)
	9	Super silent mode 2 (limit max. fan speed and compressor frequency)
	A	Super silent mode 3 (limit max. fan speed and compressor frequency)
	B	Super silent mode 4 (limit max. fan speed and compressor frequency)

## 1.2.2.3 Maximum fan speed and capacity output control in different silent mode

Table 4-1.4: Maximum fan speed and capacity output control in different silent mode

ENC5 Switch positions	Description	Max. fan speed index <sup>1</sup>						Max. capacity output
		8-10HP	12HP	14-16HP	18-22HP	24-26HP	28-32HP	
0	Night silent time is 6h/10h (default)	28	28	28	22	28	28	100%
1	Night silent time is 6h/12h							
2	Night silent time is 8h/10h							
3	Night silent time is 8h/12h							
4	No silent mode	30	31	30	30	30	31	
5	Silent mode 1	28	28	28	27	28	28	
6	Silent mode 2	26	26	26	25	26	26	
7	Silent mode 3	24	24	24	23	24	24	
8	Super silent mode 1	28	28	28	22	28	28	80%
9	Super silent mode 2	27	27	27	21	27	27	70%
A	Super silent mode 3	26	26	26	20	26	26	60%
B	Super silent mode 4	25	25	25	19	25	25	50%

Notes:

1. Fan speed (rpm) for different fan speed index refers to Table 3-5.3 in Part 3, 5.6 "Outdoor Fan Control".
2. If the system pressure is over 3.5MPa, the system exits silent mode automatically.

# Part 5

# Electrical Components and Wiring Diagrams

1	Outdoor Unit Electric Control Box Layout .....	56
2	Outdoor Unit Main PCB.....	58
3	Wiring Diagrams.....	66



## 1 Outdoor Unit Electric Control Box Layout

8-16HP

Figure 5-1.1: 8-16HP top layer of electric control box

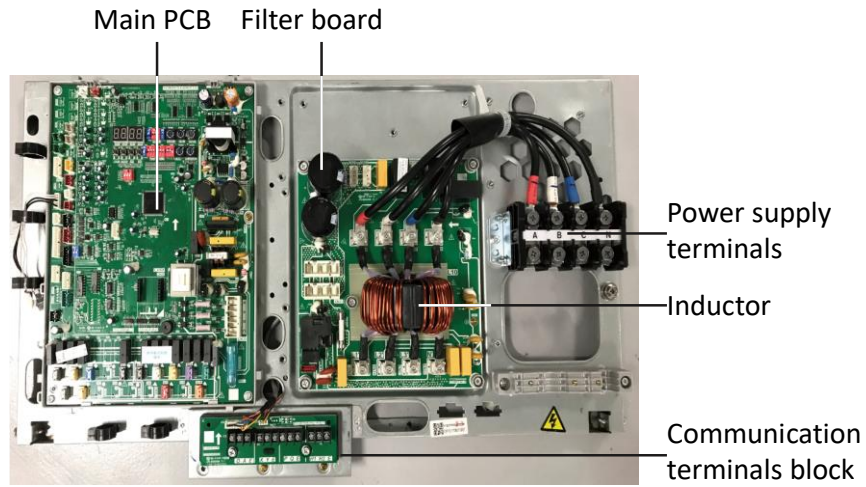

Figure 5-1.2: 8-16HP bottom layer of electric control box

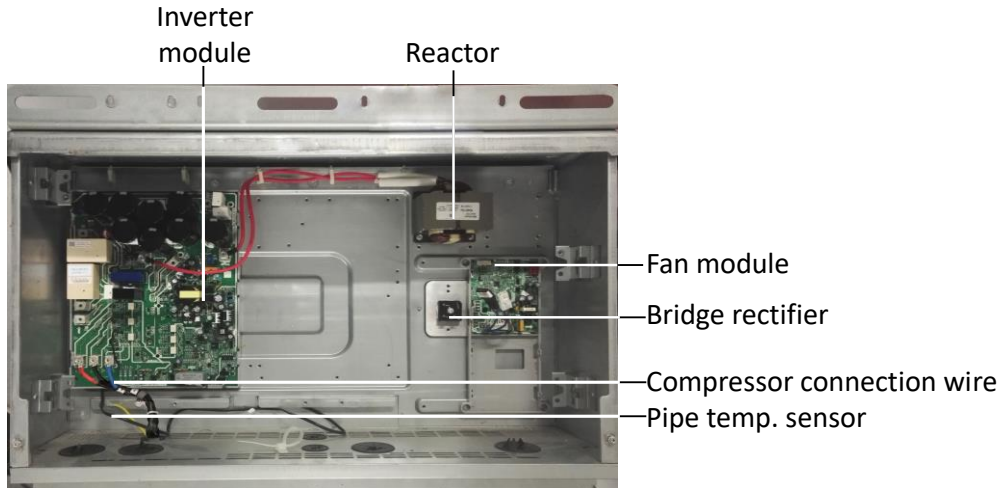

Figure 5-1.3: 18-32HP top layer of electric control box

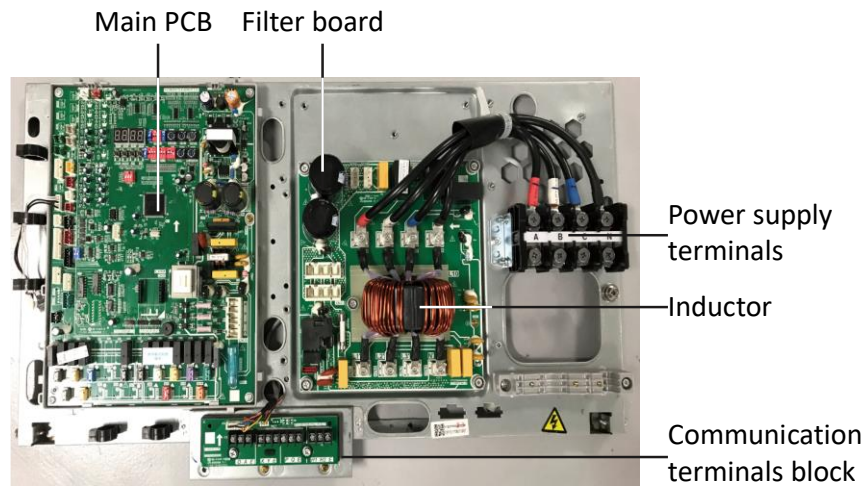
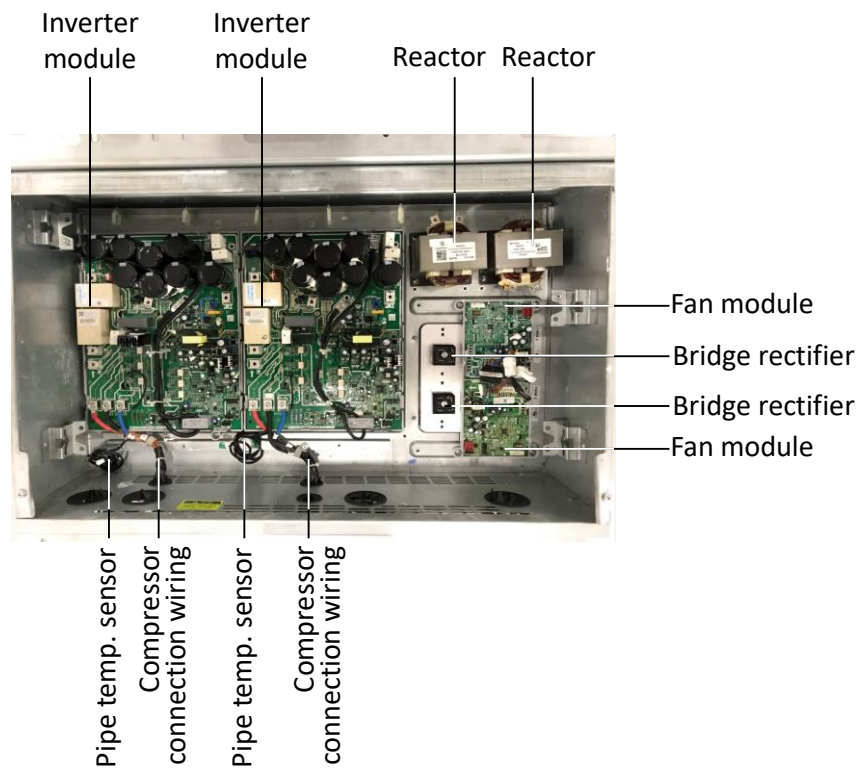

Figure 5-1.4: 18-32HP bottom layer of electric control box



## 2 Outdoor Unit Main PCB

### 2.1 Ports

Figure 5-2.1: Outdoor unit main PCB ports<sup>1</sup>

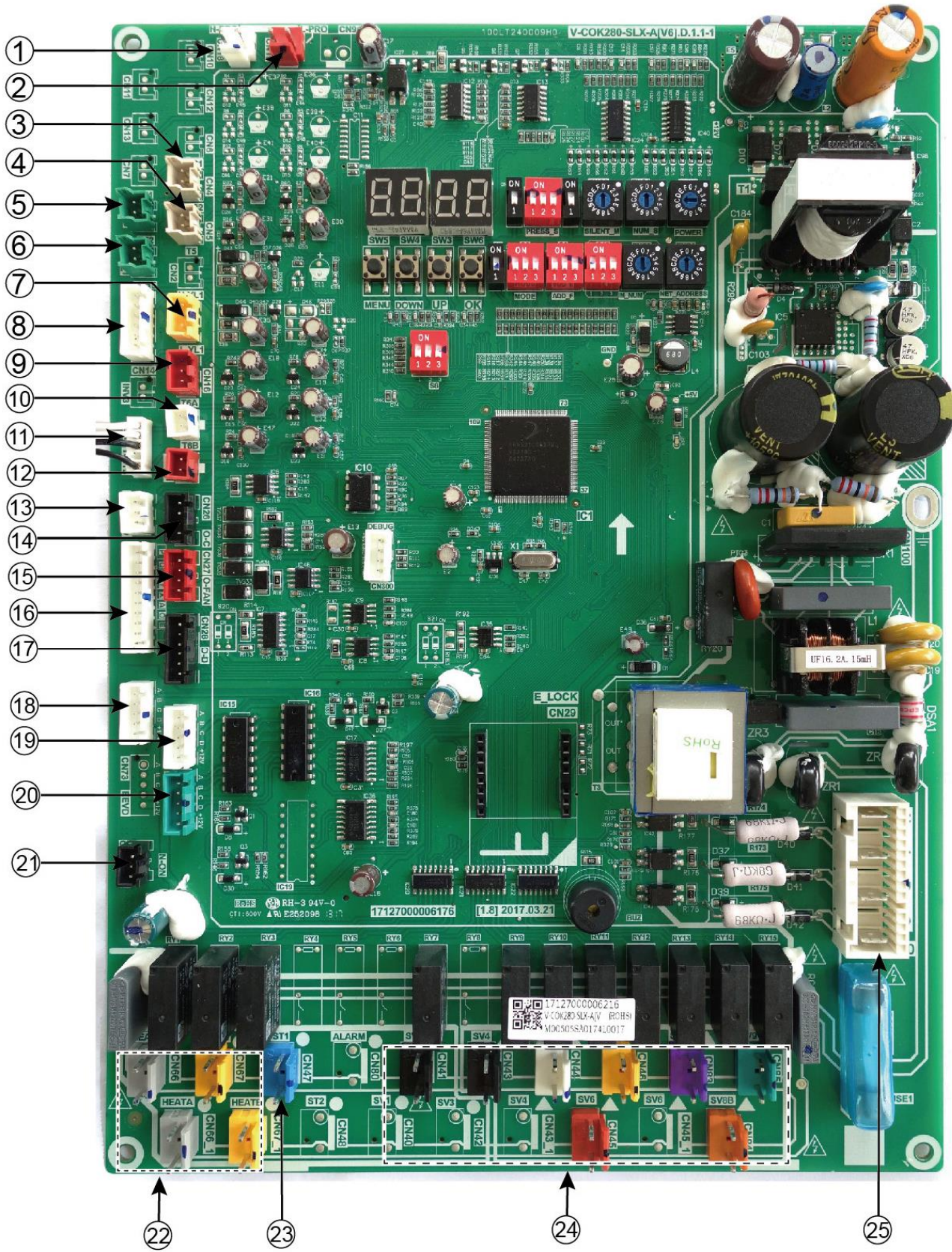

Notes:

1. Label descriptions are given in Table 5-2.1.

Table 5-2.1: Main PCB ports

Label in Figure 5-2.1	Port code	Content	Port voltage
1	CN18	High pressure switch and discharge temperature switch(es) connections	0V or 5V DC
2	CN19	Low pressure switch connection	0V or 5V DC
3	CN4	Compressor top temperature sensor (single compressor units) or compressor A compressor top temperature sensor (dual compressor units) connection	0-5V DC (varying)
4	CN5	Discharge pipe temperature sensor (single compressor units) or compressor B compressor top temperature sensor (dual compressor units) connection	0-5V DC (varying)
5	CN3	Inverter module temperature sensor A connection	0-5V DC (varying)
6	CN3_1	Inverter module temperature sensor B connection	0-5V DC (varying)
7	CN17	High pressure sensor connection	0-5V DC (varying)
8	CN15	Inverter compressor A and B current sensor connections	0-7.8V AC (varying)
9	CN16	Reserved	/
10	CN8	Plate heat exchanger inlet temperature sensor connection	0-5V DC (varying)
11	CN1	Outdoor ambient temperature sensor and outdoor heat exchanger temperature sensor connections	0-5V DC (varying)
12	CN8_1	Plate heat exchanger outlet temperature sensor connection	0-5V DC (varying)
13	CN20	Communication port to outdoor units	2.5-2.7V DC
14	CN26	Communication port to compressor drive board	2.5-2.7V DC
15	CN27	Communication port to fan drive board	2.5-2.7V DC
16	CN25	Communication port	2.5-2.7V DC
17	CN28	Reserved	/
18	CN71	EEVB drive port	0V or 12V DC
19	CN70	EEVA drive port	0V or 12V DC
20	CN72	EEVC drive port	0V or 12V DC
21	CN82	Control port of relay for AC filter board	0V or 12V DC
22	CN66-CN67	Power supply to compressor crankcase heater	220V AC
23	CN47	Four-way valve drive ports	220V AC
24	CN41-CN46; CN83-CN85	Solenoid valve drive ports	220V AC
25	CN30	Power input of main board	220V AC between A/B/C and N; 380V AC between A,B and C

## 2.2 Components

### 2.2.1 Layout

Figure 5-2.2: Outdoor unit main PCB components

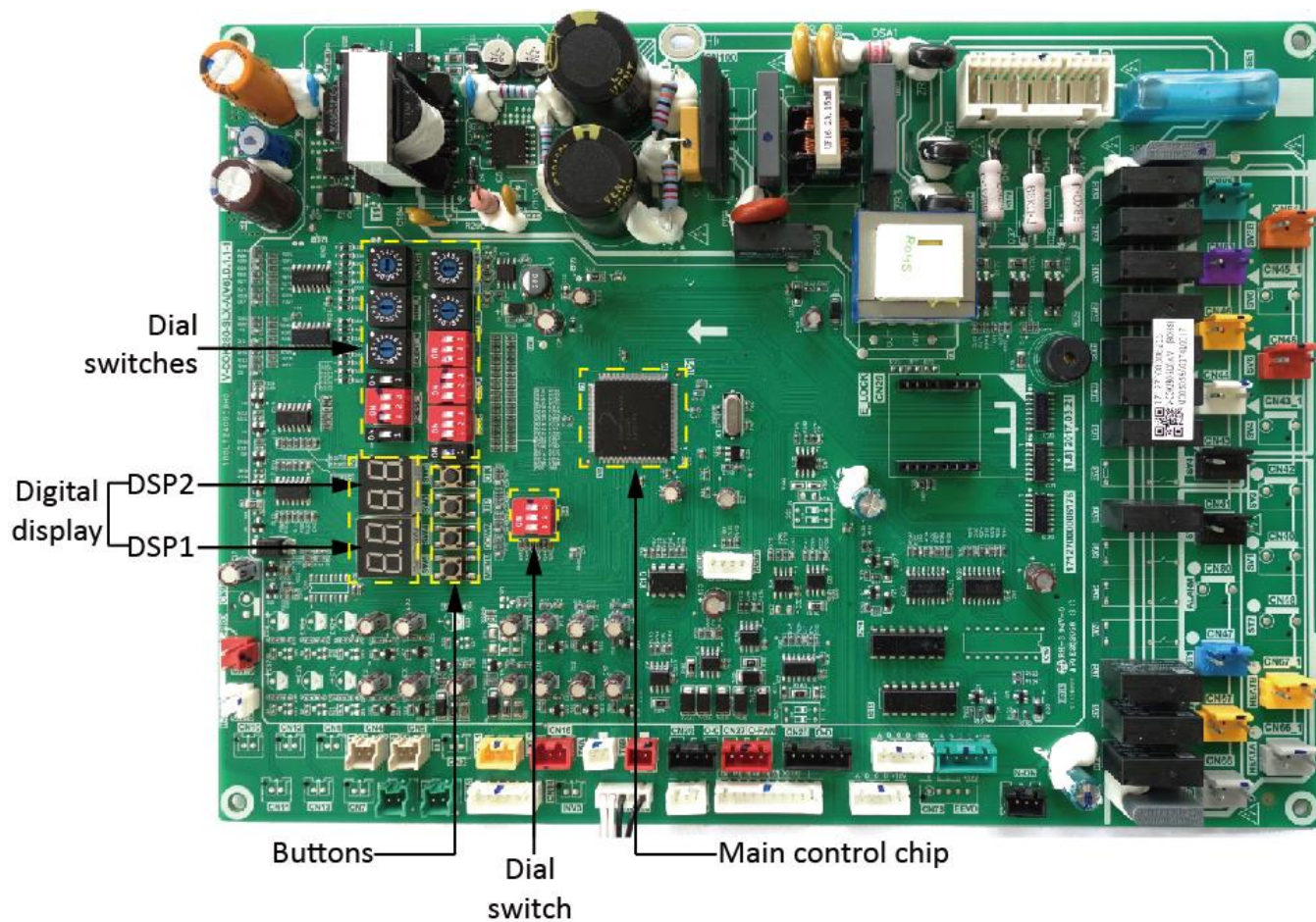

### 2.2.2 Function of buttons SW3 to SW6

Table 5-2.2: Function of buttons SW3 to SW6

Button	Function
SW3 (UP)	In menu mode: previous and next buttons for menu modes.
SW4 (DOWN)	Not in menu mode: previous and next buttons for system check information.
SW5 (MENU)	Enter / exit menu mode.
SW6 (OK)	Confirm to enter specified menu mode.



### 2.2.3 Menu mode

Only master unit has the full menu functions, slaves units only have error codes check and cleaning functions.

1. Long press SW5 "MENU" button for 5 seconds to enter menu mode, and the digital display displays "n1";
2. Press SW3 / SW4 "UP / DOWN" button to select the first level menu "n1", "n2", "n3", "n4" or "nb";
3. Press SW6 "OK" button to enter specified first level menu, for example, enter "n4" mode;
4. Press SW3 / SW4 "UP / DOWN" button to select the second level menu from "n41" to "n47";
5. Press SW6 "OK" button to enter specified second level menu, for example, enter "n43" mode;

#### Menu mode selection flowchart:

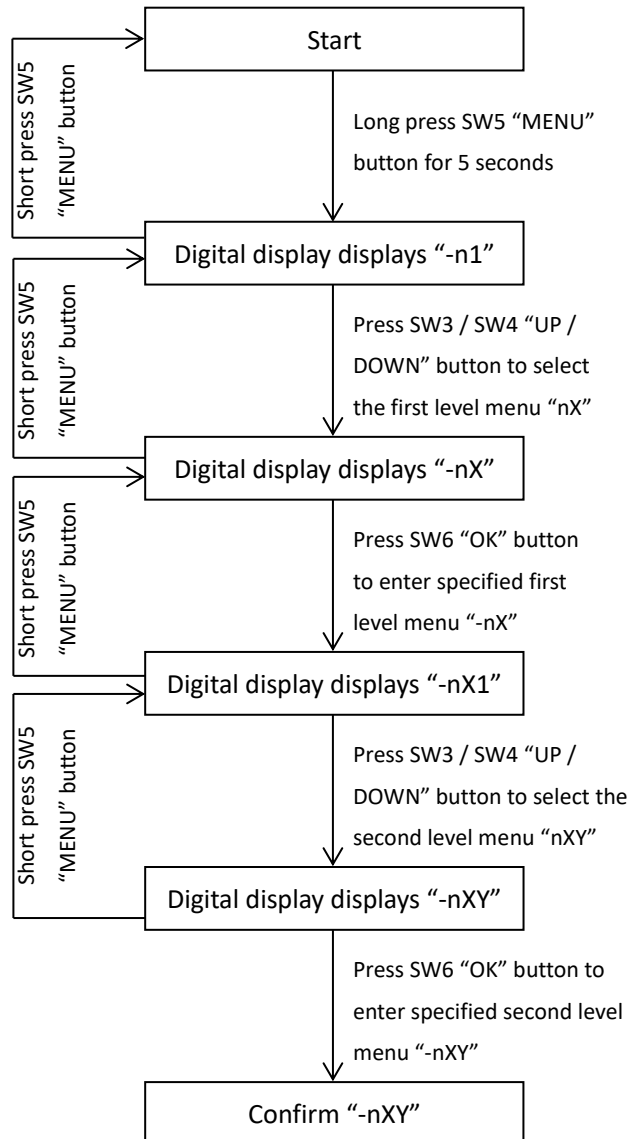

## Menu mode function:

Table 5-2.3: Menu mode function

Digital display content	Menu mode	Remarks
n14	Debug mode 1	Only available for the master unit (all indoor units running in cooling mode)
n15	Debug mode 2	Only available for the master unit (if all the indoor unit in the system are the 2nd generation indoor units, all the indoor units will run in heating mode. Once there is one or more old indoor unit in the system, all the indoor units will run in force cooling mode)
n16	Maintenance mode	Only available for the master unit, the system does not check the indoor units' number.
n24	Reserved	
n25	Reserved	
n26	Backup run	Only available for outdoor unit with two compressors. If one of the two compressors is fail, the other compressor will keep running for up to 4 days and then stop automatically.
n27	Vacuum mode	It is only used in maintenance process. The digital display displays "R006", all solenoid valves are open and EXVs are open to the maximum steps.
n31	History error codes	Display recent ten history error codes
n32	Cleaning history error codes	
n33	Reserved	
n34	Factory reset	Only available for the master unit
n41	Power limitation mode 1	Only available for the master unit, 100% capacity output
n42	Power limitation mode 2	Only available for the master unit, 90% capacity output
n43	Power limitation mode 3	Only available for the master unit, 80% capacity output
n44	Power limitation mode 4	Only available for the master unit, 70% capacity output
n45	Power limitation mode 5	Only available for the master unit, 60% capacity output
n46	Power limitation mode 6	Only available for the master unit, 50% capacity output
n47	Power limitation mode 7	Only available for the master unit, 40% capacity output
nb1	Fahrenheit degree setting (°F)	Only available for the master unit
nb2	Celsius degree setting (°C)	Only available for the master unit
nb3	Exit auto power save mode <sup>1</sup>	Only available for the master unit
nb4	Enter auto power save mode <sup>1</sup>	Only available for the master unit
nb5	Auto snow-blowing mode 1 (customized)	According to outdoor ambient temperature (T4), the outdoor fan(s) periodically stop for 15 minutes and run for 2 minute
nb6	Auto snow-blowing mode 2 (customized)	According to outdoor ambient temperature (T4), the outdoor fan(s) periodically stop for 30 minutes and run for 2 minute
nb7	Exit auto snow-blowing mode	
nb8	VIP address setting	The digital display will display "IdXX", "XX" stands for VIP address, use UP / DOWN button to change the VIP address and press OK button to confirm the specified VIP address.
nF1	Reserved	
nF2	Reserved	

Notes:

1. Auto power save mode means EMS mode, the evaporating temperature (in cooling) and condensing temperature (in heating) are automatically adjusted according to both indoor and outdoor temperature to maximize the comfort and energy efficiency. Exit auto power save mode, the evaporating temperature (in cooling) and condensing temperature (in heating) are fixed.

**How to exit specified menu mode:**

Table 5-2.4: Exit specified menu mode method:

Menu mode	Manual exit method	Automatic exit method	System restart
Debug mode 1 (2)	Long press SW6 "OK" button when the digital display is not in menu selection state	After running 120 minutes	Invalid
Maintenance mode	/	After running 60 minutes	Invalid
Backup run	/	After running 4 days or both two compressors are failed	Invalid
Vacuum mode	Long press SW6 "OK" button when the digital display is not in menu selection state	After running 8 hours	Invalid
Power limitation mode	Select power limitation mode 1 "n41"	/	Valid
Auto power save mode	Select "nb3"	/	Valid
Auto snow-blowing mode 1 (2)	Select "nb7"	/	Valid
VIP address setting	/	/	Valid
°F / °C setting	/	/	Valid

**2.2.4 UP / DOWN system check button**

Before pressing UP or DOWN button, allow the system to operate steadily for more than an hour. On pressing UP or DOWN button, the parameters listed in Table 5-2.5 will be displayed in sequence.

Table 5-2.5: System check

DSP1 content	Parameters displayed on DSP2	Remarks
0.--	Unit address	Master unit: 0; slave units: 1, 2, 3
1.--	Unit capacity	Refer to Note 1
2.--	Number of outdoor units	Displayed on master unit PCB only
3.--	Number of indoor units as set on PCB	Displayed on master unit PCB only
4.--	Total capacity of outdoor unit	Only available for master unit, displayed on slave units has no sense
5.--	Total capacity requirement of indoor units	Displayed on master unit PCB only
6.--	Total corrected capacity requirement of indoor units	Displayed on master unit PCB only
7.--	Operating mode	Refer to Note 2
8.--	Outdoor unit actual operating capacity	
9.--	Fan A speed index	Refer to Note 3
10.--	Fan B speed index	Refer to Note 3
11.--	Indoor heat exchanger pipe (T2/T2B) temperature (°C)	Actual value = value displayed
12.--	Main heat exchanger pipe (T3) temperature (°C)	Actual value = value displayed
13.--	Outdoor ambient (T4) temperature (°C)	Actual value = value displayed
14.--	Plate heat exchanger cooling refrigerant inlet (T6A) temperature (°C)	Actual value = value displayed
15.--	Plate heat exchanger cooling refrigerant outlet (T6B) temperature (°C)	Actual value = value displayed
16.--	Inverter compressor A discharge temperature (°C)	Actual value = value displayed
17.--	Inverter compressor B discharge temperature (°C)	Actual value = value displayed
18.--	Inverter module A heatsink temperature (°C)	Actual value = value displayed
19.--	Inverter module B heatsink temperature (°C)	Actual value = value displayed
20.--	Plate heat exchanger cooling refrigerant outlet temperature minus inlet temperature (°C)	Actual value = value displayed
21.--	Discharge superheat degree (°C)	Actual value = value displayed
22.--	Inverter compressor A current (A)	Actual value = value displayed
23.--	Inverter compressor B current (A)	Actual value = value displayed
24.--	EXVA position	Refer to Note 4
25.--	EXVB position	Refer to Note 4
26.--	EXVC position	Refer to Note 4
27.--	Compressor discharge pressure (MPa)	Actual value = value displayed × 0.1
28.--	Reserved	
29.--	Number of indoor units currently in communication with master unit	Actual value = value displayed
30.--	Number of indoor units currently operating	Displayed on master unit PCB only
31.--	Priority mode	Refer to Note 5
32.--	Silent mode	Refer to Note 6
33.--	Static pressure mode	Refer to Note 7

Table continued on next page ...



Table 5-2.5: System check (continued)

DSP1 content	Parameters displayed on DSP2	Remarks
34.--	Reserved	
35.--	Reserved	
36.--	DC voltage A	Actual value = value displayed × 10
37.--	DC voltage B	Actual value = value displayed × 10
38.--	Reserved	
39.--	Address of VIP indoor unit	
40.--	Reserved	
41.--	Reserved	
42.--	Refrigerant quantity	Refer to Note 8
43.--	Reserved	
44.--	Power mode	Refer to Note 9
45.--	Most recent error or protection code	"--" is displayed if no error or protection events have occurred since start-up
-- --	--	End

- Notes:
- Outdoor unit capacity setting:
    - 0: 8HP; 1: 10HP; 2: 12HP; 3: 14HP; 4: 16HP; 5: 18HP; 6: 20HP; 7: 22HP; 8: 24HP; 9: 26HP; A: 28HP; B: 30HP; C: 32HP.
  - Operating mode:
    - 0: off; 2: cooling; 3: heating; 4: forced cooling.
  - The fan speed index is related to the fan speed in rpm and can take any integer value in the range 1 (slowest) to 35 (fastest).
  - 480P: steps = value displayed × 4; 3000P: steps = value displayed × 24.
  - Priority mode:
    - 0: auto priority; 1: cooling priority; 2: VIP priority or voting priority; 3: heating only; 4: cooling only.
  - Silent mode:
    - 0: night silent time 6h/10h; 1: night silent time 6h/12h; 2: night silent time 8h/10h; 3: night silent time 8h/12h; 4: no silent mode; 5: silent mode 1; 6: silent mode 2; 7: silent mode 3; 8: super silent mode 1; 9: super silent mode 2; 10: super silent mode 3; 11: super silent mode 4.
  - Static pressure mode:
    - 0: standard static pressure; 1: low static pressure; 2: medium static pressure; 3: high static pressure; 4: super high static pressure.
  - Refrigerant quantity:
    - 0: normal; 1: slightly excessive; 2: significantly excessive; 3: slightly insufficient; 4: significantly insufficient; 5: critically insufficient.
  - Power mode:
    - 0: 100% capacity output; 1: 90% capacity output; 2: 80% capacity output; 3: 70% capacity output; 4: 60% capacity output; 5: 50% capacity output; 6: 40% capacity output; 10: auto power save mode, 100% capacity output; 11: auto power save mode, 90% capacity output; 12: auto power save mode, 80% capacity output; 13: auto power save mode, 70% capacity output; 14: auto power save mode, 60% capacity output; 15: auto power save mode, 50% capacity output; 16: auto power save mode, 40% capacity output;

## 2.2.5 Digital display output

Table 5-2.6: Digital display output in different operating states

Outdoor unit state		Parameters displayed on DSP1	Parameters displayed on DSP2
Standby		Unit's address	The number of indoor units in communication with the outdoor units
Normal operation	For single compressor units	--	Running speed of the compressor in rotations per second
	For dual compressor units	Running speed of compressor B in rotations per second	Running speed of compressor A in rotations per second
Error or protection		-- or placeholder	Error or protection code
In menu mode		Refer to Table 5-2.3	Refer to Table 5-2.3
System check		Refer to Table 5-2.5	Refer to Table 5-2.5

DSP1

DSP2

### 3 Compressor Inverter Module

#### 3.1.1 Layout

Figure 5-3.1: Compressor inverter module components

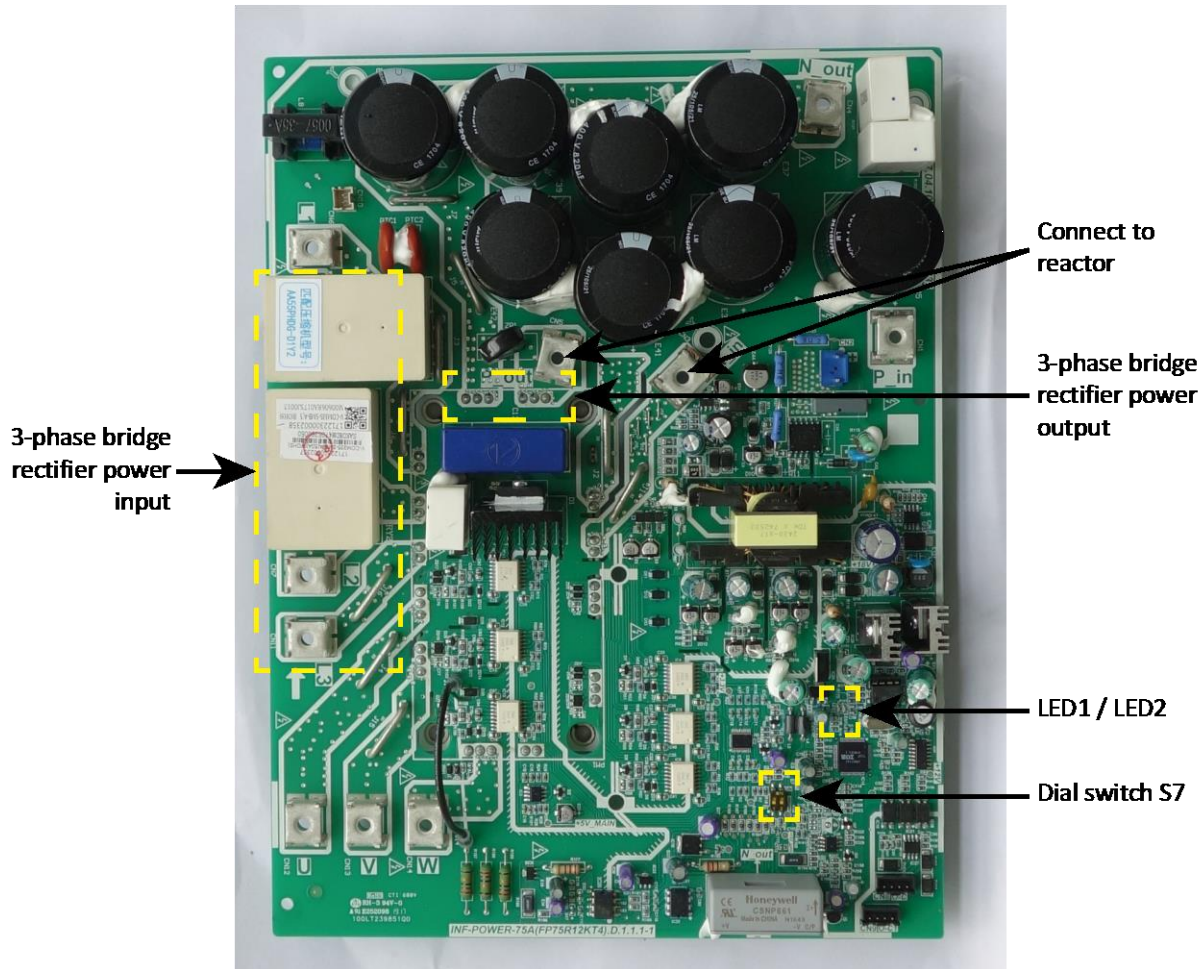

#### 3.1.2 LED indicators LED1 and LED2

Table 5-3.1: LED indicators LED1 and LED2

Indicator	LED indicator function and status	
LED 1	Inverter module operating indicator. Continuously on if the compressor is running normally and flashing if an inverter module error has occurred <sup>1</sup> .	
LED 2	Inverter module error indicator. Continuously on if an inverter module error has occurred <sup>1</sup> .	

Note:

1. If an inverter module error occurs, refer to Part 6, “Xh4 Troubleshooting”. The error code is displayed on the digital display.

#### 3.1.3 Dial switch S7 setting

Dial switch S7 is used to set compressor inverter module A/B address. The compressor inverter module A/B location refers to the wiring diagram.

S7 on inverter module	Inverter module address
	0 for compressor inverter module A
	1 for compressor inverter module B

# Super X VRF 50/60Hz

## 4 Wiring Diagrams

### 8-28HP

Figure 5-4.1: 8-28HP wiring diagram

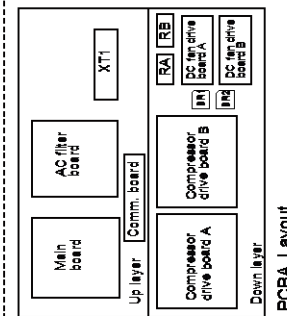
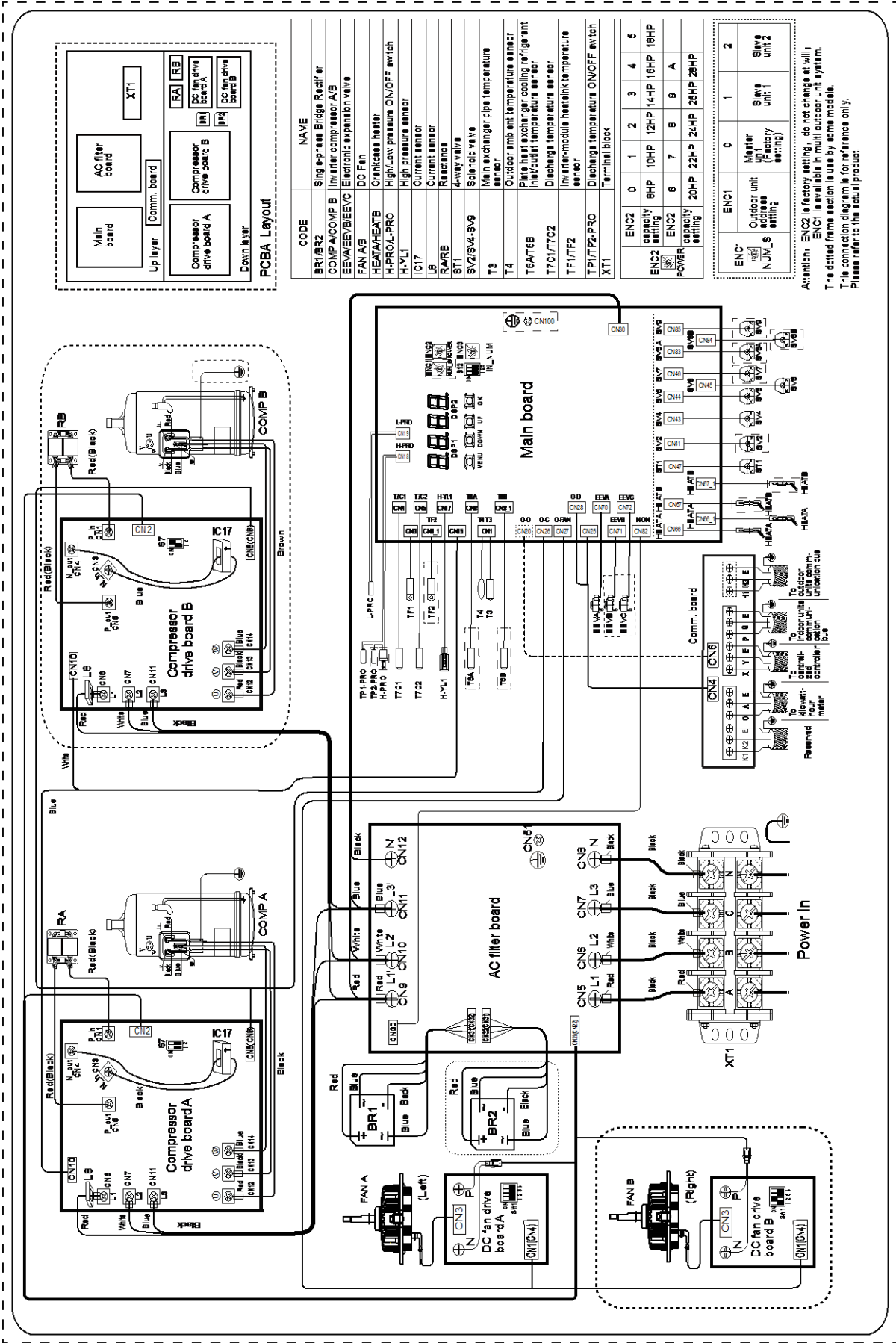

CODE	NAME
BR1/BR2	Single-phase Bridge Rectifier
COMP/COMP B	Inverter compressor A/B
E2V4E2V5E2V6	Electronic expansion valve
FAN A/B	DC Fan
HEAT/HEAT B	Crankcase heater
H-PRO/L-PRO	High/Low pressure ON/OFF switch
H-Y/L	High pressure sensor
IC17	Current sensor
LB	Current sensor
RA/RB	Resistance
ST1	4-way valve
SV2/SV4-SV6	Solenoid valve
T3	Main exchanger pipe temperature sensor
T4	Outdoor ambient temperature sensor
T5	Plat heat exchanger cooling refrigerant in/outlet temperature sensor
T6/T7/T8	Discharge temperature sensor
T9	Inverter-module heatlink temperature sensor
TF1/TF2-PRO	Discharge temperature ON/OFF switch
XT1	Terminal block

ENC2	0	1	2	3	4	5
capacity	8HP	10HP	12HP	14HP	16HP	18HP
ENC2	6	7	8	9	A	
POWER	capacity setting	20HP	22HP	24HP	26HP	28HP

ENC1	0	1	2
Outdoor unit address setting		Slave unit 1	Slave unit 2
Master unit address setting (Factory setting)		Slave unit 1	Slave unit 2

Attention: ENC2 is factory setting, do not change it will. ENC1 is available in multi outdoor unit system. The dotted frame section is for reference only. Please refer to the actual product.

30-32HP

Figure 5-4.2: 30-32HP wiring diagram

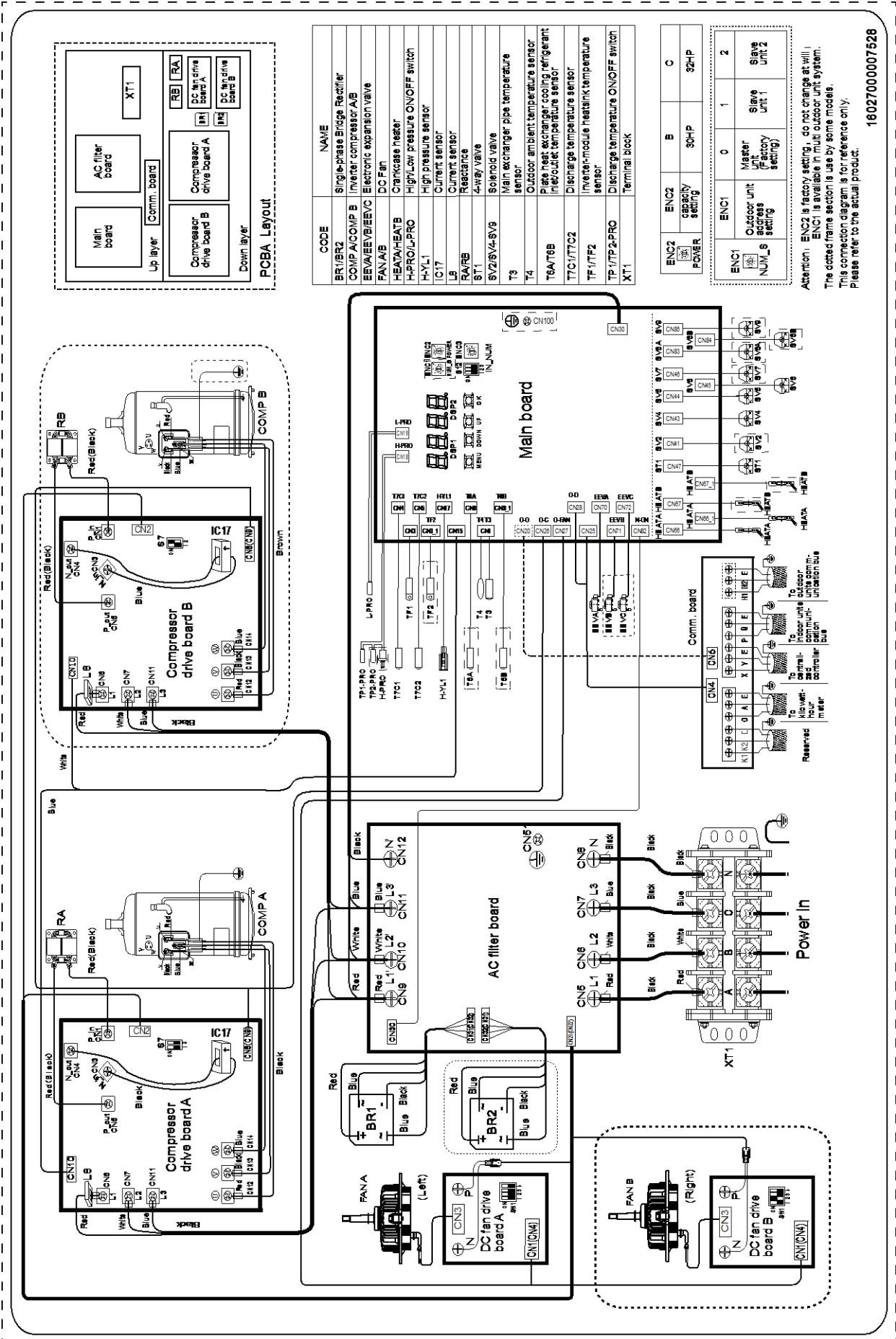



# Part 6

# Diagnosis and Troubleshooting

1	Error Code Table .....	70
2	Troubleshooting .....	71
3	Appendix to Part 6 .....	131

## 1 Error Code Table

Table 6-1.1: Error code table

Error code <sup>1</sup>	Content	Remarks	Manual re-start required <sup>2</sup>
E0	Communication error between outdoor units	Only displayed on the slave unit with the error	No
E1	Phase sequence error	Displayed on the unit with the error	Yes
E2	Communication error between indoor and master unit	Only displayed on the master unit	No
E4	Outdoor heat exchanger temperature sensor (T3) error or outdoor ambient temperature sensor (T4) error	Displayed on the unit with the error	No
E5	Abnormal power supply voltage	Displayed on the unit with the error	No
E7	Compressor top or discharge pipe temperature sensor (T7C1/2) error	Displayed on the unit with the error	Yes
E8	Outdoor unit address error	Displayed on the unit with the error	Yes
xE9	EEPROM mismatch	Displayed on the unit with the error	Yes
xF1	DC bus voltage error	Displayed on the unit with the error	No
F3	Plate heat exchanger cooling refrigerant outlet temperature sensor (T6B) error	Displayed on the unit with the error	No
F5	Plate heat exchanger cooling refrigerant inlet temperature sensor (T6A) error	Displayed on the unit with the error	No
F6	Electronic expansion valve connection error	Displayed on the unit with the error Refer to Note 3	Yes
xH0	Communication error between main control chip and inverter driver chip	Displayed on the unit with the error	No
H2	Number of slave units detected by master unit has decreased	Only displayed on the master unit	No
H3	Number of slave units detected by master unit has increased	Only displayed on the master unit	No
xH4	Inverter module protection	Displayed on the unit with the error	Yes
H5	P2 protection appears three times in 60 minutes	Displayed on the unit with the error	Yes
H6	P4 protection appears three times in 100 minutes	Displayed on the unit with the error	Yes
H7	Number of indoor units detected by master unit not same as number set on main PCB	Only displayed on the master unit	No
H8	High pressure sensor error	Displayed on the unit with the error	No
H9	P9 protection appears ten times in 120 minutes	Displayed on the unit with the error	Yes
yHd	Slave unit malfunction	Only displayed on the master unit	No
C7	PL protection appears three times in 100 minutes	Displayed on the unit with the error	Yes
P1	Discharge pipe high pressure protection	Displayed on the unit with the error	No
P2	Suction pipe low pressure protection	Displayed on the unit with the error	No
xP3	Compressor current protection	Displayed on the unit with the error	No
P4	Discharge temperature protection	Displayed on the unit with the error	No
P5	Outdoor heat exchanger temperature protection	Displayed on the unit with the error	No
P9	Fan module protection	Displayed on the unit with the error	No

Table continued on next page ...

Table 6-1.1: Error code table (continued)

Error code <sup>1</sup>	Content	Remarks	Manual re-start required <sup>2</sup>
PL	Inverter module temperature protection	Displayed on the unit with the error	No
PP	Compressor discharge insufficient superheat protection	Displayed on the unit with the error	No
xL0	Inverter module protection	Displayed on the unit with the error	Yes
xL1	DC bus low voltage protection	Displayed on the unit with the error	Yes
xL2	DC bus high voltage protection	Displayed on the unit with the error	Yes
xL4	MCE error	Displayed on the unit with the error	Yes
xL5	Zero speed protection	Displayed on the unit with the error	Yes
xL7	Phase sequence error	Displayed on the unit with the error	Yes
xL8	Compressor frequency variation greater than 15Hz within one second protection	Displayed on the unit with the error	Yes
xL9	Actual compressor frequency differs from target frequency by more than 15Hz protection	Displayed on the unit with the error	Yes

## Notes:

- 'x' is a placeholder for the compressor system (compressor and related electrical components), with 1 representing compressor system A and 2 representing compressor system B. 'y' is a placeholder for the address (1 or 2) of the slave unit with the error.
- For some error codes, a manual restart is required before the system can resume operation.
- Once the EXV has been connected properly, the error code will flash to indicate that the connection has been re-established. A manual restart is then required before the system can resume operation.

## 2 Troubleshooting

### 2.1 Warning

#### Warning



- All electrical work must be carried out by competent and suitably qualified, certified and accredited professionals and in accordance with all applicable legislation (all national, local and other laws, standards, codes, rules, regulations and other legislation that apply in a given situation).
- Power-off the outdoor units before connecting or disconnecting any connections or wiring, otherwise electric shock (which can cause physical injury or death) may occur or damage to components may occur.



## Super X VRF 50/60Hz

### 2.2 E0: Communication error between outdoor units

#### 2.2.1 Digital display output

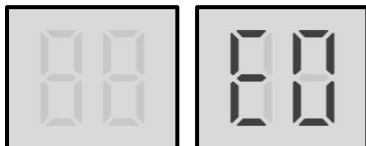

#### 2.2.2 Description

- Communication error between outdoor units.
- All units stop running.
- Error code is only displayed on the slave unit with the error.

#### 2.2.3 Trigger / recover condition

- Trigger condition: Slave unit cannot receive signal from master unit for 60s.
- Recover condition: Slave unit can receive signal from master unit.
- Reset method: Resume automatically.

#### 2.2.4 Possible causes

- Incorrect outdoor unit address setting.
- Communication wires between outdoor units not connected properly.
- Loosened wiring within electric control box.
- Damaged main PCB or electric control box communication terminals block.

2.2.5 Procedure

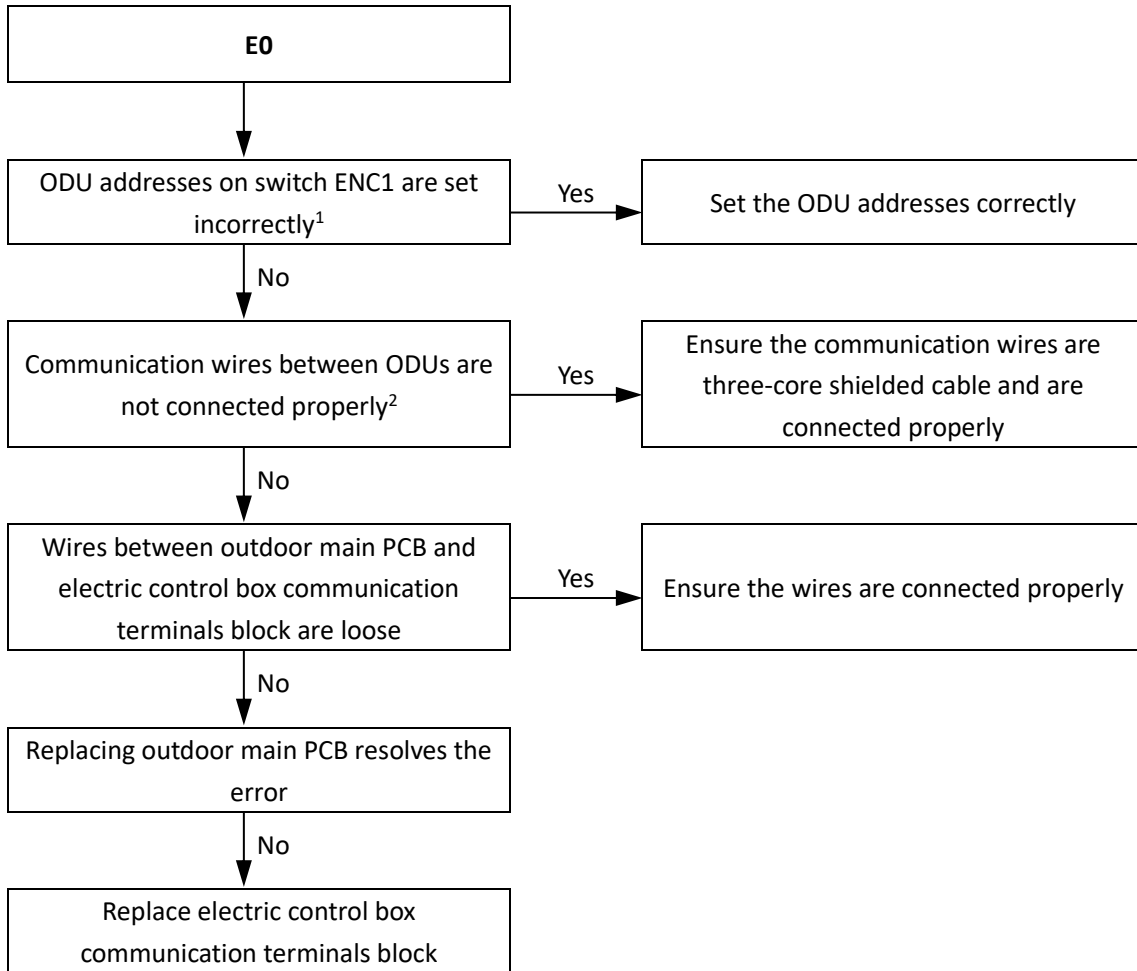

Notes:

1. The master unit address should be set as 0, slave units addresses should be set from 1 to 3, and the addresses should not be repeated within one system.
2. All the wires for H1, H2, E connections should be three-core shielded cable, the wiring should be connected according to polarity (H1 to H1, etc), the wiring should not be open or short circuited.

## Super X VRF 50/60Hz

### 2.3 E1: Phase sequence error

#### 2.3.1 Digital display output

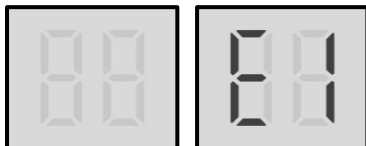

#### 2.3.2 Description

- Phase sequence error.
- All units stop running.
- Error code is only displayed on the unit with the error.

#### 2.3.3 Trigger / recover condition

- Trigger condition: Wrong phase connection for 1.6s or phase missing for 48s.
- Recover condition: Correct phase connection.
- Reset method: Manually restart.

#### 2.3.4 Possible causes

- Power supply phases not connected in correct sequence.
- Power supply terminals loose.
- Power supply abnormal.
- Main PCB damaged.

## 2.3.5 Procedure

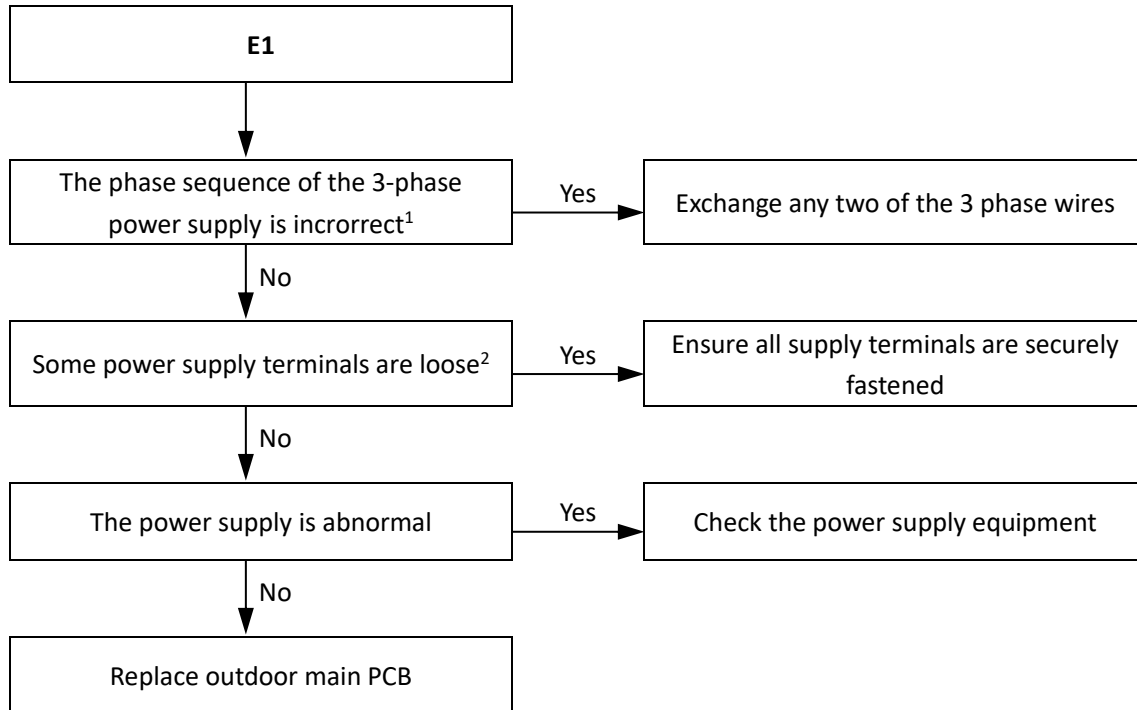

## Notes:

1. The A, B, C terminals of the 3-phase power supply should match compressor phase sequence requirements. If the phase sequence is inverted, the compressor will operate inversely. If the wiring connection of each outdoor unit is in A, B, C phase sequence, and multiple units are connected, the current difference between C phase and A, B phases will be very large as the power supply load of each outdoor unit will be on C phase. This can easily lead to tripped circuits and terminal wiring burnout. Therefore if multiple units are to be used, the phase sequence should be staggered, so that the current is distributed among the three phases equally.
2. Loose power supply terminals can cause the compressors to operate abnormally and compressor current to be very large.

## Super X VRF 50/60Hz

### 2.4 E2: Communication error between indoor and master unit

#### 2.4.1 Digital display output

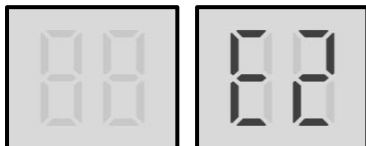

#### 2.4.2 Description

- Communication error between indoor and master unit.
- All units stop running.
- Error code is only displayed on the master unit.

#### 2.4.3 Trigger / recover condition

- Trigger condition: Indoor units and outdoor units cannot communicate for 2 minutes after the system power on 20 minutes.
- Recover condition: Communication goes back to normal.
- Reset method: Resume automatically.

#### 2.4.4 Possible causes

- Communication wires between indoor and outdoor units not connected properly.
- Indoor unit power supply abnormal.
- Loosened wiring within electric control box.
- Interference from high voltage wires or other sources of electromagnetic radiation.
- Communication wire too long.
- Damaged main PCB or electric control box communication terminals block.

## 2.4.5 Procedure

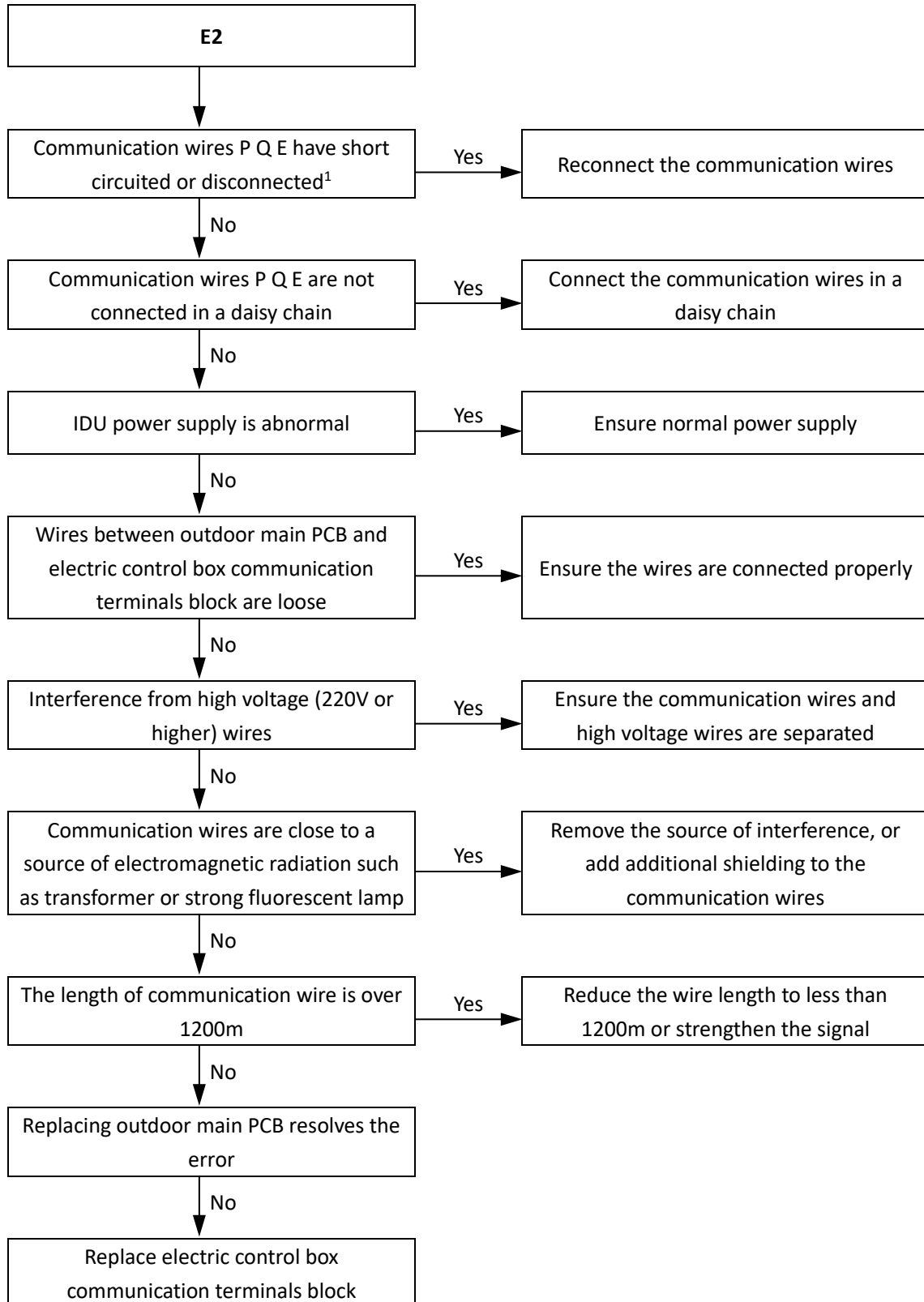

## Notes:

1. Measure the resistance among P, Q and E. The normal resistance between P and Q is 120Ω, between P and E is infinite, between Q and E is infinite.

## Super X VRF 50/60Hz

### 2.5 E4: Temperature sensor (T3/T4) error

#### 2.5.1 Digital display output

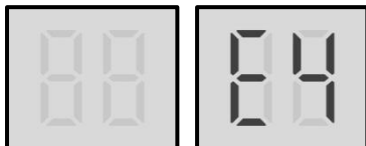

#### 2.5.2 Description

- Outdoor heat exchanger temperature sensor (T3) error or outdoor ambient temperature sensor (T4) error.
- All units stop running.
- Error code is only displayed on the unit with the error.

#### 2.5.3 Trigger / recover condition

- Trigger condition: The main control board cannot receive the feedback signal of temperature sensor T3 or T4.
- Recover condition: The main control board can receive the feedback signal of temperature sensor T3 or T4.
- Reset method: Resume automatically.

#### 2.5.4 Possible causes

- Temperature sensor not connected properly or has malfunctioned.
- Damaged main PCB.

## 2.5.5 Procedure

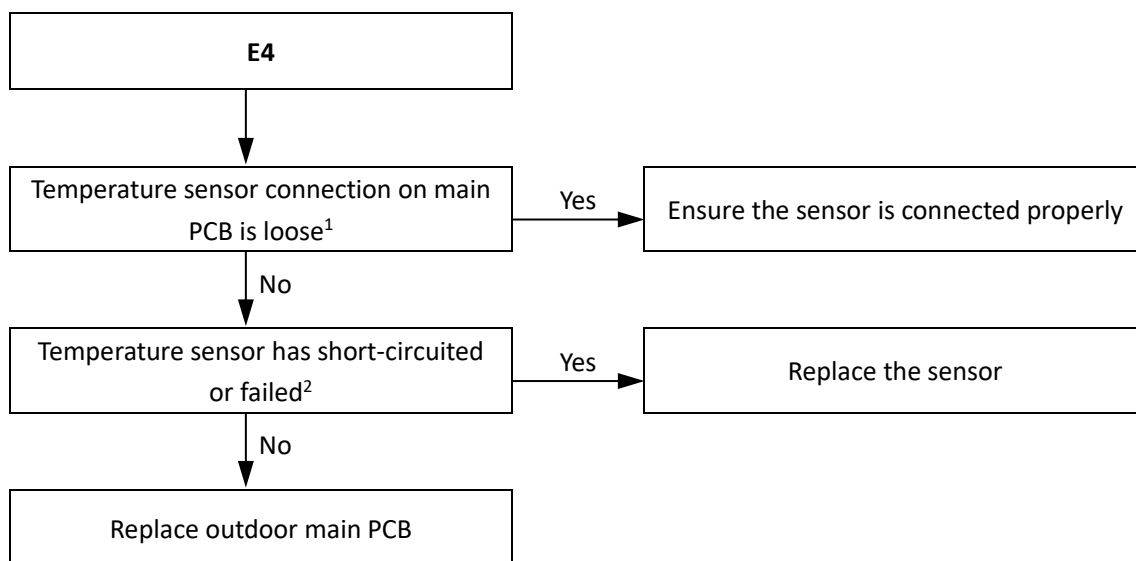

## Notes:

1. Outdoor ambient temperature sensor (T4) and heat exchanger temperature sensor (T3) connection is port CN1 on the main PCB (labeled 11 in Figure 5-2.1 in Part 5, 2.1 "Ports").
2. Measure sensor resistance. If the resistance is too low, the sensor has short-circuited. If the resistance is not consistent with the sensor's resistance characteristics table, the sensor has failed. Refer to Table 6-3.1 in Part 6, 3.1 "Temperature Sensor Resistance Characteristics".



## Super X VRF 50/60Hz

### 2.6 E5: Abnormal power supply voltage

#### 2.6.1 Digital display output

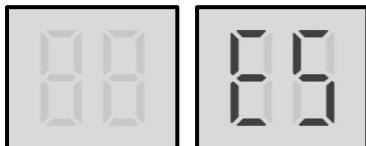

#### 2.6.2 Description

- Abnormal power supply voltage.
- All units stop running.
- Error code is only displayed on the unit with the error.

#### 2.6.3 Trigger / recover condition

- Trigger condition: Outdoor unit power supply phase voltage < 165V.
- Recover condition: Outdoor unit power supply phase voltage is > 180V.
- Reset method: Resume automatically.

#### 2.6.4 Possible causes

- Outdoor unit power supply voltage is abnormal or a phase is missing.
- Loosened wiring within electric control box.
- High voltage circuit error.
- Main PCB damaged.

2.6.5 Procedure

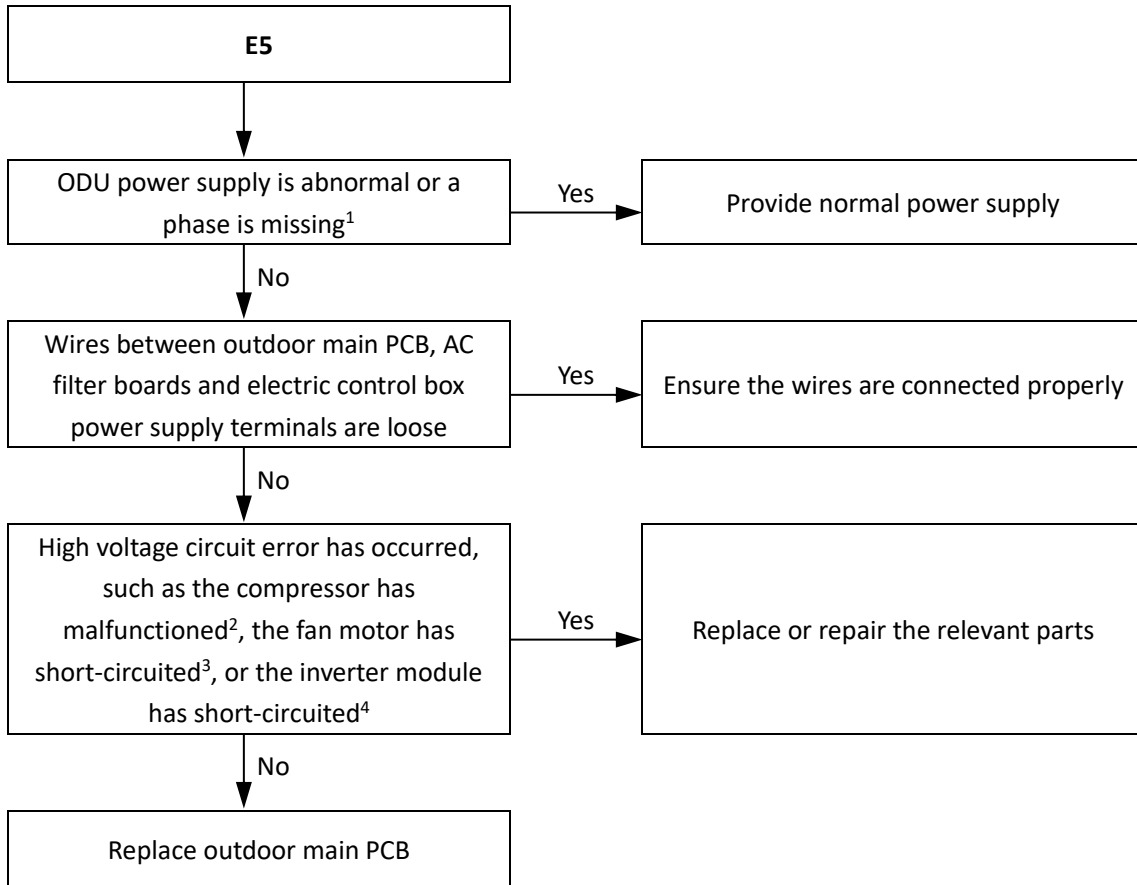

Notes:

1. The normal voltage between A and N, B and N, and C and N is 198-242V.
2. The normal resistances of the inverter compressor are 0.7-1.5Ω among U V W and infinite between each of U V W and ground. If any of the resistances differ from these specifications, the compressor has malfunctioned.
3. The normal resistances of the fan motor coil among U V W are less than 10Ω. If a measured resistance is 0Ω, the fan motor has short-circuited.
4. Set a multi-meter to buzzer mode and test any two terminals of P N U V W of the inverter module. If the buzzer sounds, the inverter module has short-circuited.

Figure 6-2.1: Inverter module terminals



## Super X VRF 50/60Hz

### 2.7 E7: Temperature sensor (T7C1/2) error

#### 2.7.1 Digital display output

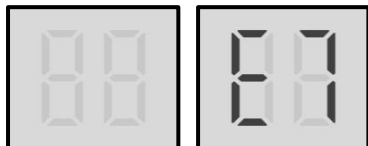

#### 2.7.2 Description

- A compressor top temperature sensor or discharge pipe temperature sensor (T7C1/2) error.
- All units stop running.
- Error code is only displayed on the unit with the error.

#### 2.7.3 Trigger / recover condition

- Trigger condition: Discharge pressure  $\geq$  3MPa and discharge temperature  $<$  15°C for 2 minutes.
- Recover condition: Discharge pressure and temperature go back to normal.
- Reset method: Manually restart.

#### 2.7.4 Possible causes

- Temperature sensor not connected properly or has malfunctioned.
- Damaged main PCB.

## 2.7.5 Procedure

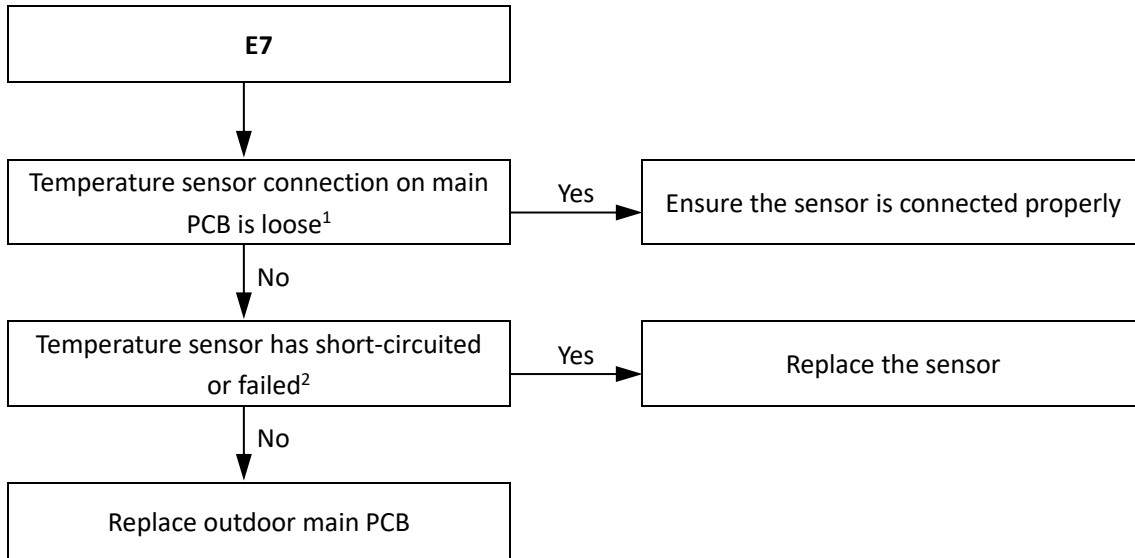

## Notes:

1. Compressor top temperature sensor and discharge pipe temperature sensor connections are ports CN4 and CN5 on the main PCB (labeled 3 and 4, respectively, in Figure 5-2.1 in Part 5, 2.1 "Ports").
2. Measure sensor resistance. If the resistance is too low, the sensor has short-circuited. If the resistance is not consistent with the sensor's resistance characteristics table, the sensor has failed. Refer to Table 6-3.2 in Part 6, 3.1 "Temperature Sensor Resistance Characteristics".

## Super X VRF 50/60Hz

### 2.8 E8: Outdoor unit address error

#### 2.8.1 Digital display output

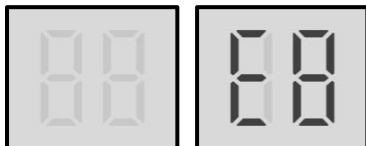

#### 2.8.2 Description

- Outdoor unit address error.
- All units stop running.
- Error code is only displayed on the unit with the error.

#### 2.8.3 Trigger / recover condition

- Trigger condition: Outdoor unit address is set more than 3.
- Recover condition: Outdoor unit addresses are set from 0 to 3.
- Reset method: Manually restart.

#### 2.8.4 Possible causes

- Invalid outdoor unit address.
- Main PCB damaged.

## 2.8.5 Procedure

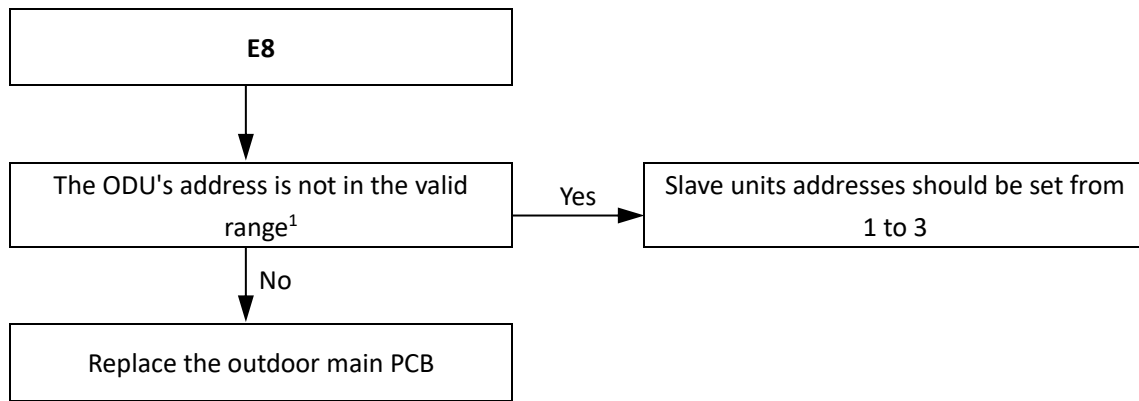

## Notes:

1. The master unit address should be set as 0, slave units addresses should be set from 1 to 3, and the addresses should not be repeated within one system.

## Super X VRF 50/60Hz

### 2.9 xE9: EEPROM mismatch

#### 2.9.1 Digital display output

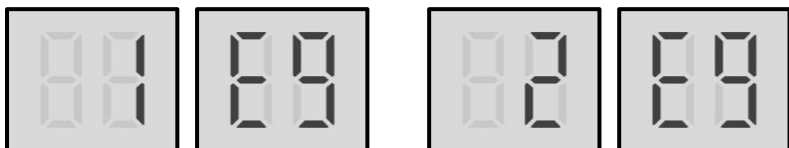

In the error code, 'x' is a placeholder for the compressor system (compressor and related electrical components), with 1 representing compressor system A and 2 representing compressor system B.

#### 2.9.2 Description

- 1E9 indicates a compressor A EEPROM mismatch.
- 2E9 indicates a compressor B EEPROM mismatch.
- All units stop running.
- Error code is only displayed on the unit with the error.

#### 2.9.3 Trigger / recover condition

- Trigger condition: Compressor drive parameter is mismatch.
- Recover condition: Compressor drive parameter is match.
- Reset method: Manually restart.

#### 2.9.4 Possible causes

- Outdoor unit was powered on immediately after being powered off.
- Main PCB damaged.

## 2.9.5 Procedure

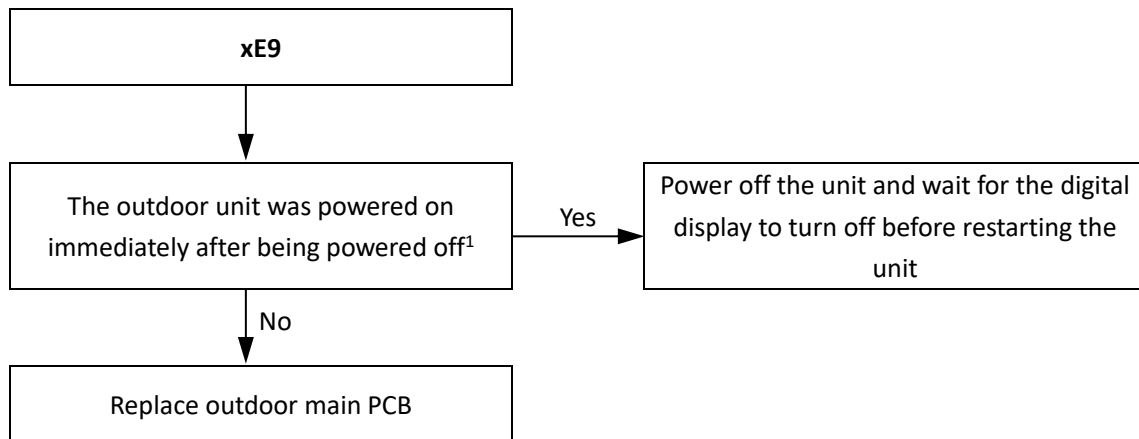

## Notes:

1. When performing a manual restart of an outdoor unit, once the unit has been powered off it should not be powered on again until the digital display has turned off.



## Super X VRF 50/60Hz

### 2.10 xF1: DC bus voltage error

#### 2.10.1 Digital display output

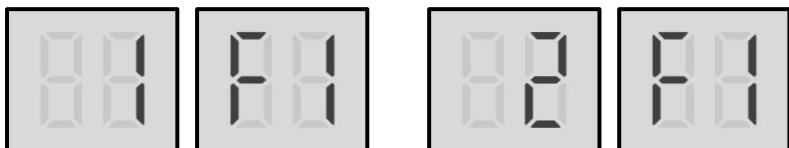

'x' is a placeholder for the compressor system (compressor and related electrical components), with 1 representing compressor system A and 2 representing compressor system B.

#### 2.10.2 Description

- 1F1 indicates compressor A DC bus voltage error; 2F1 indicates compressor B DC bus voltage error.
- All units stop running.
- Error code is only displayed on the unit with the error.

#### 2.10.3 Trigger / recover condition

- Trigger condition: DC bus voltage < 350V or DC bus voltage > 700V continuously for 10 seconds.
- Recover condition: DC bus voltage goes back to normal.
- Reset method: Restart automatically.

#### 2.10.4 Possible causes

- Loosened wiring of the compressor inverter module.
- Incorrect wiring of the reactor and DC bus wire.
- Abnormal power supply.
- Inverter module damaged.

2.10.5 Procedure

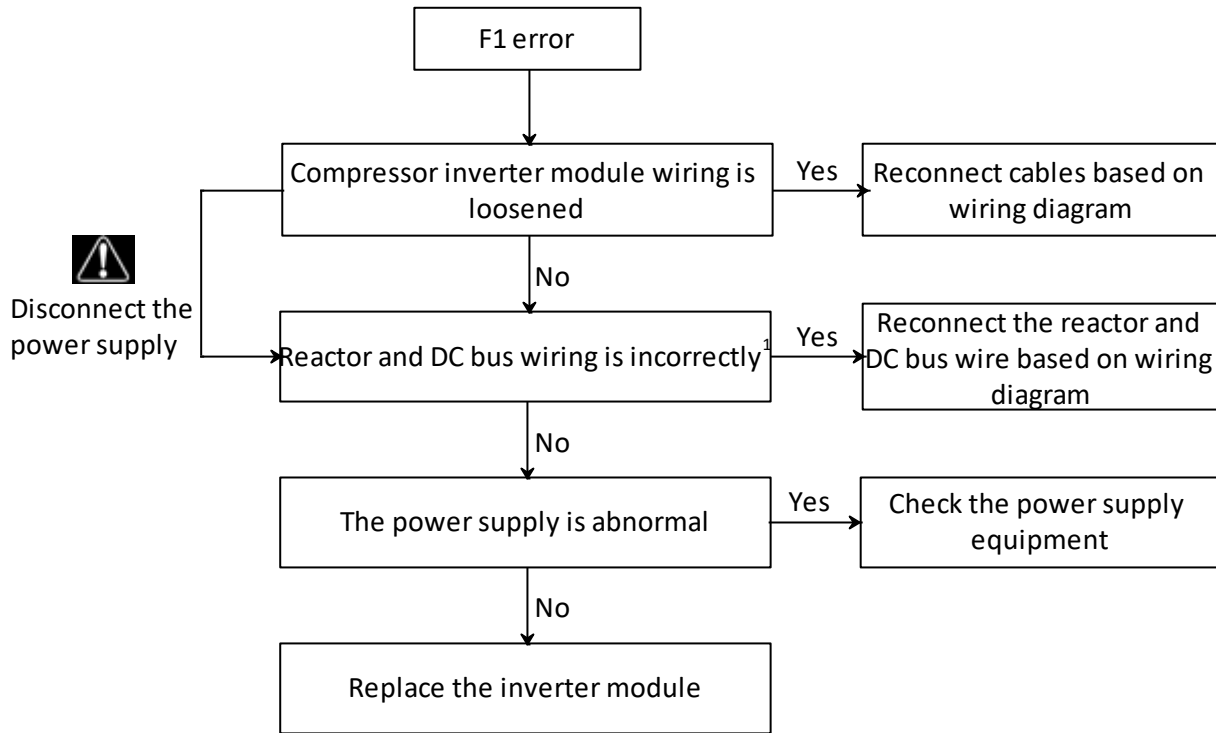

Note:

1. The DC bus wire should run from the N\_in terminal on the inverter module, through the current sensor (in the direction indicated by the arrow on the current sensor), and end at the N\_out terminal on the inverter module.

Figure 6-2.2: DC detection wire connection method



## Super X VRF 50/60Hz

### 2.11 F3, F5: Temperature sensor (T6B/T6A) error

#### 2.11.1 Digital display output

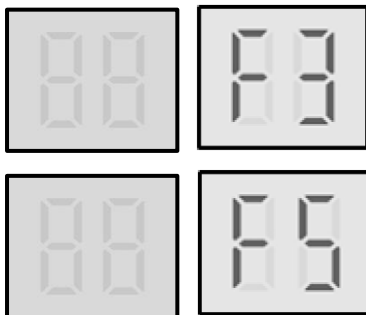

#### 2.11.2 Description

- F3 indicates plate heat exchanger cooling refrigerant outlet temperature sensor (T6B) error.
- F5 indicates plate heat exchanger cooling refrigerant inlet temperature sensor (T6A) error.
- All units stop running.
- Error code is only displayed on the unit with the error.

#### 2.11.3 Trigger / recover condition

- Trigger condition: Temperature sensor T6A(B) is open or short-circuit.
- Recover condition: Temperature sensor T6A(B) connection ports can detect load.
- Reset method: Resume automatically.

#### 2.11.4 Possible causes

- Temperature sensor not connected properly or has malfunctioned.
- Damaged main PCB.

## 2.11.5 Procedure

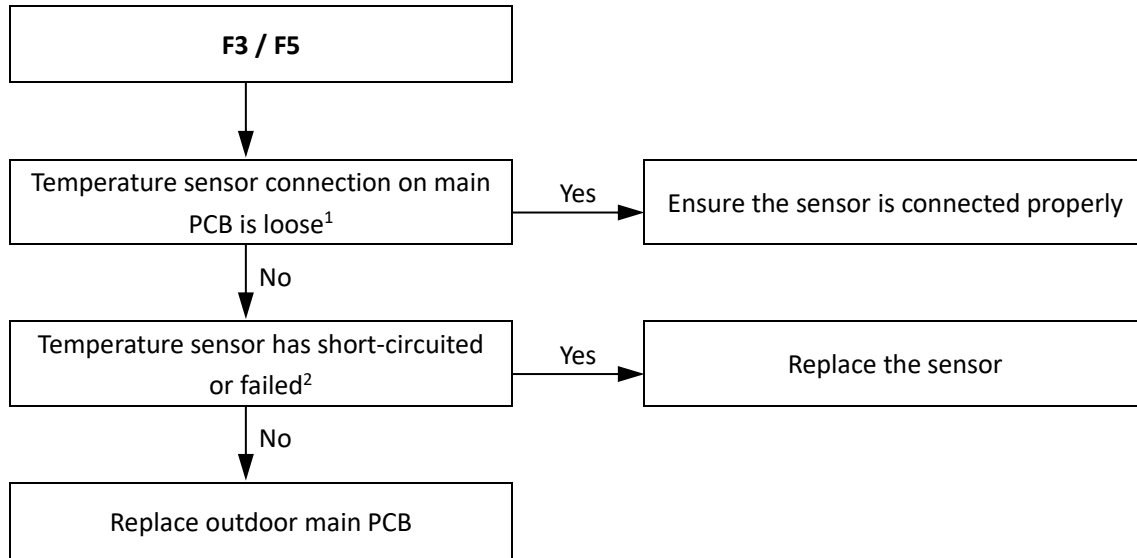

## Notes:

1. Plate heat exchanger cooling refrigerant inlet temperature sensor (T6A) and plate heat exchanger cooling refrigerant outlet temperature sensor (T6B) connection are port CN8 and CN8\_1 on the main PCB (labeled 10 and 12, respectively, in Figure 5-2.1 in Part 5, 2.1 "Ports").
2. Measure sensor resistance. If the resistance is too low, the sensor has short-circuited. If the resistance is not consistent with the sensor's resistance characteristics table, the sensor has failed. Refer to Table 6-3.1 in Part 6, 3.1 "Temperature Sensor Resistance Characteristics".

## Super X VRF 50/60Hz

### 2.12 F6: Electronic expansion valve connection error

#### 2.12.1 Digital display output

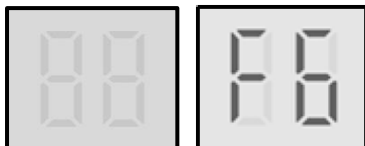

#### 2.12.2 Description

- Electronic expansion valve connection error.
- All units stop running.
- Error code is only displayed on the unit with the error.

#### 2.12.3 Trigger / recover condition

- Trigger condition: The main control board cannot receive the feedback signal of EXV.
- Recover condition: The main control board can receive the feedback signal of EXV.
- Reset method: When the main control board can receive the feedback signal of EXV, F6 flashes, a manual system restart is required before the system can resume operation.

#### 2.12.4 Possible causes

- Electronic expansion valve coil not connected properly or has malfunctioned.
- Damaged main PCB.

2.12.5 Procedure

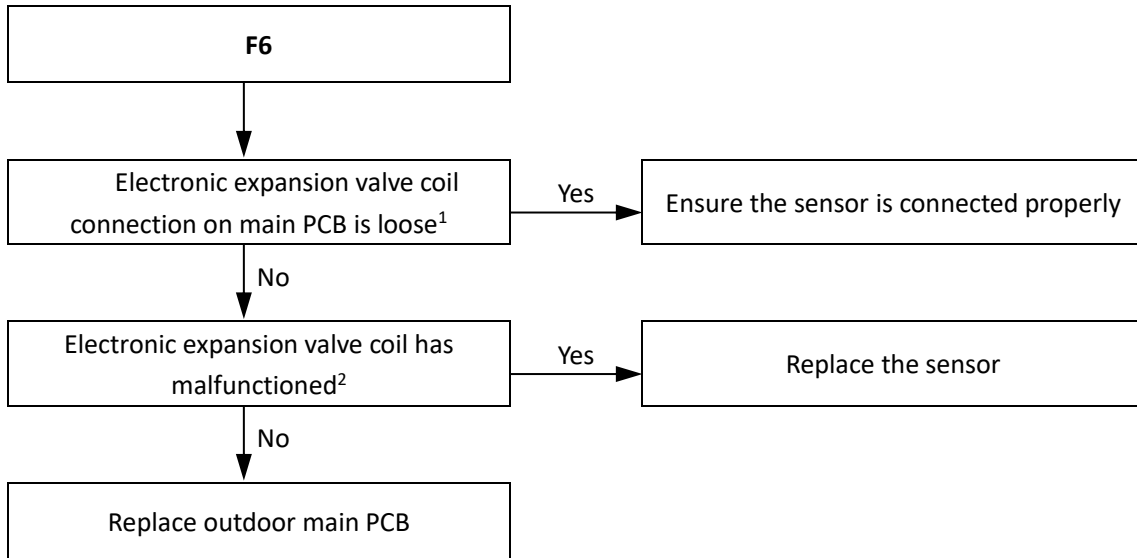

Notes:

1. Electronic expansion valve coil connections are port CN70, CN71 and CN72 on the main PCB (labeled 18, 19 and 20, respectively, in Figure 5-2.1 in Part 5, 2.1 "Ports").
2. The normal resistances between EXV coil wiring terminals RED and white / yellow / orange / blue are 40-50Ω. If any of the resistances differ from the value, the EXV coil has malfunctioned.

Figure 6-2.3: EXV coil wiring terminals

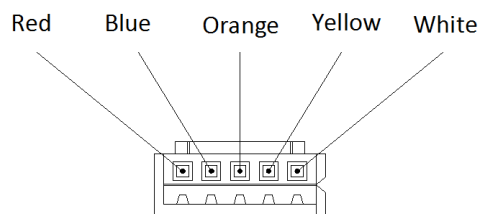

## 2.13 xH0: Communication error

### 2.13.1 Digital display output

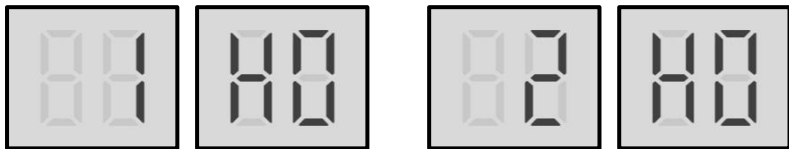

In the error code, 'x' is a placeholder for the compressor system (compressor and related electrical components), with 1 representing compressor system A and 2 representing compressor system B.

### 2.13.2 Description

- 1H0 indicates a communication error between the main control chip and the compressor A inverter driver chip.
- 2H0 indicates a communication error between the main control chip and the compressor B inverter driver chip.
- All units stop running.
- Error code is only displayed on the unit with the error.

### 2.13.3 Trigger / recover condition

- Trigger condition: Main control chip and inverter driver chip cannot communication for 2 minutes.
- Recover condition: Communication go back to normal.
- Reset method: Resume automatically.

### 2.13.4 Possible causes

- Incorrect compressor inverter module address setting.
- Loosened communication wiring from the main PCB to the inverter module.
- Bridge rectifier damaged.
- Main PCB damaged.
- Compressor inverter module damaged.

### 2.13.5 Procedure

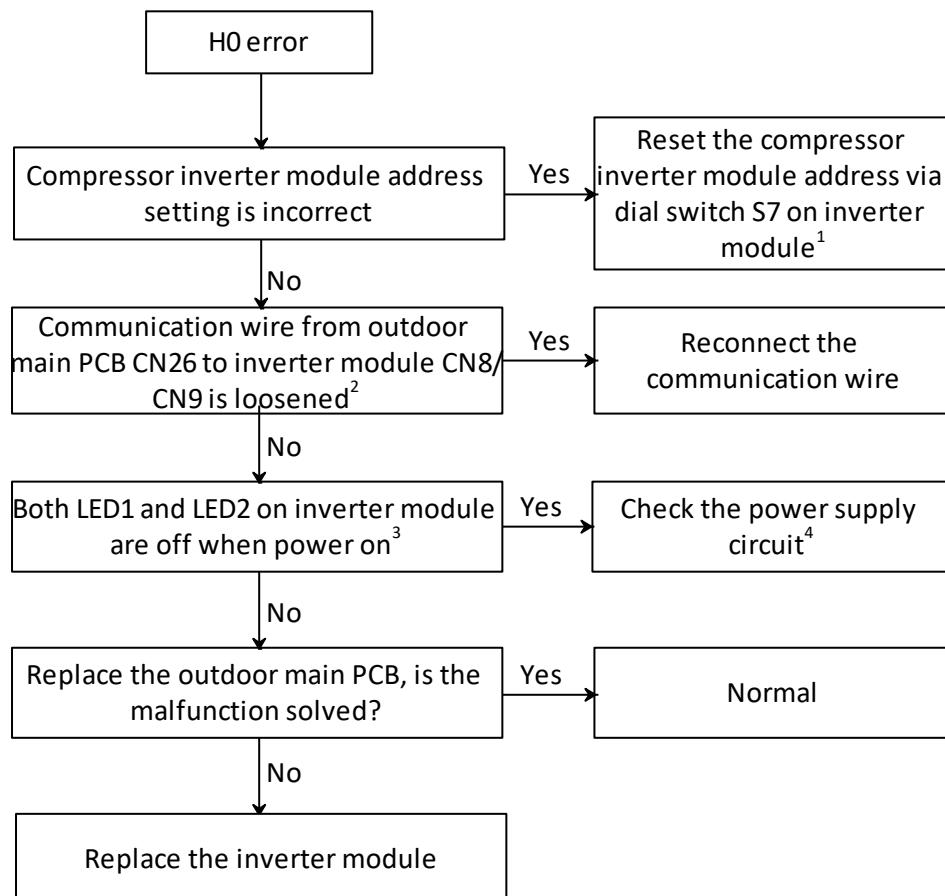

Notes:

- Compressor inverter module address is set through dial switch S7 on the inverter module. The compressor inverter module A/B location refers to the wiring diagram.

S7 on inverter module	Inverter module address
	0 for compressor inverter module A
	1 for compressor inverter module B

- Communication wire from outdoor main PCB CN26 to inverter module CN8/CN9.

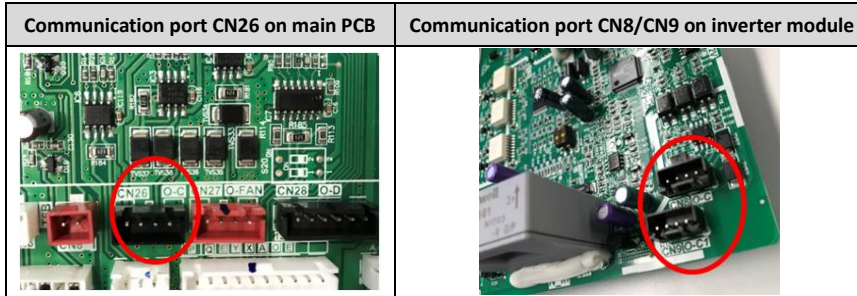

- LED1/2 on inverter module



- Check the power supply for the compressor inverter module, port CN41 on filter board, the normal voltage should be DC310V; check the high pressure switch connection port CN61 on filter board, the normal resistance should be zero; Check the single phase bridge and fuse on filter board; check the connection cable from ODU main PCB port CN82 to filter board port CN30 which is DC310V power control port.

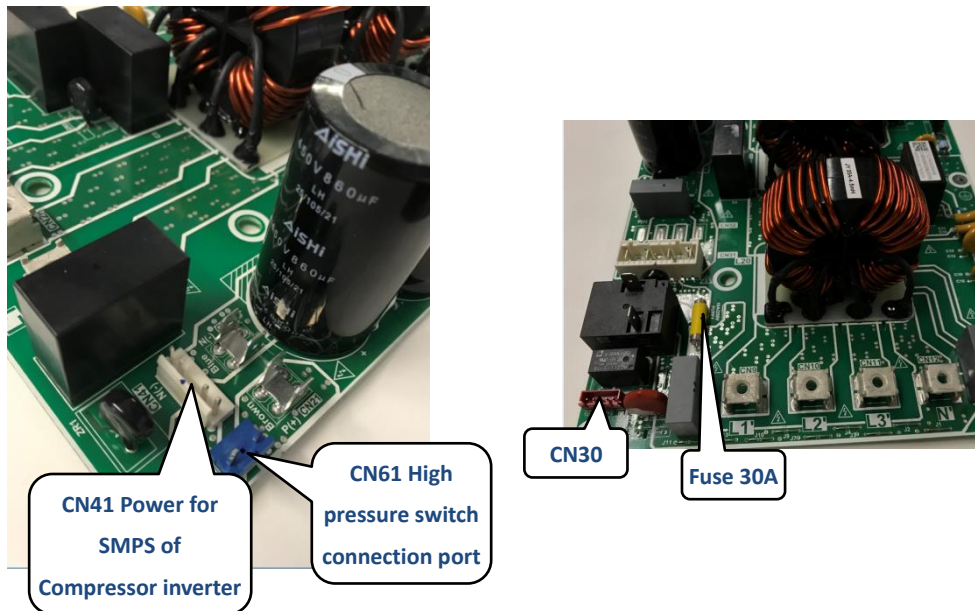



## Super X VRF 50/60Hz

### 2.14 H2, H3: Slave units decreased/increased

#### 2.14.1 Digital display output

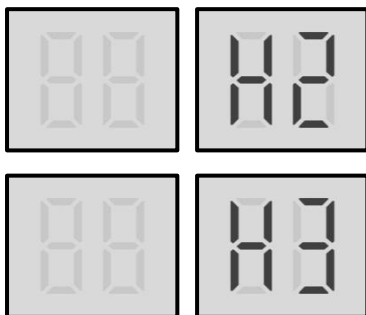

#### 2.14.2 Description

- H2 indicates that the number of slave units detected by master unit has decreased.
- H3 indicates that the number of slave units detected by master unit has increased.
- All units stop running.
- Error code is only displayed on the master unit.

#### 2.14.3 Trigger / recover condition

- Trigger condition: Number of slave units detected by master unit has decreased or increased.
- Recover condition: Number of slave units detected by master unit goes back to normal.
- Reset method: Resume automatically.

#### 2.14.4 Possible causes

- Some outdoor units are powered off.
- Power supply abnormal.
- Incorrect outdoor unit address setting.
- Communication wires between outdoor units not connected properly.
- Loosened wiring within electric control box.
- Damaged main PCB or electric control box communication terminals block.

2.14.5 Procedure

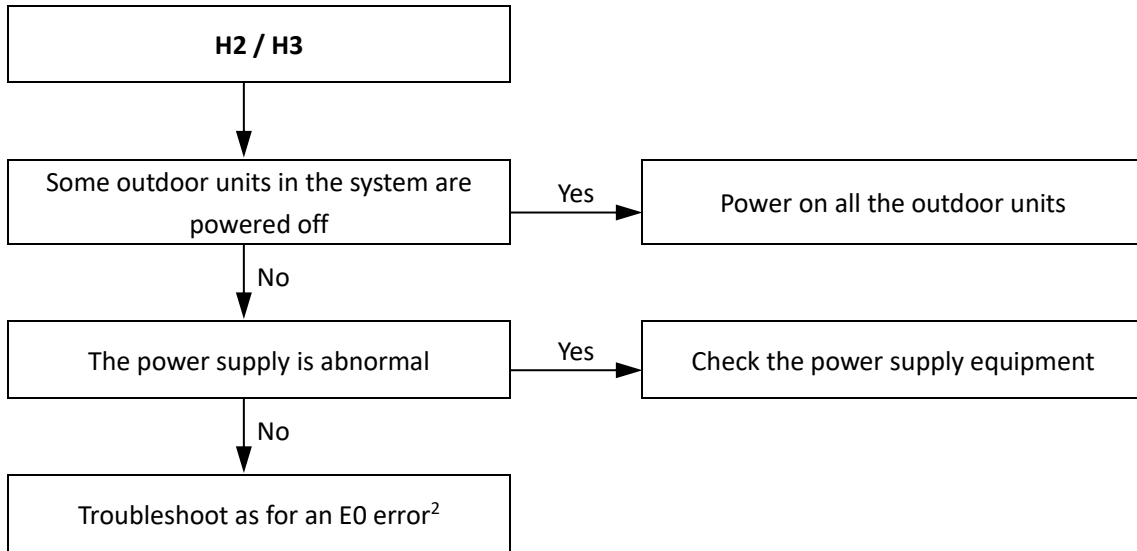

Notes:

1. See "E0 Troubleshooting".

# Super X VRF 50/60Hz

## 2.15 xH4: Inverter module protection

### 2.15.1 Digital display output

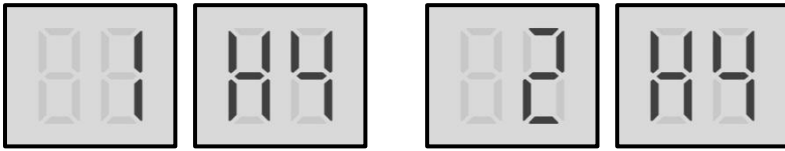

In the error code, 'x' is a placeholder for the compressor system (compressor and related electrical components), with 1 representing compressor system A and 2 representing compressor system B.

### 2.15.2 Description

- 1H4 indicates compressor A inverter module protection.
- 2H4 indicates compressor B inverter module protection.
- All units stop running.
- Error code is only displayed on the unit with the error.

### 2.15.3 Trigger / recover condition

- Trigger condition: Compressor appears three inverter module protections.
- Recover condition: Inverter module goes back to normal.
- Reset method: Manually restart.

### 2.15.4 Possible causes

- Inverter module protection.
- DC bus low or high voltage protection.
- MCE error.
- Zero speed protection.
- Phase sequence error.
- Excessive compressor frequency variation.
- Actual compressor frequency differs from target frequency.

### 2.15.5 Specific error codes for xH4 inverter module protection

If an xH4 error code is displayed, enter menu mode “n31” (refer to Part 5, 2.2.3 “menu mode”) to check the history error code to check the following specific error code: xL0, xL1, xL2, xL4, xL5, xL7, xL8, xL9.

Table 6-2.1: Specific error codes for error xH4

Specific error code <sup>1</sup>	Content
xL0	Inverter module protection
xL1	DC bus low voltage protection
xL2	DC bus high voltage protection
xL4	MCE error
xL5	Zero speed protection
xL7	Phase sequence error
xL8	Compressor frequency variation greater than 15Hz within one second protection
xL9	Actual compressor frequency differs from target frequency by more than 15Hz protection

Notes:

1. 'x' is a placeholder for the compressor system (compressor and related electrical components), with 1 representing compressor system A and 2 representing compressor system B.

The specific error codes xL0, xL1, xL2 and xL4 can also be obtained from the inverter module LED indicators. If an inverter module error has occurred, LED2 is continuously on and LED1 flashes.

Figure 6-2.4: LED indicators LED1 and LED2 on inverter module

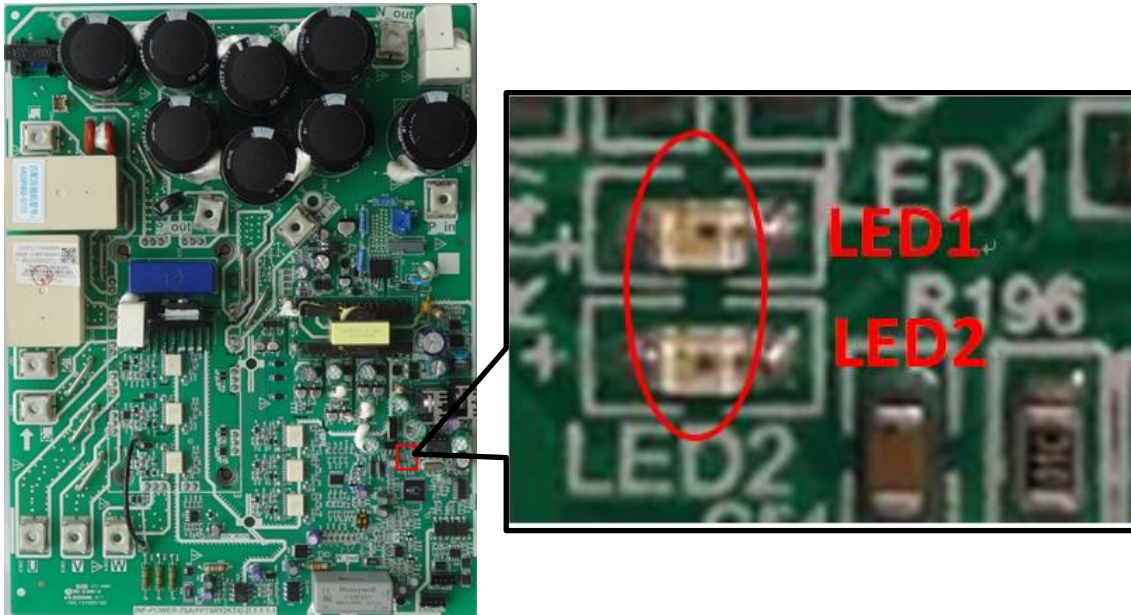
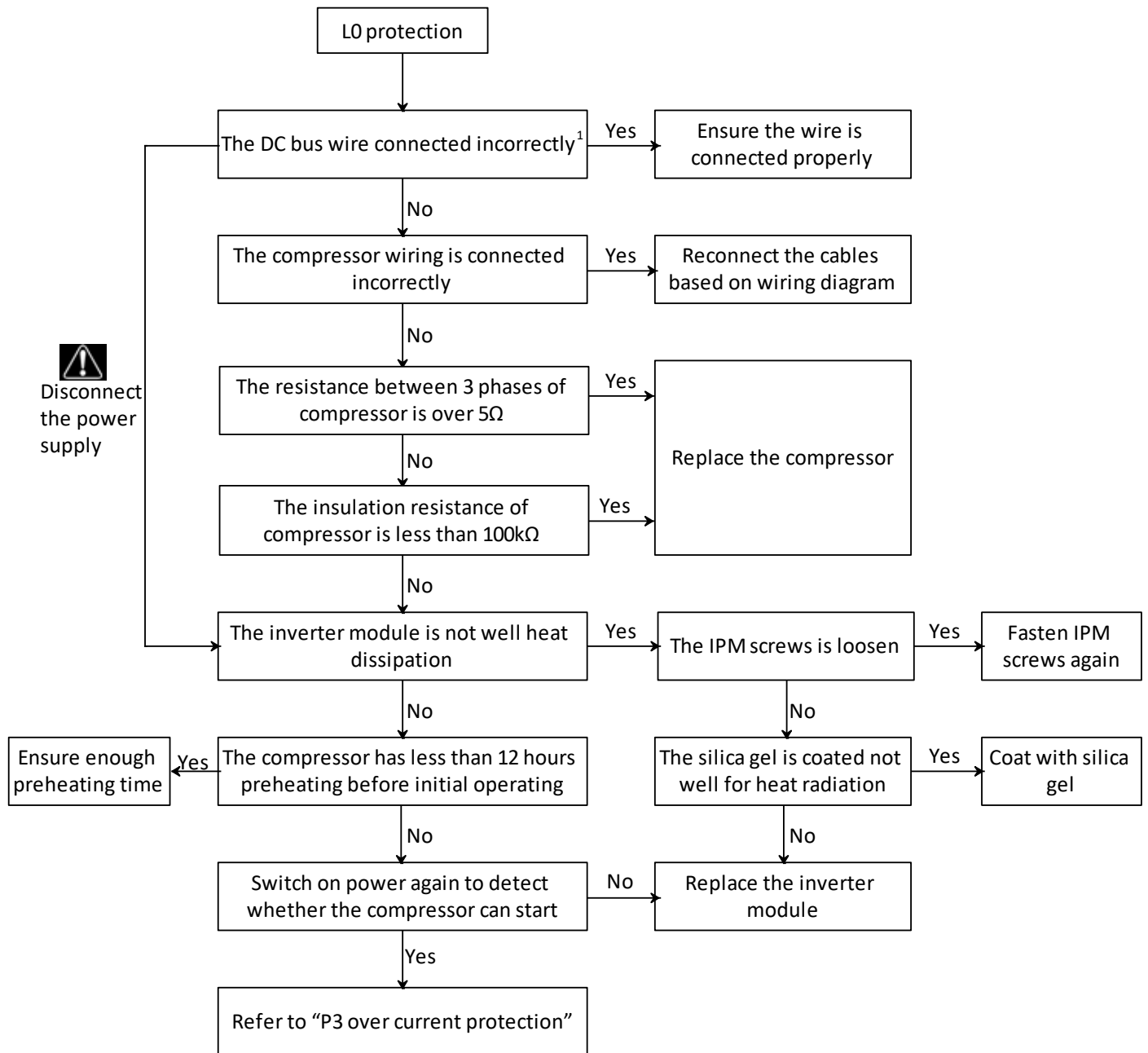

Table 5-3.2: Errors indicated on LED1

LED1 flashing pattern	Corresponding error
Flashes 8 times and stops for 1 second, then repeats	xL0 - Inverter module protection
Flashes 9 times and stops for 1 second, then repeats	xL1 - DC bus low voltage protection
Flashes 10 times and stops for 1 second, then repeats	xL2 - DC bus high voltage protection
Flashes 12 times and stops for 1 second, then repeats	xL4 - MCE error

## 2.15.6 L0: Inverter module protection



- Note:
- The DC bus wire should run from the N<sub>in</sub> terminal on the inverter module, through the current sensor (in the direction indicated by the arrow on the current sensor), and end at the N<sub>out</sub> terminal on the inverter module.

Figure 6-2.5: DC detection wire connection method



2.15.7 L1: DC bus low voltage protection

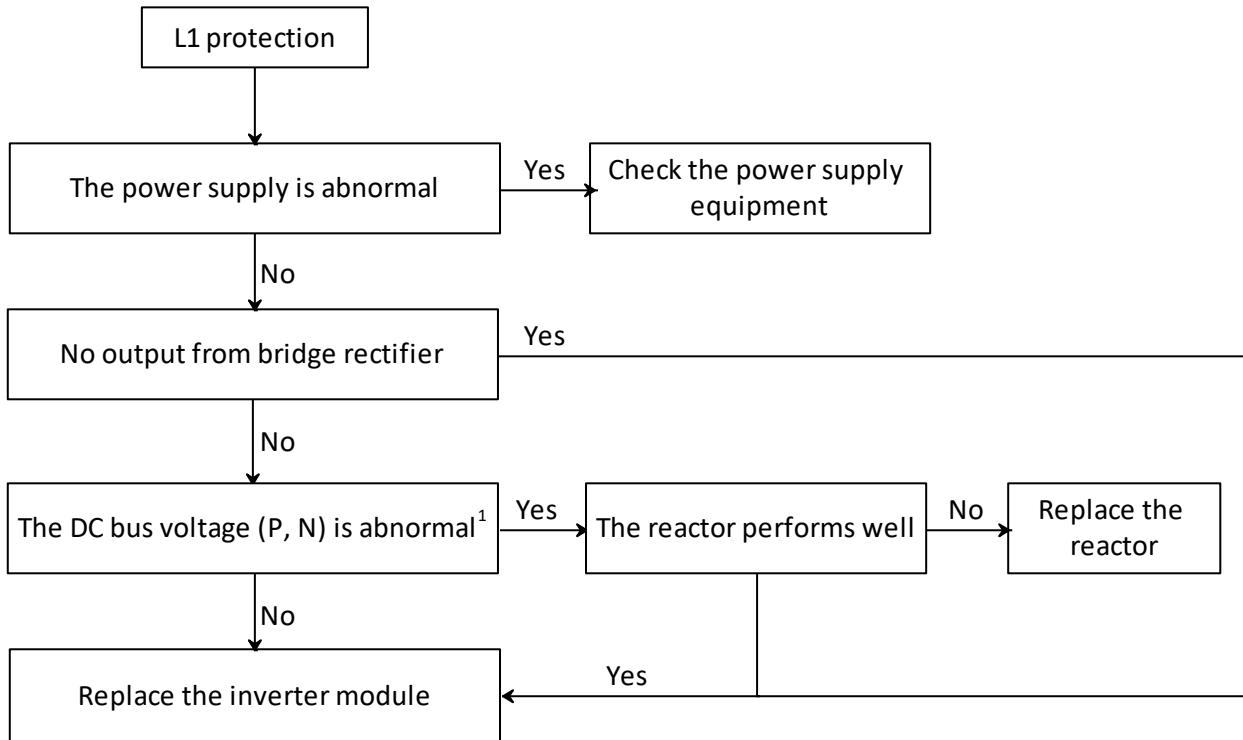

- Note:
1. The normal DC voltage between terminals P and N on inverter module should be 450-650V. When the voltage is lower than 350V, L1 protection will be appeared.

Figure 6-2.6: Inverter module terminals



## 2.15.8 L2: DC bus high voltage protection

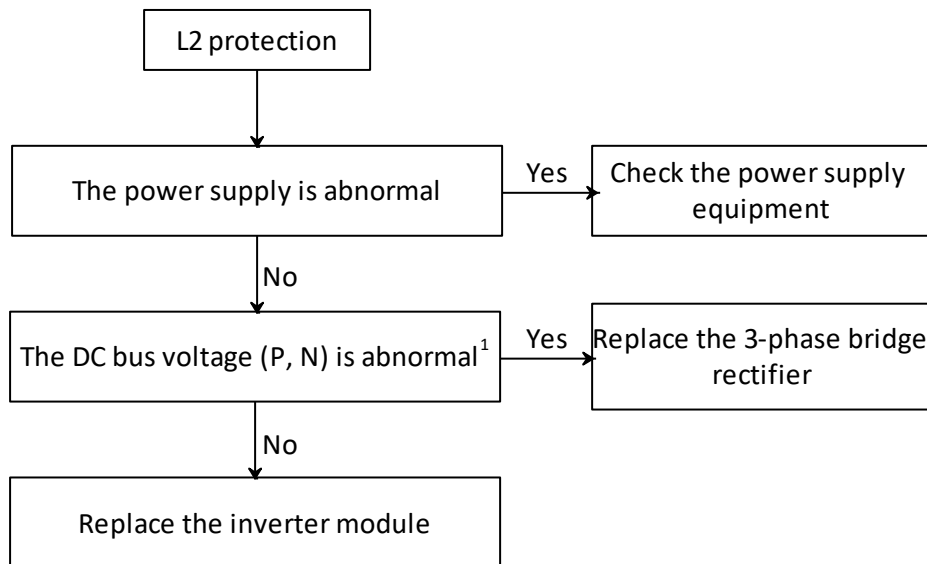

Note:

1. The normal DC voltage between terminals P and N on inverter module should be 450-650V. When the voltage is higher than 700V, L2 protection will be appeared.

Figure 6-2.7: Inverter module terminals



2.15.9 L4: MCE error



Disconnect the power supply

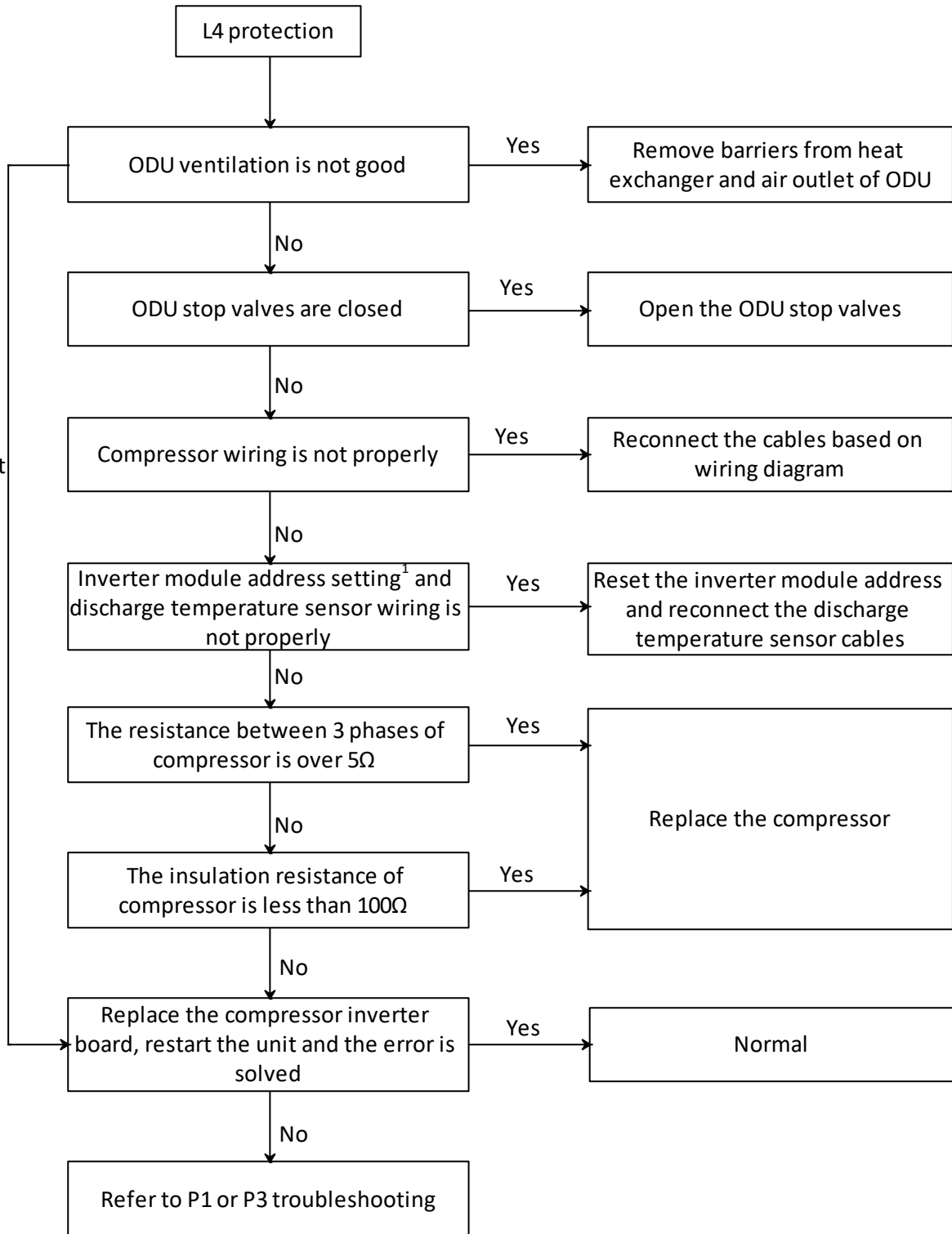

Notes:

- Compressor inverter module address is set through dial switch S7 on the inverter module. The compressor inverter module A/B location refers to the wiring diagram.

S7 on inverter module	Inverter module address
	0 for compressor inverter module A
	1 for compressor inverter module B



2.15.10 L7: Phase sequence error

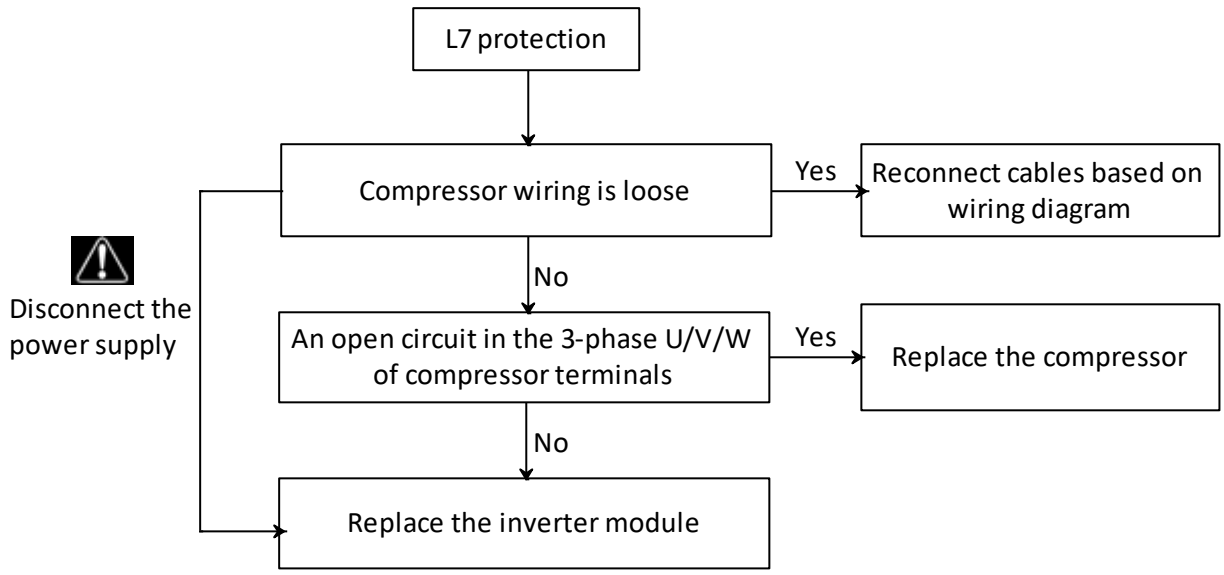

2.15.11 L8: Compressor frequency variation greater than 15Hz within one second protection

L9: Actual compressor frequency differs from target frequency by more than 15Hz protection

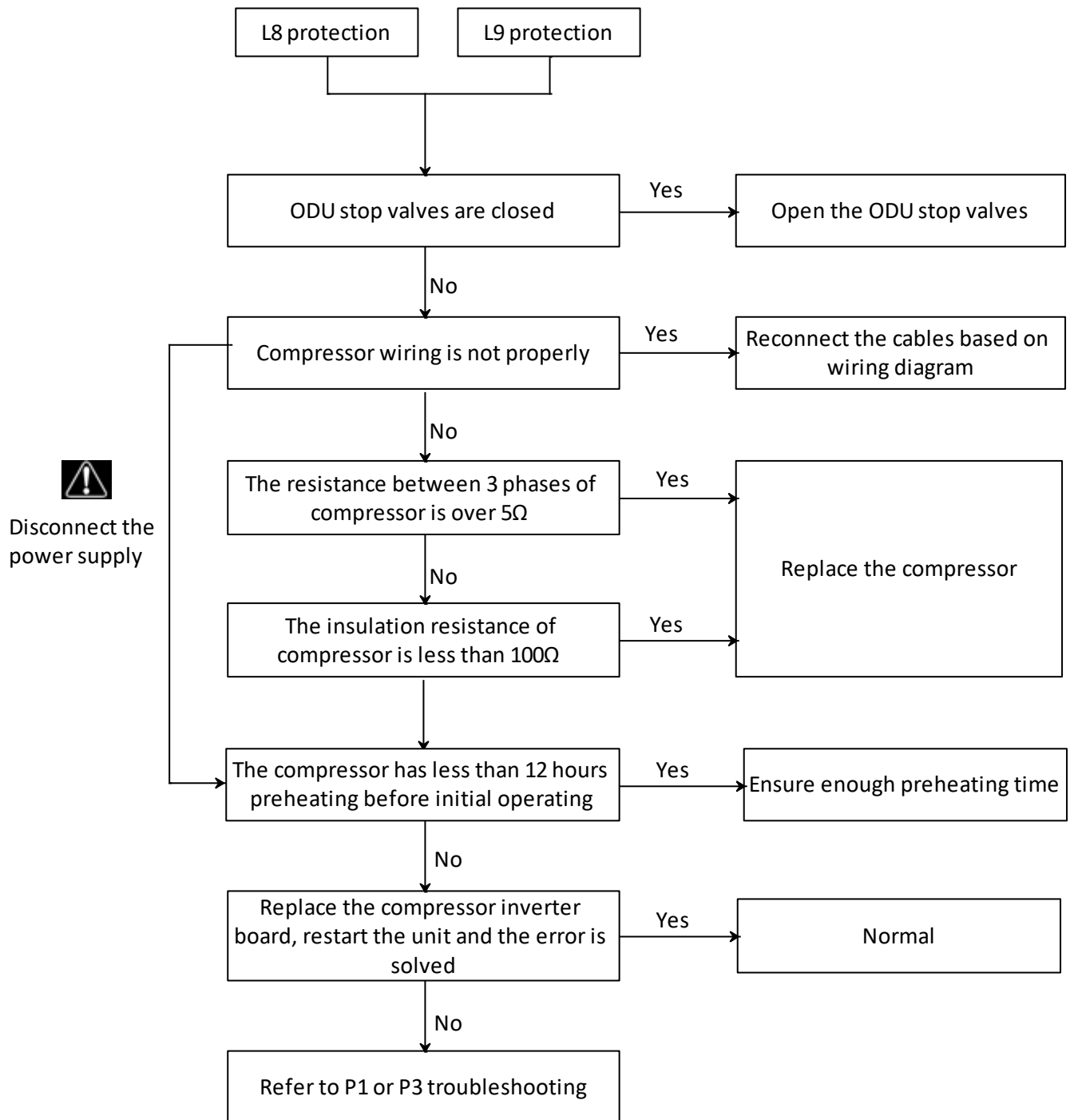

## 2.15.12 Compressor replacement procedure

### Step 1: Remove faulty compressor and remove oil

- Remove the faulty compressor from the outdoor unit.
- Before removing the oil, shake the compressor so as to not allow impurities to remain settled at the bottom.
- Drain the oil out of the compressor and retain it for inspection. Normally the oil can be drained out from the compressor discharge pipe.

Figure 6-2.8: Draining oil from a compressor



### Step 2: Inspect oil from faulty compressor

- The oil should be clear and transparent. Slightly yellow oil is not an indication of any problems. However, if the oil is dark, black or contains impurities, the system has problems and the oil needs to be changed. Refer to Figure 5-4.16 for further details regarding inspecting compressor oil. (If the compressor oil has been spoiled, the compressor will not be being lubricated effectively. The scroll plate, crankshaft and bearings will wear. Abrasion will lead to a larger load and higher current. More electric energy will get dissipated as heat and the temperature of the motor will become increasingly high. Finally, compressor damage or burnout will result.)

### Step 3: Check oil in other compressors in the system

- If the oil drained from the faulty compressor is clean, go to Step 6.
- If the oil drained from the faulty compressor is only lightly spoiled, go to Step 4.
- If the oil drained from the faulty compressor is heavily spoiled, check the oil in the other compressors in the system. Drain the oil from any compressors where the oil has been spoiled. Go to Step 4.

### Step 4: Replace oil separator(s) and accumulator(s)

- If the oil from a compressor is spoiled (lightly or heavily), drain the oil from the oil separator and accumulator in that unit and then replace them.

### Step 5: Check filters(s)

- If the oil from a compressor is spoiled (lightly or heavily), check the filter between the gas stop valve and the 4-way valve in that unit. If it is blocked, clean with nitrogen or replace.

### Step 6: Replace the faulty compressor and re-fit the other compressors

- Replace the faulty compressor.
- If the oil had been spoiled and was drained from the non-faulty compressors in Step 3, use clean oil to clean them before re-fitting them into the units. To clean, add oil into the compressor through the discharge pipe using a funnel, shake the compressor, and then drain the oil. Repeat several times and then re-fit the compressors into the units. (The discharge pipe is connected to the oil pool of the compressor by the inner oil balance pipe.)

Figure 6-2.9: Compressor piping

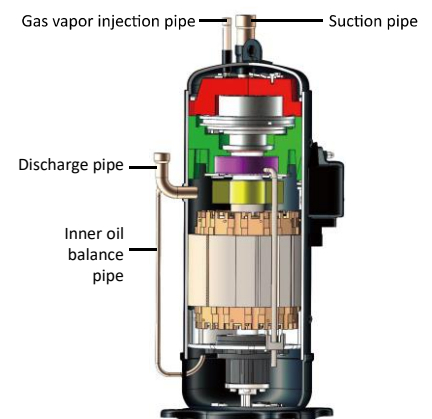

### Step 7: Add compressor oil

- Add 1.2L of oil to the new compressor through the discharge pipe, using a funnel.
- Add 1.2L of oil to each of the compressors from which oil was drained in Step 3.
- Only use FV68H oil. Different compressors require different types of oil. Using the wrong type of oil leads to various problems.
- Add additional oil to the accumulators such that the total amount of oil is 5L in 8-12HP units, 6L in 14-16HP units 7L in 18-22HP units, 9L in 24-28HP units and 10L in 30-32HP units.

**Step 8: Vacuum drying and refrigerant charging**

- Once all the compressors and other components have been fully connected, vacuum dry the system and recharge refrigerant. Refer to the V6 Engineering Data Book, Part 3.

Figure 6-2.10: Inspecting compressor oil

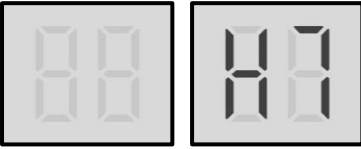

Figure 6-2.11: Effects of spoiled compressor oil



## 2.16 H7: Unmatched total number of indoor units

### 2.16.1 Digital display output



### 2.16.2 Description

- Number of indoor units detected by master unit not same as number set on main PCB.
- All units stop running.
- Error code is only displayed on the master unit.

### 2.16.3 Trigger / recover condition

- Trigger condition: Only one indoor unit cannot be detected by master unit for 8 hours or more than one indoor unit cannot be detected by master unit for 3 minutes.
- Recover condition: Number of indoor units detected by master unit is same as number set on main PCB.
- Reset method: Resume automatically.

### 2.16.4 Possible causes

- Number of indoor units set on main PCB not same as actual number of indoor units.
- Some indoor units are powered off.
- Communication wires between indoor and outdoor units not connected properly.
- Indoor unit PCB damaged.
- Indoor unit without address or indoor unit address duplicated.
- Main PCB damaged.

## 2.16.5 Procedure

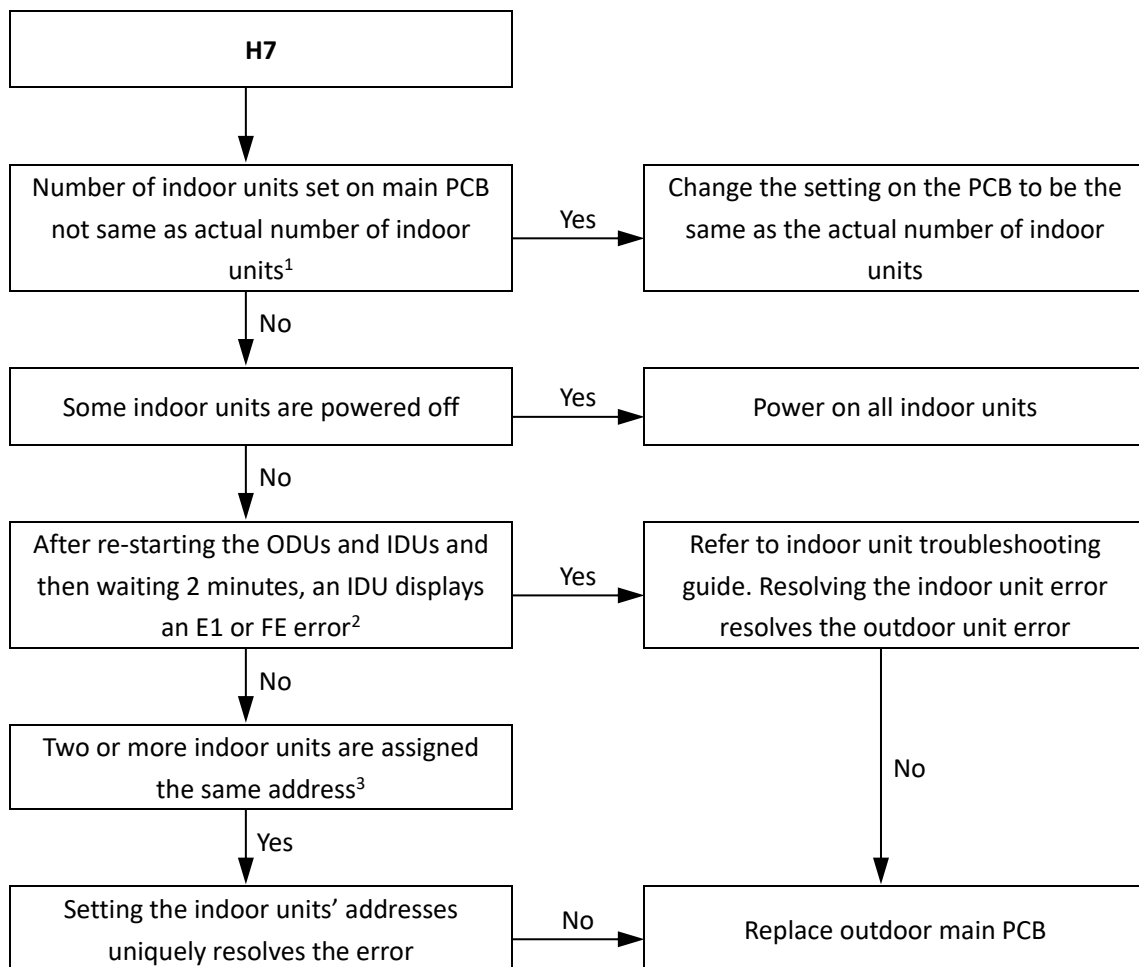

Notes:

1. The number of indoor units can be set on switches EN3 and S12 on the main PCB.
2. Indoor unit error code E1 indicates a communication error between indoor and master unit. Indoor unit error code FE indicates that an indoor unit has not been assigned an address.
3. Indoor unit addresses can be checked and manually assigned using indoor unit remote/wired controllers. Alternatively, indoor unit addresses can be automatically assigned by the master outdoor unit.

## 2.17 H8: High pressure sensor error

### 2.17.1 Digital display output

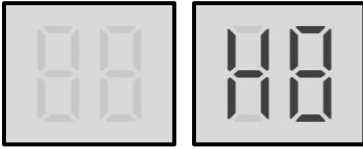

### 2.17.2 Description

- High pressure sensor error.
- All units stop running.
- Error code is only displayed on the unit with the error.

### 2.17.3 Trigger / recover condition

- Trigger condition: Discharge pressure  $\leq$  0.3MPa.
- Recover condition: Discharge pressure  $>$  0.3MPa.
- Reset method: Resume automatically.

### 2.17.4 Possible causes

- Outdoor unit stop valves are closed.
- Pressure sensor not connected properly or has malfunctioned.
- Insufficient refrigerant.
- Low pressure side blockage.
- Poor evaporator heat exchange.
- Main PCB damaged.



## 2.17.5 Procedure

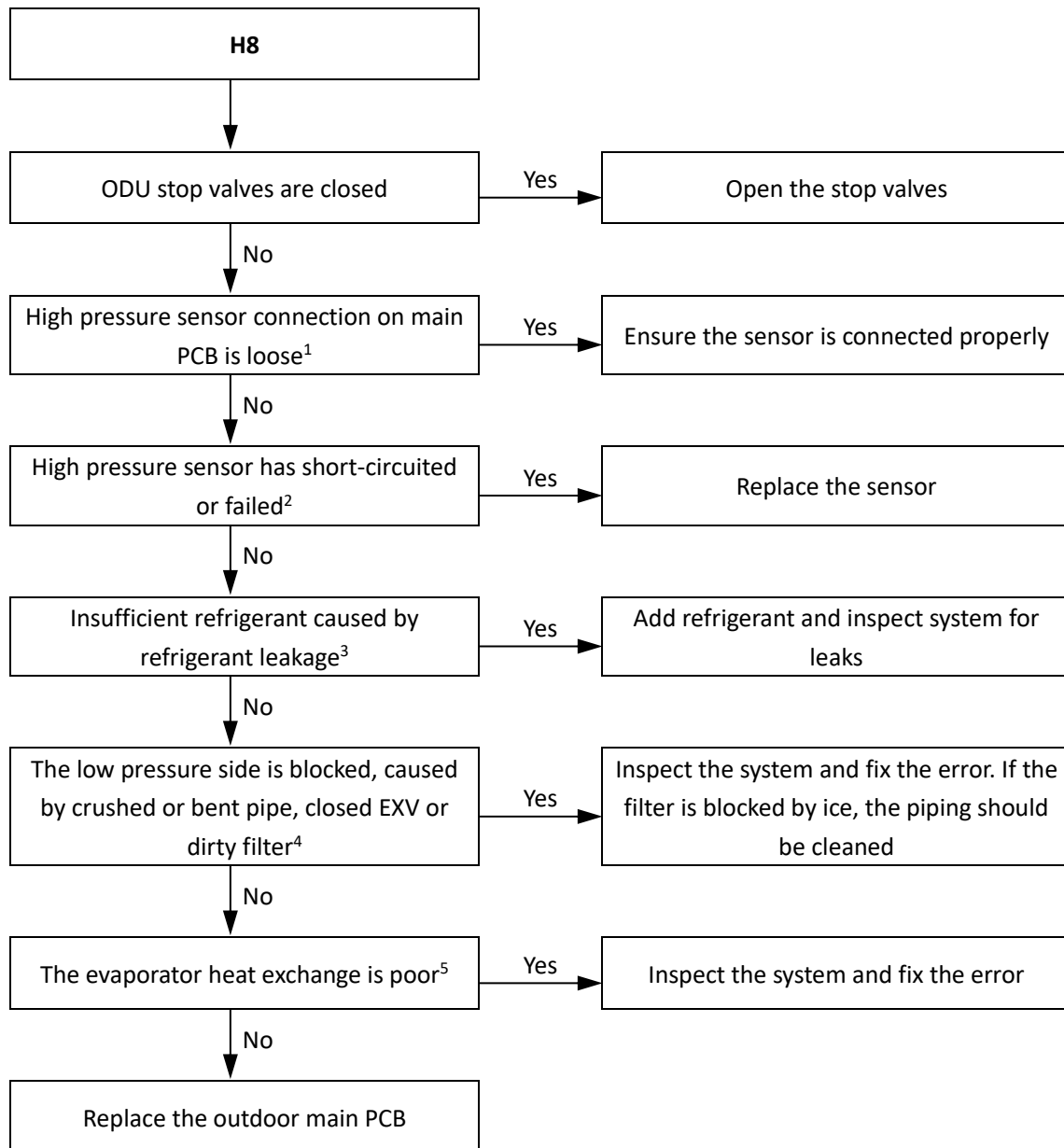

### Notes:

1. High pressure sensor connection is port CN17 on the main PCB (labeled 7 in Figure 5-2.1 in Part 5, 2.1 "Ports").
2. Measure the resistance among the three terminals of the pressure sensor. If the resistance is of the order of mega Ohms or infinite, the pressure sensor has failed.
3. An insufficiency of refrigerant causes compressor discharge temperature to be higher than normal, discharge and suction pressures to be lower than normal and compressor current to be lower than normal, and may cause frosting to occur on the suction pipe. These issues disappear once sufficient refrigerant has been charged into the system. For normal system parameters refer to Table 6-3.4 and 6-3.5 in Part 6, 3.2 "Normal Operating Parameters of Refrigerant System".
4. A low pressure side blockage causes compressor discharge temperature to be higher than normal, suction pressure to be lower than normal and compressor current to be lower than normal, and may cause frosting to occur on the suction pipe. For normal system parameters refer to Table 6-3.4 and 6-3.5 in Part 6, 3.2 "Normal Operating Parameters of Refrigerant System".
5. In cooling mode check indoor heat exchangers, fans and air outlets for dirt/blockages. In heating mode check outdoor heat exchangers, fans and air outlets for dirt/blockages.

## 2.18 yHd: Slave unit malfunction

### 2.18.1 Digital display output

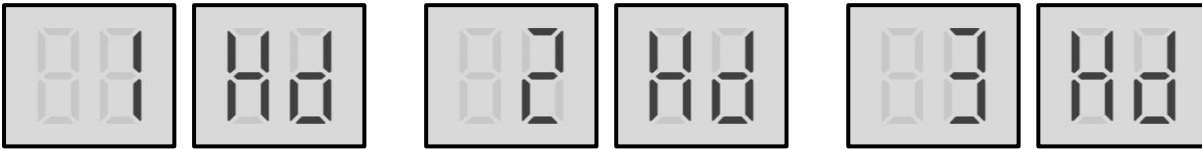

In the error code, 'y' is a placeholder for the address (1, 2 or 3) of the slave unit with the error.

### 2.18.2 Description

- 1Hd indicates an error on the slave unit with address 1.
- 2Hd indicates an error on the slave unit with address 2.
- 3Hd indicates an error on the slave unit with address 3.
- All units stop running.
- Error code is only displayed on the master unit.

### 2.18.3 Trigger / recover condition

- Trigger condition: Slave unit is malfunction.
- Recover condition: Slave unit goes back to normal.
- Reset method: Resume automatically.

### 2.18.4 Possible causes

- Slave unit malfunction.

## 2.18.5 Procedure

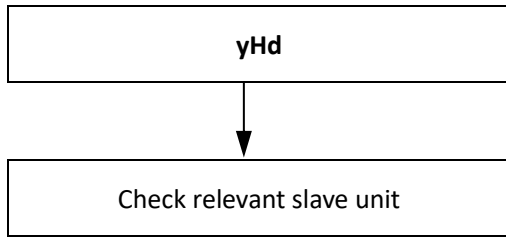

## 2.19 P1: Discharge pipe high pressure protection

### 2.19.1 Digital display output

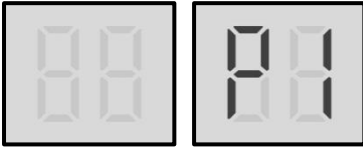

### 2.19.2 Description

- Discharge pipe high pressure protection. If the system has a 3-phase protector and the 3-phase protector is connected with the high pressure switch, the system will display P1 protection when initially powered on, and P1 protection will disappear once the system reaches a steady state.
- All units stop running.
- Error code is only displayed on the unit with the error.

### 2.19.3 Trigger / recover condition

- Trigger condition: Discharge pressure  $\geq 4.4$ MPa.
- Recover condition: Discharge pressure  $\leq 3.2$ MPa.
- Reset method: Resume automatically.

### 2.19.4 Possible causes

- Outdoor unit stop valves are closed.
- Pressure sensor/switch not connected properly or has malfunctioned.
- Excess refrigerant.
- System contains air or nitrogen.
- High pressure side blockage.
- Poor condenser heat exchange.
- Main PCB damaged.

### 2.19.5 Procedure

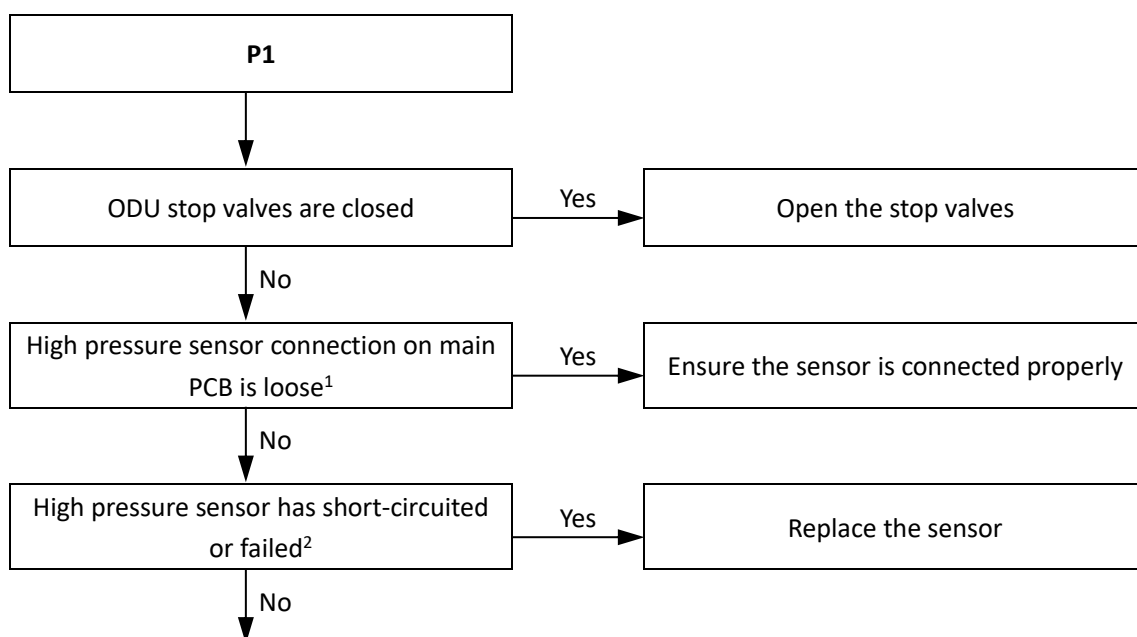

Flowchart continued on next page ...

... flowchart continued from previous page

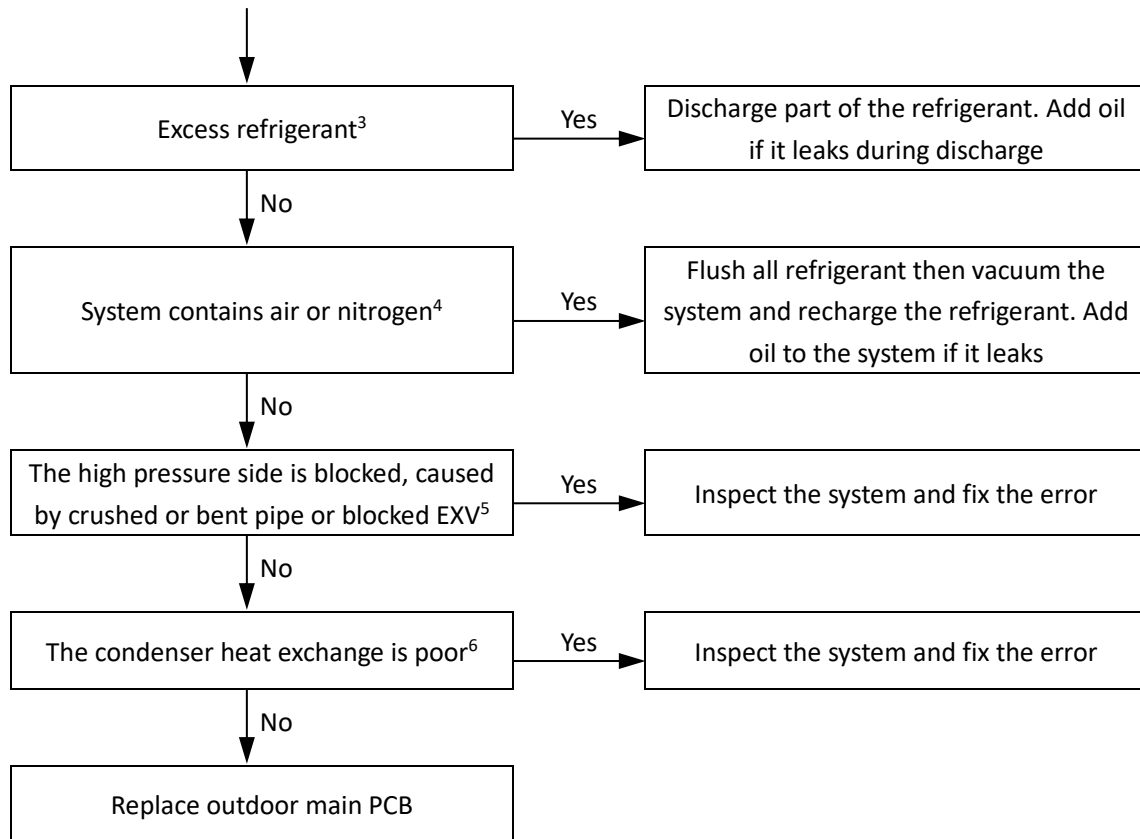

Notes:

1. The high pressure sensor connection is port CN17 on the main PCB (labeled 7 in Figure 5-2.1 in Part 5, 2.1 "Ports").
2. Measure the resistance among the three terminals of the pressure sensor. If the resistance is of the order of mega Ohms or infinite, the pressure sensor has failed.
3. Excess refrigerant causes discharge temperature to be lower than normal, discharge pressure to be higher than normal and suction pressure to be higher than normal. For normal system parameters refer to Table 6-3.4 and 6-3.5 in Part 6, 3.2 "Normal Operating Parameters of Refrigerant System".
4. Air or nitrogen in the system causes discharge temperature to be higher than normal, discharge pressure to be higher than normal, compressor current to be higher than normal, abnormal compressor noise and an unsteady pressure meter reading. For normal system parameters refer to Table 6-3.4 and 6-3.5 in Part 6, 3.2 "Normal Operating Parameters of Refrigerant System".
5. High pressure side blockage causes discharge temperature to be higher than normal, discharge pressure to be higher than normal and suction pressure to be lower than normal. For normal system parameters refer to Table 6-3.4 and 6-3.5 in Part 6, 3.2 "Normal Operating Parameters of Refrigerant System".
6. In cooling mode check outdoor heat exchangers, fans and air outlets for dirt/blockages. In heating mode check indoor heat exchangers, fans and air outlets for dirt/blockages.

## 2.20 P2, H5: Suction pipe low pressure protection

### 2.20.1 Digital display output

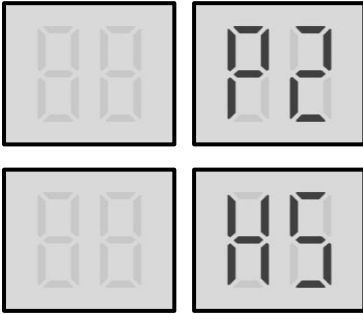

### 2.20.2 Description

- Suction pipe low pressure protection. If the system has a 3-phase protector and the 3-phase protector is connected to the low pressure switch, the system will display P2 protection when initially powered on, and P2 protection will disappear once the system reaches a steady state.
- All units stop running.
- Error code is only displayed on the unit with the error.

### 2.20.3 Trigger / recover condition

- Trigger condition:
  - For P2 protection: Suction pressure  $\leq 0.05\text{MPa}$ .
  - For H5 protection: P2 protection appears three times in 60 minutes.
- Recover condition: Suction pressure  $\geq 0.15\text{MPa}$ .
- Reset method:
  - For P2 protection: Resume automatically.
  - For H5 protection: Manually restart.

### 2.20.4 Possible causes

- Outdoor unit stop valves are closed.
- Insufficient refrigerant.
- Low pressure side blockage.
- Poor evaporator heat exchange.
- Main PCB damaged.

## 2.20.5 Procedure

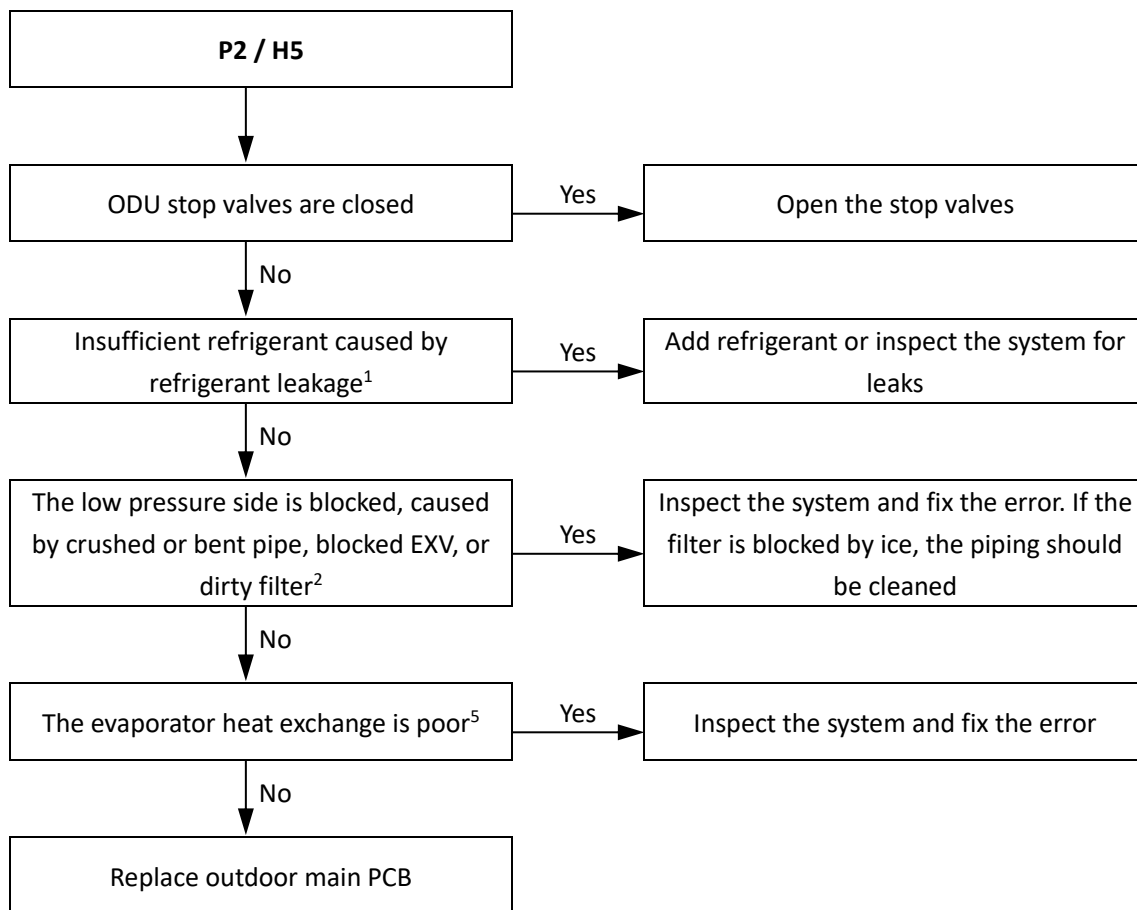

Notes:

1. An insufficiency of refrigerant causes compressor discharge temperature to be higher than normal, discharge and suction pressures to be lower than normal and compressor current to be lower than normal, and may cause frosting to occur on the suction pipe. These issues disappear once sufficient refrigerant has been charged into the system. For normal system parameters refer to Table 6-3.4 and 6-3.5 in Part 6, 3.2 "Normal Operating Parameters of Refrigerant System".
2. A low pressure side blockage causes compressor discharge temperature to be higher than normal, suction pressure to be lower than normal and compressor current to be lower than normal, and may cause frosting to occur on the suction pipe. For normal system parameters refer to Table 6-3.4 and 6-3.5 in Part 6, 3.2 "Normal Operating Parameters of Refrigerant System".
3. In cooling mode check indoor heat exchangers, fans and air outlets for dirt/blockages. In heating mode check outdoor heat exchangers, fans and air outlets for dirt/blockages.

## 2.21 xP3: Compressor current protection

### 2.21.1 Digital display output

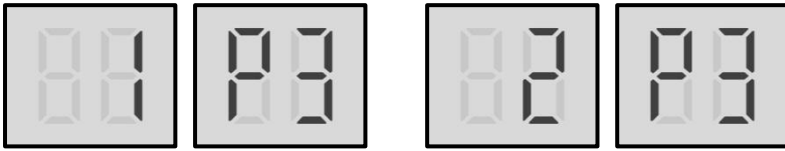

'x' is a placeholder for the compressor system (compressor and related electrical components), with 1 representing compressor system A and 2 representing compressor system B.

### 2.21.2 Description

- 1P3 indicates current protection on compressor A; 2P3 indicates current protection on compressor B.
- All units stop running.
- Error code is only displayed on the unit with the error.

### 2.21.3 Trigger / recover condition

- Trigger condition: Current of compressor AA55PHDG –D1YG  $\geq 24.6A$  or DC80PHDG –D1YG  $\geq 33A$ .
- Recover condition: Current of compressor AA55PHDG –D1YG  $< 24.6A$  or DC80PHDG –D1YG  $< 33A$ .
- Reset method: Resume automatically.

### 2.21.4 Possible causes

- Outdoor unit stop valves are closed.
- Indoor load too large.
- Power supply abnormal.
- Sudden interruption of power to IDUs.
- Excess refrigerant.
- System contains air or nitrogen.
- Poor condenser heat exchange.
- High pressure side blockage.
- Inverter module damaged.
- Compressor damaged.
- Main PCB damaged.

### 2.21.5 Procedure

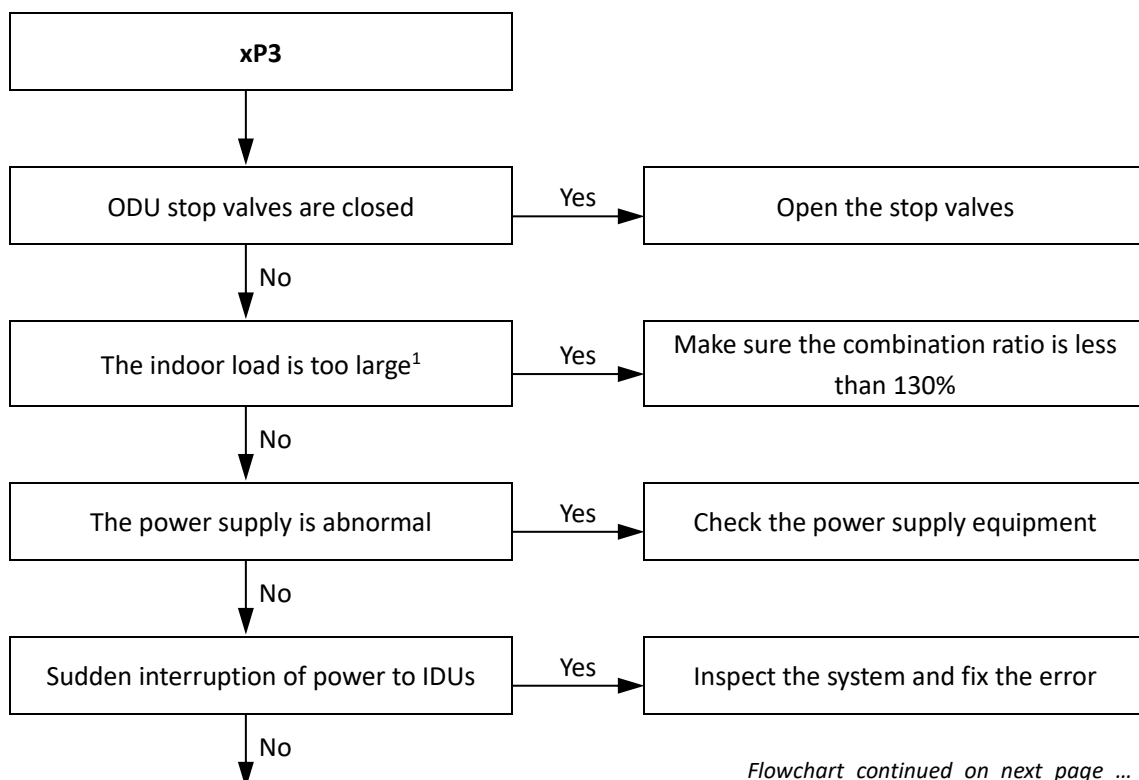



... flowchart continued from previous page

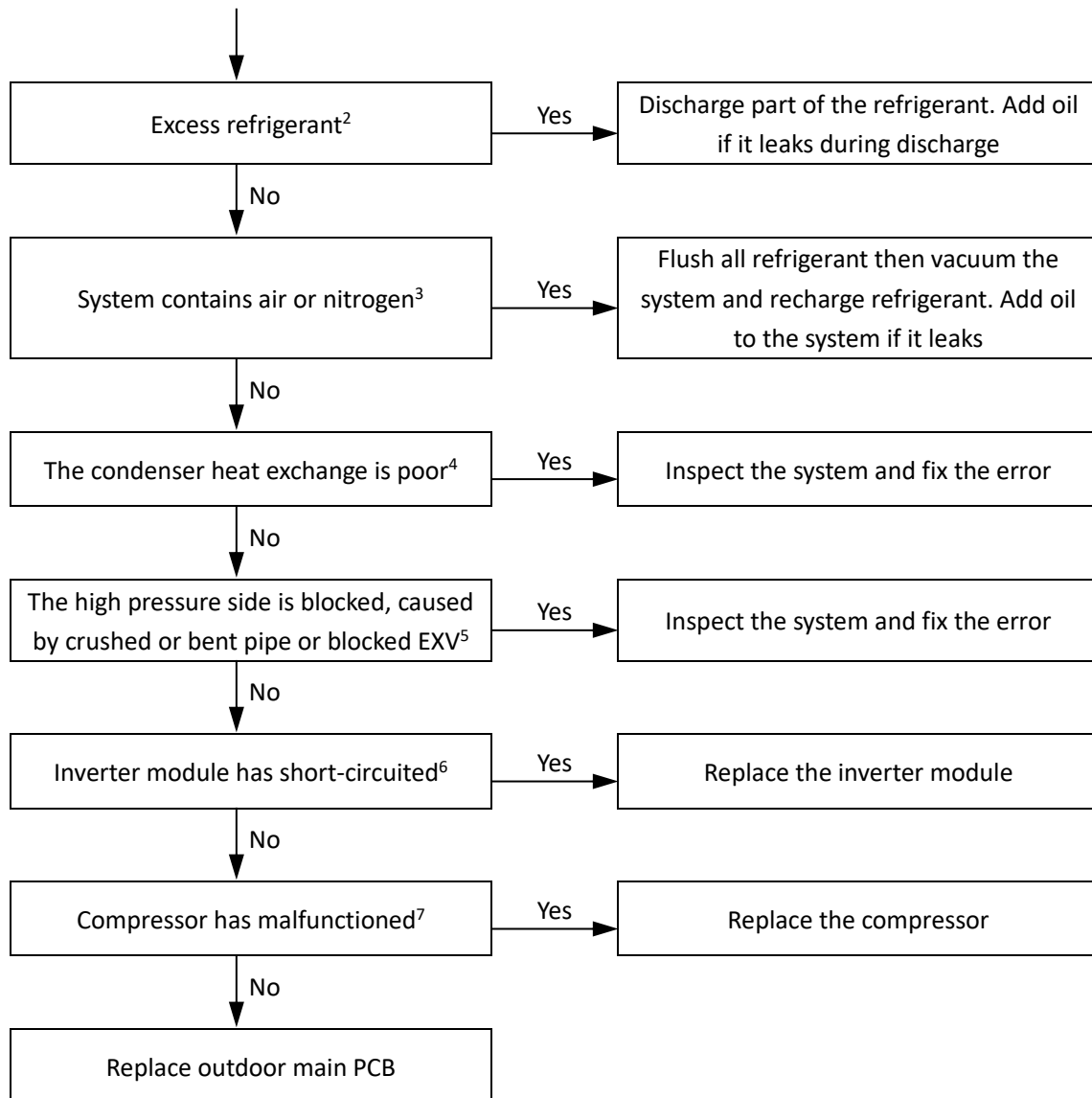

Notes:

1. An indoor load that is too large causes suction and discharge temperatures to be higher than normal. For normal system parameters refer to Table 6-3.4 and 6-3.5 in Part 6, 3.2 "Normal Operating Parameters of Refrigerant System".
2. Excess refrigerant causes discharge temperature to be lower than normal, discharge pressure to be higher than normal and suction pressure to be higher than normal. For normal system parameters refer to Table 6-3.4 and 6-3.5 in Part 6, 3.2 "Normal Operating Parameters of Refrigerant System".
3. Air or nitrogen in the system causes discharge temperature to be higher than normal, discharge pressure to be higher than normal, compressor current to be higher than normal, abnormal compressor noise and an unsteady pressure meter reading. For normal system parameters refer to Table 6-3.4 and 6-3.5 in Part 6, 3.2 "Normal Operating Parameters of Refrigerant System".
4. In cooling mode check outdoor heat exchangers, fans and air outlets for dirt/blockages. In heating mode check indoor heat exchangers, fans and air outlets for dirt/blockages.
5. High pressure side blockage causes discharge temperature to be higher than normal, discharge pressure to be higher than normal and suction pressure to be lower than normal. For normal system parameters refer to Table 6-3.4 and 6-3.5 in Part 6, 3.2 "Normal Operating Parameters of Refrigerant System".
6. Set a multi-meter to buzzer mode and test any two terminals of P N U V W of the inverter module. If the buzzer sounds, the inverter module has short-circuited.
7. The normal resistances of the inverter compressor are 0.7-1.5Ω among U V W and infinite between each of U V W and ground. If any of the resistances differ from these specifications, the compressor has malfunctioned.

## 2.22 P4, H6: Discharge temperature protection

### 2.22.1 Digital display output

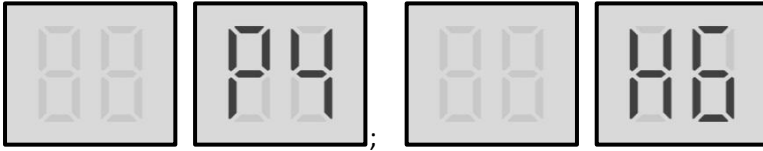

### 2.22.2 Description

- Discharge temperature protection.
- All units stop running.
- Error code is only displayed on the unit with the error.

### 2.22.3 Trigger / recover condition

- Trigger condition:
  - For P4 protection: Discharge temperature (T7C1/2)  $\geq 120^{\circ}\text{C}$ .
  - For H6 protection: P4 protection appears three times in 100 minutes.
- Recover condition: Discharge temperature (T7C1/2)  $\leq 90^{\circ}\text{C}$ .
- Reset method:
  - For P4 protection: Resume automatically.
  - For H6 protection: Manually restart.

### 2.22.4 Possible causes

- Outdoor unit stop valves are closed.
- Temperature sensor/switch not connected properly or has malfunctioned.
- Insufficient refrigerant.
- System blockage.
- Indoor load too large.
- System contains air or nitrogen.
- Poor condenser heat exchange.
- Main PCB damaged.

### 2.22.5 Procedure

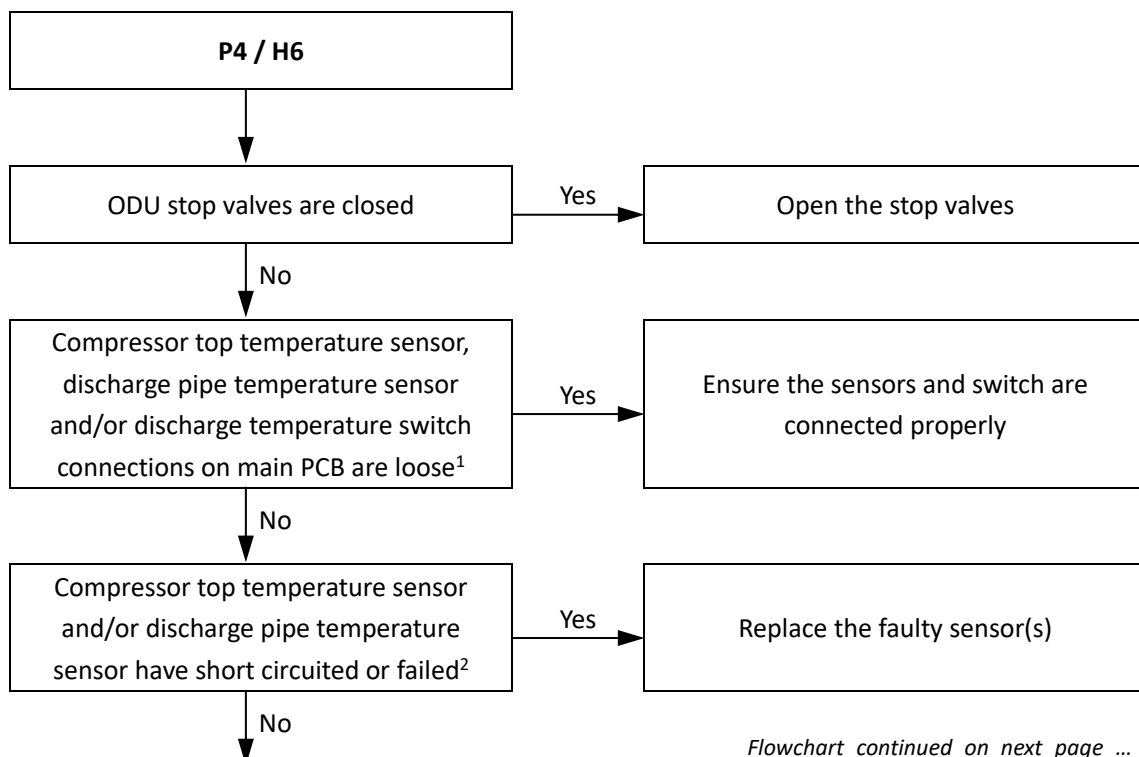

... flowchart continued from previous page

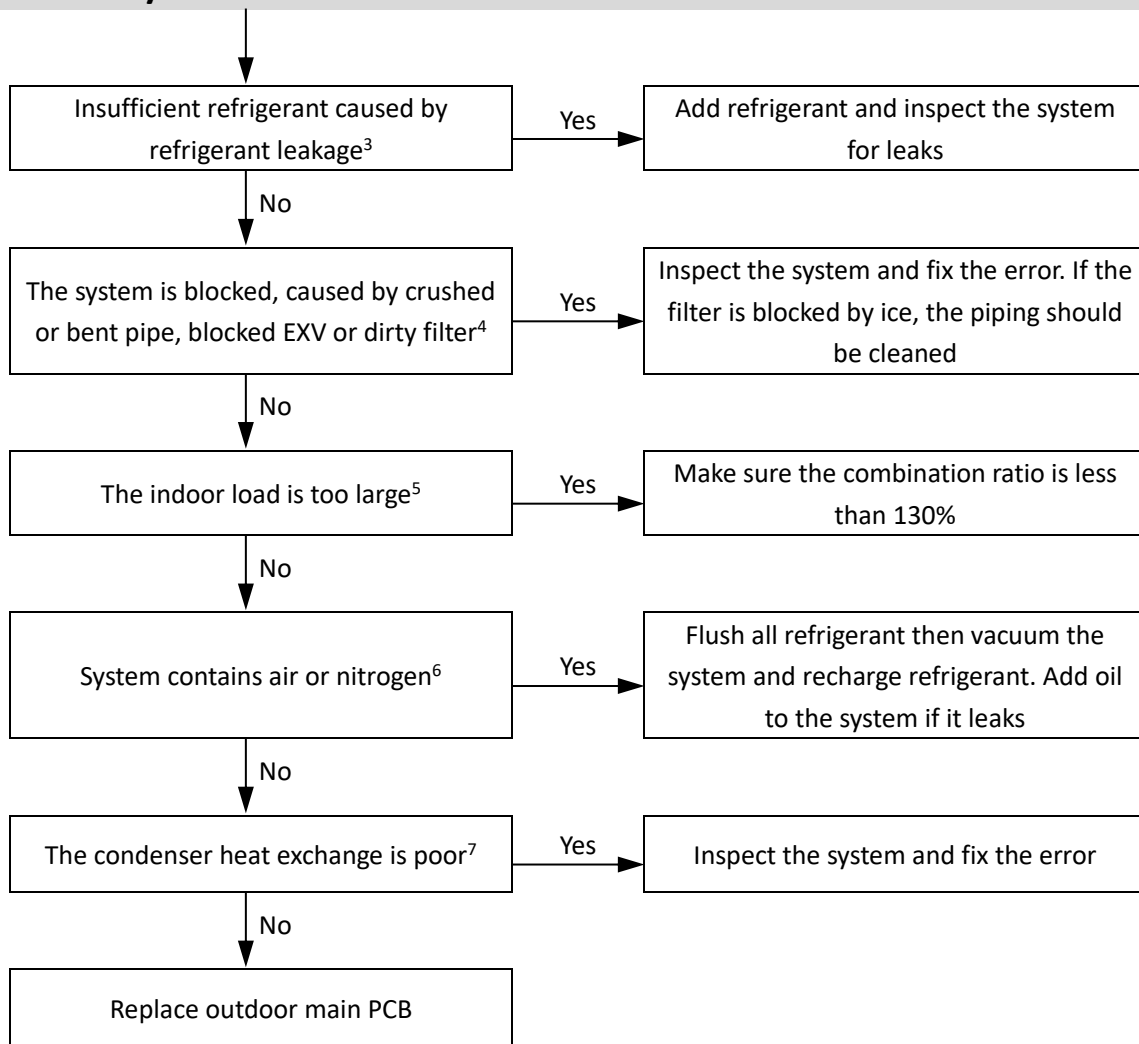

Notes:

1. Compressor top temperature sensor and discharge pipe temperature sensor connections are ports CN4 and CN5 on the main PCB (labeled 3 and 4, respectively, in Figure 5-2.1 in Part 5, 2.1 "Ports"). The discharge temperature switch connection is port CN19 on the main PCB (labeled 2 in Figure 5-2.1 in Part 5, 2.1 "Ports").
2. Measure sensor resistance. If the resistance is too low, the sensor has short-circuited. If the resistance is not consistent with the sensor's resistance characteristics table, the sensor has failed. Refer to Table 6-3.2 in Part 6, 3.1 "Temperature Sensor Resistance Characteristics".
3. An insufficiency of refrigerant causes compressor discharge temperature to be higher than normal, discharge and suction pressures to be lower than normal and compressor current to be lower than normal, and may cause frosting to occur on the suction pipe. These issues disappear once sufficient refrigerant has been charged into the system. For normal system parameters refer to Table 6-3.4 and 6-3.5 in Part 6, 3.2 "Normal Operating Parameters of Refrigerant System".
4. A low pressure side blockage causes compressor discharge temperature to be higher than normal, suction pressure to be lower than normal and compressor current to be lower than normal, and may cause frosting to occur on the suction pipe. For normal system parameters refer to Table 6-3.4 and 6-3.5 in Part 6, 3.2 "Normal Operating Parameters of Refrigerant System".
5. An indoor load that is too large causes suction and discharge temperatures to be higher than normal. For normal system parameters refer to Table 6-3.4 and 6-3.5 in Part 6, 3.2 "Normal Operating Parameters of Refrigerant System".
6. Air or nitrogen in the system causes discharge temperature to be higher than normal, discharge pressure to be higher than normal, compressor current to be higher than normal, abnormal compressor noise and an unsteady pressure meter reading. For normal system parameters refer to Table 6-3.4 and 6-3.5 in Part 6, 3.2 "Normal Operating Parameters of Refrigerant System".
7. In cooling mode check outdoor heat exchangers, fans and air outlets for dirt/blockages. In heating mode check indoor heat exchangers, fans and air outlets for dirt/blockages.

## 2.23 P5: Outdoor heat exchanger temperature protection

### 2.23.1 Digital display output

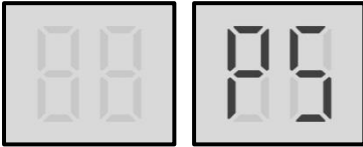

### 2.23.2 Description

- Outdoor heat exchanger temperature protection.
- All units stop running.
- Error code is only displayed on the unit with the error.

### 2.23.3 Trigger / recover condition

- Trigger condition: Outdoor heat exchanger temperature (T3)  $\geq 65^{\circ}\text{C}$ .
- Recover condition: Outdoor heat exchanger temperature (T3)  $< 55^{\circ}\text{C}$ .
- Reset method: Resume automatically.

### 2.23.4 Possible causes

- Outdoor unit stop valves are closed.
- Temperature sensor not connected properly or has malfunctioned.
- Indoor load too large.
- System contains air or nitrogen.
- Poor condenser heat exchange.
- High pressure side blockage.
- Main PCB damaged.

## 2.23.5 Procedure

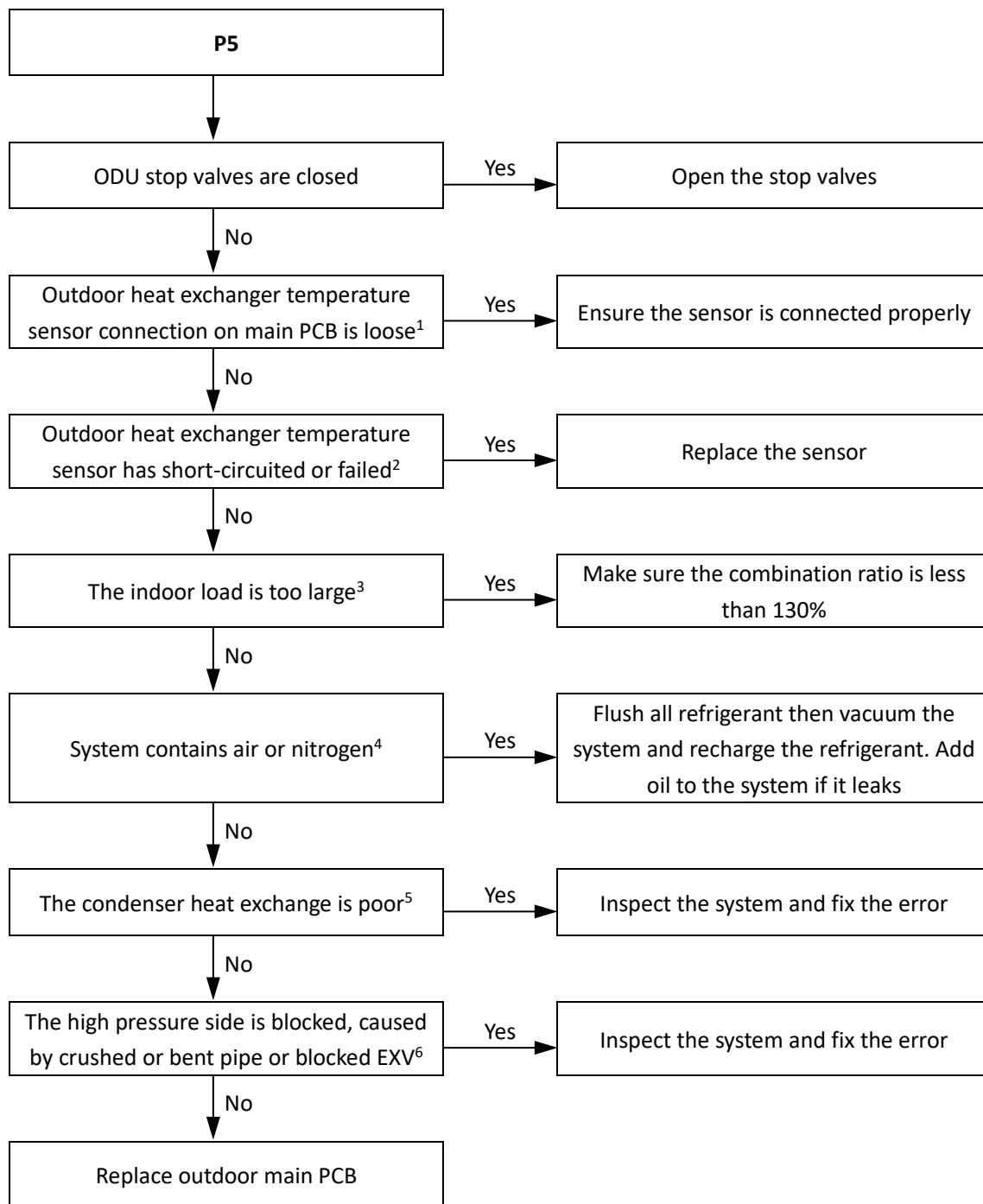

### Notes:

1. Outdoor heat exchanger temperature sensor connection is port CN1 on the main PCB (labeled 11 in Figure 5-2.1 in Part 5, 2.1 "Ports").
2. Measure sensor resistance. If the resistance is too low, the sensor has short-circuited. If the resistance is not consistent with the sensor's resistance characteristics table, the sensor has failed. Refer to Table 6-3.1 in Part 6, 3.1 "Temperature Sensor Resistance Characteristics".
3. An indoor load that is too large causes suction and discharge temperatures to be higher than normal. For normal system parameters refer to Table 6-3.4 and 6-3.5 in Part 6, 3.2 "Normal Operating Parameters of Refrigerant System".
4. Air or nitrogen in the system causes discharge temperature to be higher than normal, discharge pressure to be higher than normal, compressor current to be higher than normal, abnormal compressor noise and an unsteady pressure meter reading. For normal system parameters refer to Table 6-3.4 and 6-3.5 in Part 6, 3.2 "Normal Operating Parameters of Refrigerant System".
5. In cooling mode check outdoor heat exchangers, fans and air outlets for dirt/blockages. In heating mode check indoor heat exchangers, fans and air outlets for dirt/blockages.
6. High pressure side blockage causes discharge temperature to be higher than normal, discharge pressure to be higher than normal and suction pressure to be lower than normal. For normal system parameters refer to Table 6-3.4 and 6-3.5 in Part 6, 3.2 "Normal Operating Parameters of Refrigerant System".

## 2.24 P9, H9: Fan module protection

### 2.24.1 Digital display output

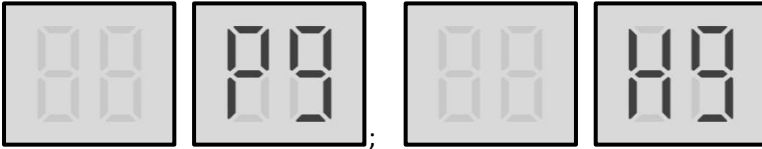

### 2.24.2 Description

- Fan module protection.
- All units stop running.
- Error code is only displayed on the unit with the error.

### 2.24.3 Trigger / recover condition

- Trigger condition:
  - For P9 protection: Fan speed is too low.
  - For H9 protection: P9 protection appears ten times in 120 minutes.
- Recover condition: Fan speed go back to normal.
- Reset method:
  - For P9 protection: Resume automatically; For H9 protection: Manually restart.

### 2.24.4 Possible causes

- Switch ENC2 incorrectly set.
- Power or communication wires not connected properly.
- Fan motor blocked or has failed.
- Power supply abnormal.
- AC filter board damaged.
- Fan module damaged.
- Main PCB damaged.

### 2.24.5 Procedure

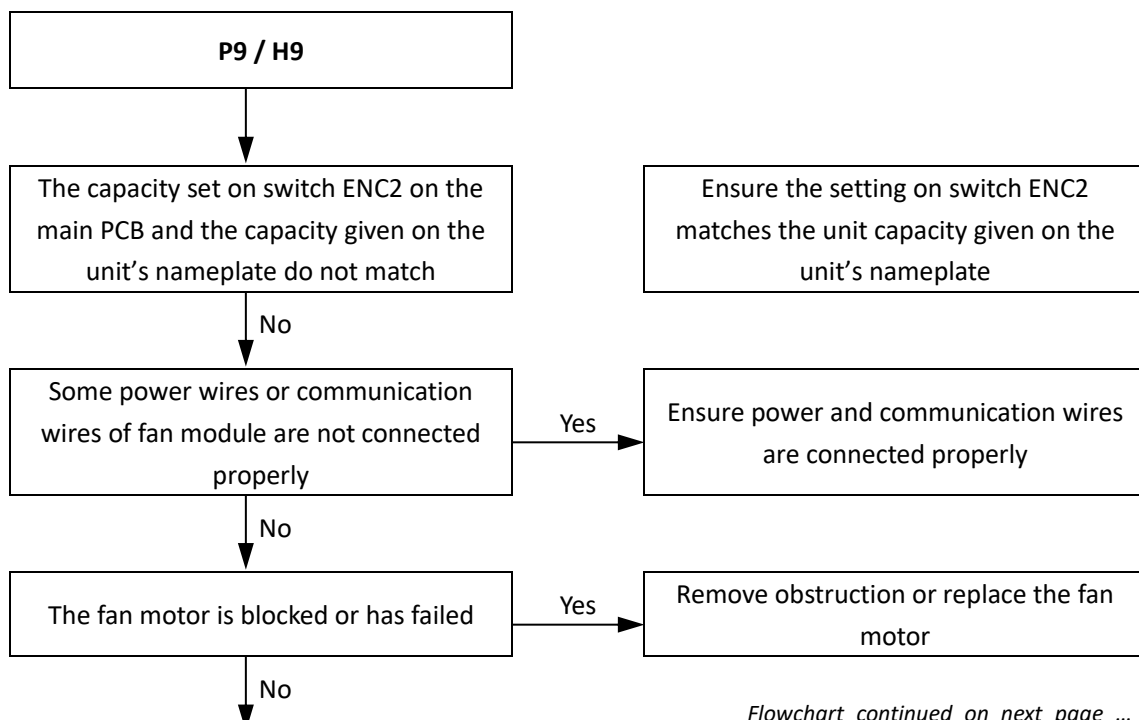

Flowchart continued on next page ...

... flowchart continued from previous page

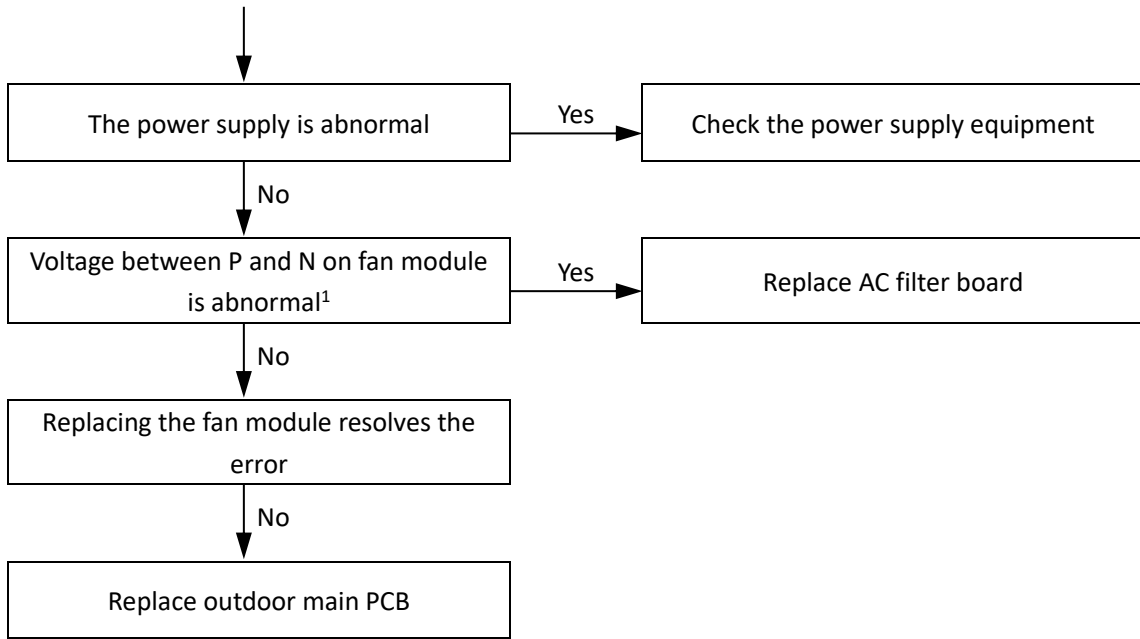

Notes:

1. The normal voltage between P and N on the fan module is 310V DC.

Figure 6-2.12: Fan module P N terminals

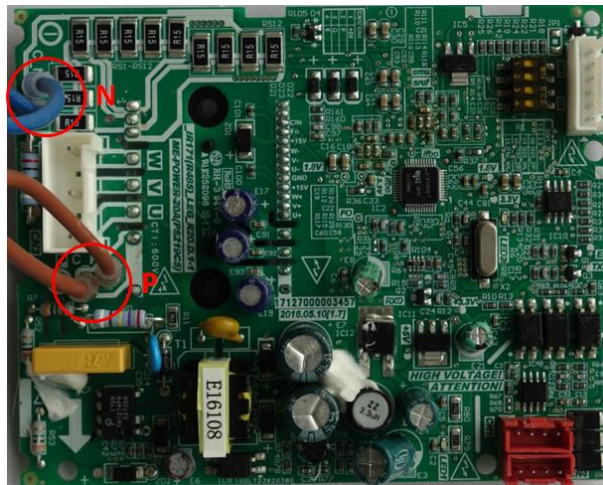

## 2.25 PL, C7: Inverter module temperature protection

### 2.25.1 Digital display output

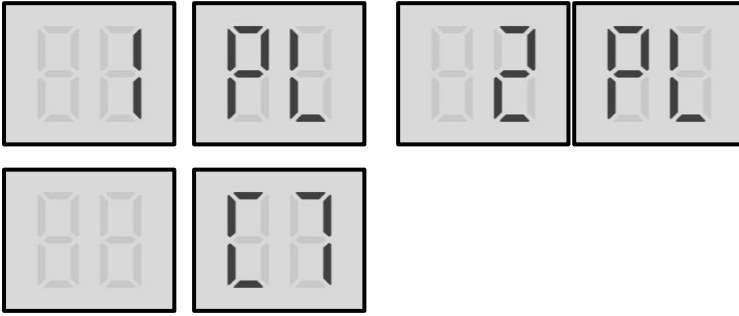

'x' is a placeholder for the compressor system (compressor and related electrical components), with 1 representing compressor system A and 2 representing compressor system B.

### 2.25.2 Description

- 1PL indicates inverter module A temperature protection.
- 2PL indicates inverter module B temperature protection.
- All units stop running.
- Error code is only displayed on the unit with the error.

### 2.25.3 Trigger / recover condition

- Trigger condition:
  - For PL protection: Inverter module heat sink temperature (TF1/2)  $\geq 80^{\circ}\text{C}$ .
  - For C7 protection: PL protection appears three times in 100 minutes.
- Recover condition: Inverter module heat sink temperature (TF1/2)  $< 65^{\circ}\text{C}$
- Reset method:
  - For PL protection: Resume automatically.
  - For C7 protection: Manually restart.

### 2.25.4 Possible causes

- Blocked, dirty or loose heat sink.
- Temperature sensor not connected properly or has malfunctioned.
- Main PCB damaged.



## 2.25.5 Procedure

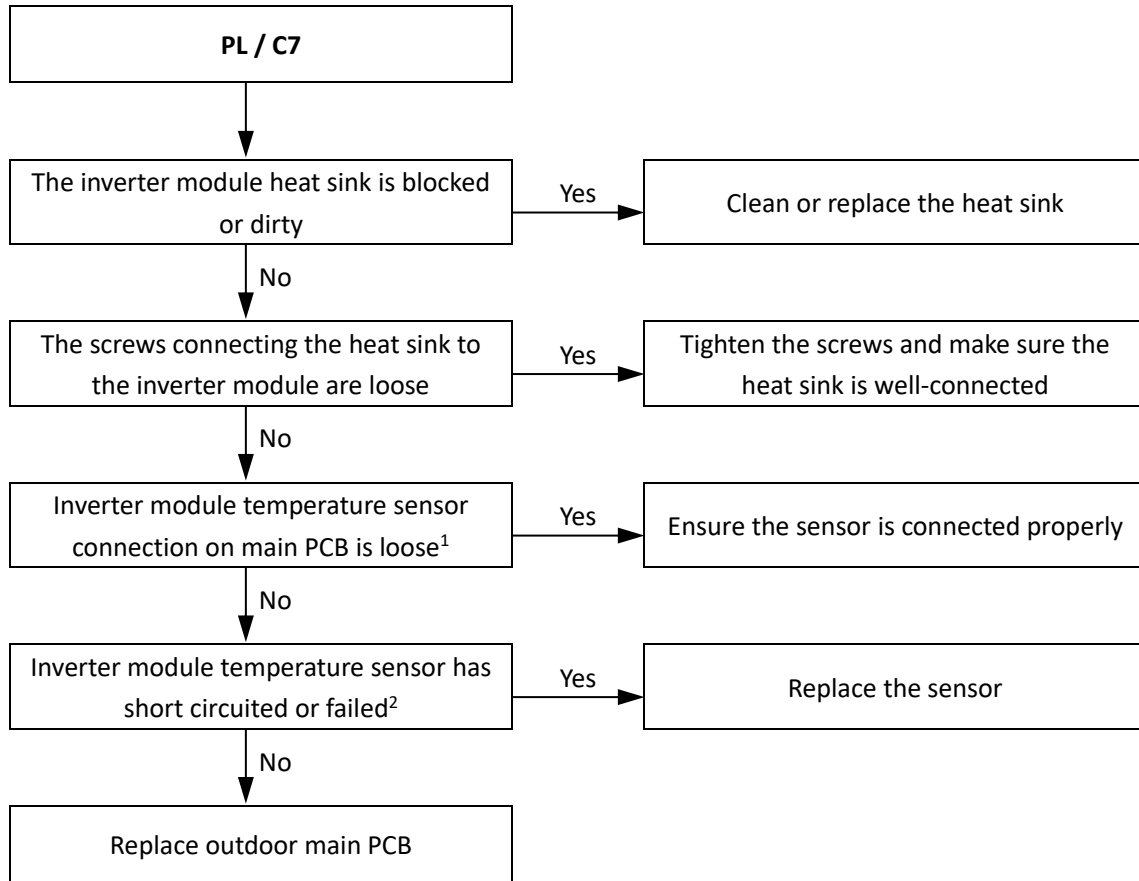

Notes:

1. Inverter module temperature sensor connection is port CN3 and CN3\_1 on the main PCB (labeled 5 and 6, respectively, in Figure 5-2.1 in Part 5, 2.1 "Ports").
2. Measure sensor resistance. If the resistance is too low, the sensor has short-circuited. If the resistance is not consistent with the sensor's resistance characteristics table, the sensor has failed. Refer to Table 6-3.3 in Part 6, 3.1 "Temperature Sensor Resistance Characteristics".

## 2.26 PP: Compressor discharge insufficient superheat protection

### 2.26.1 Digital display output

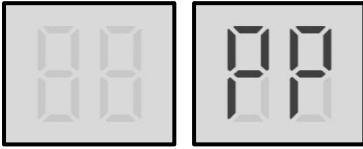

### 2.26.2 Description

- Compressor discharge insufficient superheat protection.
- All units stop running.
- Error code is only displayed on the unit with the error.

### 2.26.3 Trigger / recover condition

- Trigger condition: Discharge gas superheat is  $\leq 0^{\circ}\text{C}$  for 20 minutes or  $\leq 5^{\circ}\text{C}$  for 60 minutes.
- Recover condition: Discharge gas superheat go back to normal value.
- Reset method: Resume automatically.

### 2.26.4 Possible causes

- Temperature sensor not connected properly or has malfunctioned.
- Poor temperature sensor heat insulation.
- Excess refrigerant.
- Discharge pressure too high.
- Main PCB damaged.

## 2.26.5 Procedure

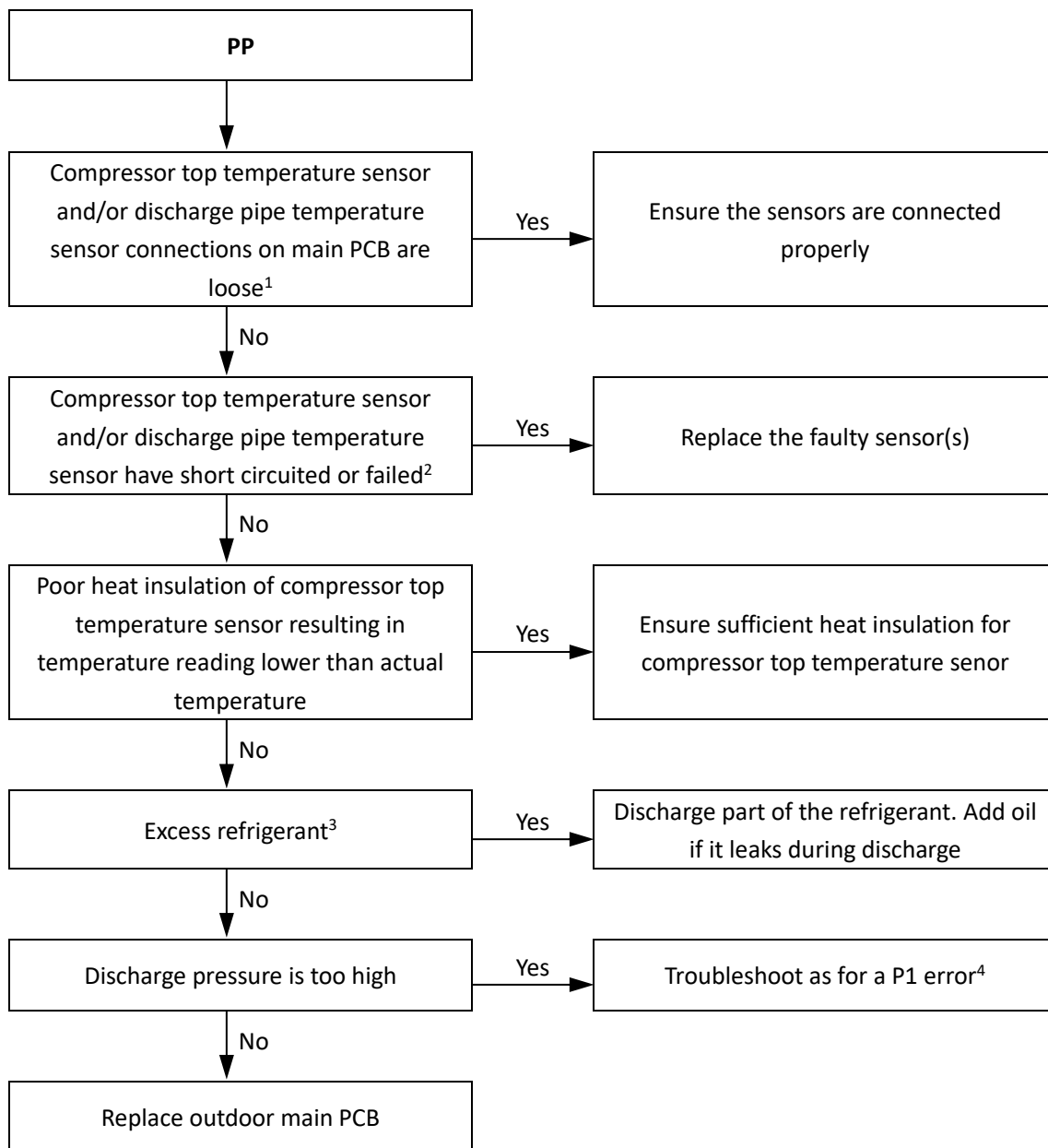

Notes:

1. Compressor top temperature sensor and discharge pipe temperature sensor connections are ports CN4 and CN5 on the main PCB (labeled 3 and 4, respectively, in Figure 5-2.1 in Part 5, 2.1 "Ports").
2. Measure sensor resistance. If the resistance is too low, the sensor has short-circuited. If the resistance is not consistent with the sensor's resistance characteristics table, the sensor has failed. Refer to Table 6-3.2 in Part 6, 3.1 "Temperature Sensor Resistance Characteristics".
3. Excess refrigerant causes discharge temperature to be lower than normal, discharge pressure to be higher than normal and suction pressure to be higher than normal. For normal system parameters refer to Table 6-3.4 and 6-3.5 in Part 6, 3.2 "Normal Operating Parameters of Refrigerant System".
4. See "P1 Troubleshooting".

### 3 Appendix to Part 6

#### 3.1 Temperature Sensor Resistance Characteristics

Table 6-3.1: Outdoor ambient temperature sensor and outdoor heat exchanger temperature sensor resistance characteristics

Temperature (°C)	Resistance (kΩ)	Temperature (°C)	Resistance (kΩ)	Temperature (°C)	Resistance (kΩ)	Temperature (°C)	Resistance (kΩ)
-20	115.3	20	12.64	60	2.358	100	0.6297
-19	108.1	21	12.06	61	2.272	101	0.6115
-18	101.5	22	11.50	62	2.191	102	0.5939
-17	96.34	23	10.97	63	2.112	103	0.5768
-16	89.59	24	10.47	64	2.037	104	0.5604
-15	84.22	25	10.00	65	1.965	105	0.5445
-14	79.31	26	9.551	66	1.896	106	0.5291
-13	74.54	27	9.124	67	1.830	107	0.5143
-12	70.17	28	8.720	68	1.766	108	0.4999
-11	66.09	29	8.336	69	1.705	109	0.4860
-10	62.28	30	7.971	70	1.647	110	0.4726
-9	58.71	31	7.624	71	1.591	111	0.4596
-8	56.37	32	7.295	72	1.537	112	0.4470
-7	52.24	33	6.981	73	1.485	113	0.4348
-6	49.32	34	6.684	74	1.435	114	0.4230
-5	46.57	35	6.400	75	1.387	115	0.4116
-4	44.00	36	6.131	76	1.341	116	0.4006
-3	41.59	37	5.874	77	1.291	117	0.3899
-2	39.82	38	5.630	78	1.254	118	0.3796
-1	37.20	39	5.397	79	1.2133	119	0.3695
0	35.20	40	5.175	80	1.174	120	0.3598
1	33.33	41	4.964	81	1.136	121	0.3504
2	31.56	42	4.763	82	1.100	122	0.3413
3	29.91	43	4.571	83	1.064	123	0.3325
4	28.35	44	4.387	84	1.031	124	0.3239
5	26.88	45	4.213	85	0.9982	125	0.3156
6	25.50	46	4.046	86	0.9668	126	0.3075
7	24.19	47	3.887	87	0.9366	127	0.2997
8	22.57	48	3.735	88	0.9075	128	0.2922
9	21.81	49	3.590	89	0.8795	129	0.2848
10	20.72	50	3.451	90	0.8525	130	0.2777
11	19.69	51	3.318	91	0.8264	131	0.2708
12	18.72	52	3.192	92	0.8013	132	0.2641
13	17.80	53	3.071	93	0.7771	133	0.2576
14	16.93	54	2.959	94	0.7537	134	0.2513
15	16.12	55	2.844	95	0.7312	135	0.2451
16	15.34	56	2.738	96	0.7094	136	0.2392
17	14.62	57	2.637	97	0.6884	137	0.2334
18	13.92	58	2.540	98	0.6682	138	0.2278
19	13.26	59	2.447	99	0.6486	139	0.2223

Table 6-3.2: Compressor top temperature sensor and discharge pipe temperature sensor resistance characteristics

Temperature (°C)	Resistance (kΩ)	Temperature (°C)	Resistance (kΩ)	Temperature (°C)	Resistance (kΩ)	Temperature (°C)	Resistance (kΩ)
-20	542.7	20	68.66	60	13.59	100	3.702
-19	511.9	21	65.62	61	13.11	101	3.595
-18	483.0	22	62.73	62	12.65	102	3.492
-17	455.9	23	59.98	63	12.21	103	3.392
-16	430.5	24	57.37	64	11.79	104	3.296
-15	406.7	25	54.89	65	11.38	105	3.203
-14	384.3	26	52.53	66	10.99	106	3.113
-13	363.3	27	50.28	67	10.61	107	3.025
-12	343.6	28	48.14	68	10.25	108	2.941
-11	325.1	29	46.11	69	9.902	109	2.860
-10	307.7	30	44.17	70	9.569	110	2.781
-9	291.3	31	42.33	71	9.248	111	2.704
-8	275.9	32	40.57	72	8.940	112	2.630
-7	261.4	33	38.89	73	8.643	113	2.559
-6	247.8	34	37.30	74	8.358	114	2.489
-5	234.9	35	35.78	75	8.084	115	2.422
-4	222.8	36	34.32	76	7.820	116	2.357
-3	211.4	37	32.94	77	7.566	117	2.294
-2	200.7	38	31.62	78	7.321	118	2.233
-1	190.5	39	30.36	79	7.086	119	2.174
0	180.9	40	29.15	80	6.859	120	2.117
1	171.9	41	28.00	81	6.641	121	2.061
2	163.3	42	26.90	82	6.430	122	2.007
3	155.2	43	25.86	83	6.228	123	1.955
4	147.6	44	24.85	84	6.033	124	1.905
5	140.4	45	23.89	85	5.844	125	1.856
6	133.5	46	22.89	86	5.663	126	1.808
7	127.1	47	22.10	87	5.488	127	1.762
8	121.0	48	21.26	88	5.320	128	1.717
9	115.2	49	20.46	89	5.157	129	1.674
10	109.8	50	19.69	90	5.000	130	1.632
11	104.6	51	18.96	91	4.849		
12	99.69	52	18.26	92	4.703		
13	95.05	53	17.58	93	4.562		
14	90.66	54	16.94	94	4.426		
15	86.49	55	16.32	95	4.294		
16	82.54	56	15.73	96	4.167		
17	78.79	57	15.16	97	4.045		
18	75.24	58	14.62	98	3.927		
19	71.86	59	14.09	99	3.812		

Table 6-3.3: Inverter module temperature sensor resistance characteristics

Temperature (°C)	Resistance (kΩ)	Temperature (°C)	Resistance (kΩ)	Temperature (°C)	Resistance (kΩ)	Temperature (°C)	Resistance (kΩ)
-30	971.4	10	109.0	50	19.70	90	5.000
-29	912.8	11	103.9	51	18.97	91	4.855
-28	858.2	12	99.02	52	18.26	92	4.705
-27	807.3	13	94.44	53	17.59	93	4.566
-26	759.7	14	90.11	54	16.94	94	4.431
-25	715.3	15	86.00	55	16.32	95	4.301
-24	673.6	16	82.09	56	15.73	96	4.176
-23	634.7	17	78.38	57	15.16	97	4.055
-22	598.2	18	74.87	58	14.62	98	3.938
-21	564.1	19	71.53	59	14.10	99	3.825
-20	532.2	20	68.36	60	13.60	100	3.716
-19	502.2	21	65.34	61	13.12	101	3.613
-18	474.1	22	62.47	62	12.65	102	3.514
-17	447.7	23	59.75	63	12.22	103	3.418
-16	423.0	24	57.17	64	11.79	104	3.326
-15	399.8	25	54.71	65	11.39	105	3.235
-14	378.0	26	52.36	66	10.99	106	3.148
-13	357.5	27	50.13	67	10.62	107	3.063
-12	338.2	28	48.01	68	10.25	108	2.982
-11	320.1	29	45.99	69	9.909	109	2.902
-10	303.1	30	44.07	70	9.576	110	2.826
-9	287.1	31	42.23	71	9.253	111	2.747
-8	272.0	32	40.48	72	8.947	112	2.672
-7	257.8	33	38.81	73	8.646	113	2.599
-6	244.4	34	37.23	74	8.362	114	2.528
-5	231.9	35	35.71	75	8.089	115	2.460
-4	220.0	36	34.27	76	7.821	116	2.390
-3	208.7	37	32.89	77	7.569	117	2.322
-2	198.2	38	31.58	78	7.323	118	2.256
-1	188.2	39	30.33	79	7.088	119	2.193
0	178.8	40	29.13	80	6.858	120	2.132
1	169.9	41	27.98	81	6.640	121	2.073
2	161.5	42	26.89	82	6.432	122	2.017
3	153.6	43	25.85	83	6.230	123	1.962
4	146.1	44	24.85	84	6.033	124	1.910
5	139.1	45	23.90	85	5.847	125	1.859
6	132.3	46	22.98	86	5.667		
7	126.0	47	22.10	87	5.492		
8	120.0	48	21.26	88	5.322		
9	114.3	49	20.47	89	5.159		

## 3.2 Normal Operating Parameters of Refrigerant System

Under the following conditions, the operating parameters given in Tables 5-5.4 and 5-5.5 should be observed:

- The master outdoor unit can detect all the indoor units.
- The number of indoor units displayed on DSP2 is steady and is equal to the actual number of indoor units installed.
- All stop valves are open and all indoor unit EXVs are connected to their unit's PCB.
- If the combination ratio is 100% or less, all the indoor units are currently running and if the combination ratio is more than 100%, indoor units with total capacity equal to the total capacity of the outdoor units are currently running.
- If the outdoor ambient temperature is high, the system is being run in cooling mode with the following settings: temperature 17°C; fan speed high.
- If the outdoor ambient temperature is low, the system is being run in heating mode with the following settings: temperature 30°C; fan speed high.
- The system has been running normally for more than 30 minutes.

*Table 6-3.4: Outdoor unit cooling mode operating parameters*

<b>Outdoor ambient temperature</b>	<b>°C</b>	< 10	10 to 26	26 to 31	31 to 41	> 41
<b>Average discharge temperature</b>	<b>°C</b>	60-76	62-78	65-82	67-92	69-92
<b>Average discharge superheat</b>	<b>°C</b>	17-30	17-33	17-34	17-36	10-32
<b>Discharge pressure</b>	<b>MPa</b>	2.3-2.8	2.3-2.8	2.4-3.6	2.6-3.8	3.1-4.2
<b>Suction pressure</b>	<b>MPa</b>	0.6-0.7	0.7-0.9	0.8-1.0	1.0-1.2	1.2-1.4
<b>DC inverter compressor current</b>	<b>A</b>	9-20	11-22	12-25	15-29	20-26

*Table 6-3.5: Outdoor unit heating mode operating parameters*

<b>Outdoor ambient temperature</b>	<b>°C</b>	< -10	-10 to 0	0 to 5	5 to 10	10 to 17	> 17
<b>Average discharge temperature</b>	<b>°C</b>	56-74	57-76	58-78	61-82	63-82	63-82
<b>Average discharge superheat</b>	<b>°C</b>	17-35	17-35	17-35	17-33	14-33	14-33
<b>Discharge pressure</b>	<b>MPa</b>	1.7-2.4	1.8-2.5	1.9-3.0	2.2-3.2	2.3-3.2	2.3-3.2
<b>Suction pressure</b>	<b>MPa</b>	1.4-1.6	1.5-1.7	1.6-2.2	1.8-2.6	1.8-2.6	2.0-2.4
<b>DC inverter compressor current</b>	<b>A</b>	11-25	13-27	12-28	11-28	11-25	15-20